



WILDLIFE AND ASSET PROTECTION PRODUCTS

SELECTION GUIDE

Table of contents

I Bus Insulation & Clearance Reduction



BBIT BPTM Busbar Insulating Tubing (5 - 36 kV).....	6
HVBT High Voltage Busbar Insulating Tape (5 - 15 kV).....	7
HVIS High Voltage Insulating Sheet (5 - 17,5 kV).....	8
BMOD Modular Busbar Insulating Covers (5 - 36 kV).....	9
Busbar Insulation Technical Data Clearance Reduction Table.....	10

Section 1

II Substation



BISG BISG-24 Bus Isolation Squirrel Guard.....	14
BCAC Bushing Connection Animal Covers.....	15
BCAC-IC Bushing Connection Inspection Substation Covers.....	16
BCIC Bushing Connection Insulating Covers.....	17
MVFT Medium Voltage Fusion Tape.....	23
MVCC Medium Voltage Conductor Covers.....	24

Section 2

III Overhead



MVLC Medium Voltage Line Cover.....	28
BCIC Birdcap Protection Covers.....	30
BCIC Dead End and Suspension Clamp Covers.....	32
BCAC BCIC Distribution Covers for Animal Protection.....	33
AFD Avian Flight Diverters.....	34

Section 3

IV Low Voltage



LVIT Tube Low Voltage Insulating Tubing (0 - 1 kV).....	38
LV BMOD Modular Busbar Insulation Connection Covers (0 - 1 kV).....	39
LVIC Low Voltage Insulation Covers (0 - 1 kV).....	40
LVBC Low Voltage Bushing Covers (0 - 1 kV).....	42

Section 4

V Contamination/ Flashover Prevention

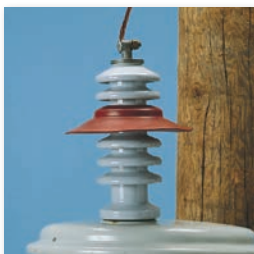

HVCE High Voltage Creepage Extenders.....	46
HVCE WA Wraparound High Voltage Creepage Extenders.....	47
HVBS High Voltage Booster Shed.....	48
RRGS Guano Shield.....	49

Section 5

VI Applications and Technical Specifications



Protection, Repair and Maintenance.....	52
Protection of Outdoor Equipment.....	53
Protection for Medium-Voltage Products.....	55

Section 6





Section I Bus Insulation & Clearance Reduction

BBIT BPTM	
Busbar Insulating Tubing (5 - 36 kV).....	6
HVBT	
High Voltage Busbar Insulating Tape (5 - 15 kV).....	7
HVIS	
High Voltage Insulating Sheet (5 - 17,5 kV).....	8
BMOD	
High Voltage Insulating Covers (5 - 36 kV).....	9
Busbar Insulation Technical Data	
Clearance Reduction Table.....	10

BBIT/BPTM

Busbar Insulating Tubing (5 - 36 kV)*



BBIT (5 - 36 kV)

Heavy-wall tubing for use on straight or bent bars where maximum clearance reduction or 36 kV insulation is required.

BPTM (5 - 24 kV)

Medium-wall tubing for use on straight or bent bars where some clearance reduction or 24 kV insulation is required. These heat-shrinkable tubes for straight and bent busbars are extremely flexible, allowing them to be easily positioned on busbars and quickly installed using a gas torch or oven. They have a high expansion ratio, so each size of tubing fits a range of busbar sizes. Both BBIT and BPTM tubing are ideal for original equipment assembly, and for retrofit applications where access to one end is available.

BBIT and BPTM tubings are also ideal for protection against accidental bridging caused by birds and animals. They are suitable for indoor and outdoor applications.

Product selection

BBIT should normally be used on the following busbar sizes



Product size	Rectangular bars L + T (mm)		Round bars D (mm)	
	min	max	min	max
BBIT 25/10	17	28	11	20
BBIT 40/16	28	45	18	32
BBIT 65/25	44	69	28	47
BBIT 100/40	69	102	44	72
BBIT 150/60	102	148	65	105
BBIT 175/80	133	196	85	125

Ordering information

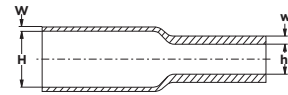

Ordering description	Inside diameter (mm)		Wall thickness (mm)		UOM : roll of length (m)
	H min	h max	W nom	w min	
BBIT 25/10-A/U-4	25	10	1,6	3,6	25
BBIT 40/16-A/U-4	40	16	1,6	3,6	20
BBIT 65/25-A/U-4	65	25	1,6	3,6	15
BBIT 100/40-A/U-4	100	40	1,6	3,6	15
BBIT 150/60-A/U-4	150	60	1,6	3,6	15
BBIT 175/80-A/U-4	175	80	1,6	3,6	10

NOTE W, H = as supplied w, h = after free recovery. Maximum longitudinal change after free recovery: ±5%. Maximum eccentricity: 35% (as supplied), 15% (after free recovery). Fit the larger size of BBIT if two sizes fit the required application.

Product selection

BBIT should normally be used on the following busbar sizes



Product size	Rectangular bars L + T (mm)		Round bars D (mm)	
	min	max	min	max
BPTM 15/6	12	18	6,5	12
BPTM 30/12	22	38	13,5	25
BPTM 50/20	36	65	22	43
BPTM 75/30	55	95	33	63
BPTM 100/40	70	130	44	86
BPTM 120/50	90	165	55	105
BPTM 175/70	125	235	80	150
BPTM 205/110	200	276	127	190
BPTM 235/130	235	315	150	220

Ordering information

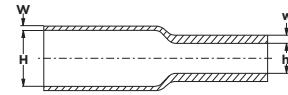

Ordering description	Inside diameter (mm)		Wall thickness (mm)		UOM : roll of length (m)
	H min	h max	W nom	w min	
BPTM 15/6-A/U-4	15	6	1,1	1,90	30
BPTM 30/12-A/U-4	30	12	1,1	2,20	30
BPTM 50/20-A/U-4	50	20	1,1	2,35	30
BPTM 75/30-A/U-4	75	30	1,1	2,35	20
BPTM 100/40-A/U-4	100	40	1,1	2,35	25
BPTM 120/50-A/U-4	120	50	1,3	2,80	25
BPTM 175/70-A/U-4	175	70	1,3	2,80	15
BPTM 205/110-A/U-4	205	110	1,3	2,80	10
BPTM 235/130-A/U-4	235	130	1,5	3,10	20

NOTE W, H = as supplied w, h = after free recovery. Maximum longitudinal change after free recovery: ±5% -10%. Maximum eccentricity: 40% (as supplied), 15% (after free recovery). ≤ 75/30 10% ≥ 100/40 15%. Fit the larger size of BBIT if two sizes fit the required application.

Ordering/Application Information

- Select the appropriate catalogue number. Confirm selection with bus dimensions.
- *2. These products may be suitable for applications with higher voltages than those listed. Please contact your TE Connectivity representative for more information.
- Bolted connections require two layers of tubing or a fiber bolt pad.
- To environmentally seal the bus at each end of the BBIT tubing, order S-1085 sealant strip separately.
- To environmentally seal the busbar at each end of the tubing, use S1085 sealing mastic.
- Minimum continuous length is 4,5 meters.

HVBT

High Voltage Busbar Insulating Tape (5 – 15 kV)*



HVBT tape is an adhesive coated, high-voltage, heat-shrinkable, general-purpose tape for insulating straight and bent bars in retrofit applications where tubing cannot be used. In addition, HVBT easily insulates unusual connections and geometries in the factory or field.

HVBT tape is also ideal for protection against incidental/accidental bridging caused by birds and animals. HVBT may be suitable for higher voltage applications (see Ordering information #2 below). The HVBT adhesive layer fuses the tape layers but does not stick to bus or hardware, thus providing environmental sealing while allowing fast, easy removal.

HVBT tape may be used in applications up to 15 kV in accordance with ANSI/IEEE specifications and up to 36 kV in accordance with IEC specifications.

Rated to ANSI/IEEE C37.20-1987.

Selection Information: dimensions in millimeters/meters

Bus Width		Recommended Product	HVBT length needed per Meter of busbar
 RECTANGULAR BUSBAR	25	HVBT-12-A (B20)	10,0
	50	HVBT-14-A (B10)	7,6
	75	HVBT-14-A (B10)	11,4
	100	HVBT-14-A (B10)	15,6
	150	HVBT-14-A (B10)	25,0
	200	HVBT-16-A (B10)	15,6

 SQUARE BUSBAR	25 x 25	HVBT-14-A (B10)	6,0
	50 x 50	HVBT-14-A (B10)	12,5
	75 x 75	HVBT-14-A (B10)	20,0
	100 x 100	HVBT-16-A (B10)	12,5
	150 x 150	HVBT-16-A (B10)	20,0

 ROUND BUSBAR	12	HVBT-12-A (B20)	5,0
	25	HVBT-14-A (B10)	5,0
	50	HVBT-14-A (B10)	10,0
	75	HVBT-14-A (B10)	16,7
	100	HVBT-16-A (B10)	10,0

Ordering/Application Information

1. Select the appropriate catalogue number for the application. Confirm selection with the following recommendations and HVBT tape dimensions:

HVBT-12-A is best for short lengths and small bus sizes.
HVBT-14-A is the most versatile width for general purpose use.
HVBT-16-A is useful for long lengths and larger bus sizes.

HVBT tape dimensions:

Catalogue Number	Roll Width	Roll Length
HVBT-12-A (B20)	25 mm	10 M
HVBT-14-A (B10)	50 mm	10 M
HVBT-16-A (B10)	100 mm	10 M

*2. HVBT may be suitable for applications with higher voltage than those listed. Please contact your TE Connectivity representative for more information.

3. To environmentally seal the bus, order S-1085 sealant strips separately.

4. Recommended application is to wrap the tape around the busbar using a two-thirds overlap.

5. Bolted connections require two layers of tape.

6. Standard package:

HVBT-12-A (B20): 2 rolls/box
HVBT-14-A (B10): 1 roll/box
HVBT-16-A (B10): 1 roll/box

7. Continuous operating temperature: 90°C

8. Related test reports: EDR-5466, EDR-5422

HVIS

High Voltage Busbar Insulating Sheet (5 - 17,5 kV)



HVIS is an adhesive coated, heat-shrinkable sheet that shrinks in two directions to tightly conform to complex shapes. It is ideal for insulating busbar tees, elbows, and other connections where tubing or tape cannot be used. HVIS may also be used in conjunction with Raysulate electrical insulating tapes and tubings or alone to help protect against accidental bridging caused by birds and animals.

Selection Information: dimensions in millimeters/meters

Catalogue Number	Width	Length	Packaging
HVIS-05-(B3) NS	660	500	Sheet
HVIS-10-(B1) NS	660	10 m	Roll

Selection Information: dimensions in millimeters

Bus Width (mm)	Cut Size Needed	Number of Installations HVIS-05 Sheet	Per Sheet/Roll HVIS-10 Roll
 T CONNECTION	25	275 x 225	4
	50	325 x 250	4
	75	400 x 275	2
	100	450 x 325	2
	150	550 x 425	1
 ELBOW CONNECTION	25	275 x 175	4
	50	325 x 225	4
	75	375 x 250	2
	100	450 x 275	2
	150	550 x 325	1

HVIS-Installation tools

Set of installation tools for insulation enhancement products (HVIS, SMOE)	
HVIS-TOOLS-01	spring clamps (12x), flat-steel bar 350 x 20 mm (2x), right angle steel bars 120 x 120 mm (8x)
HVIS-TOOLS-02	spring clamps (24x), flat-steel bars 350 x 20 mm (2x), right angle steel bars 120 x 120 mm and 160 x 160 mm (8 each), turning pair steel bars 200 x 40 mm (1x), vice-grap wrench (1x), hose clamps Ø 125 and Ø 160 mm (2 each)

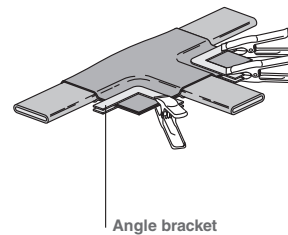
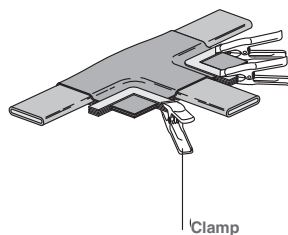
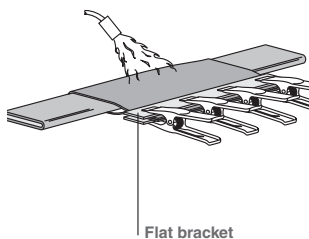

Ordering/Application Information

- Select the appropriate catalogue number. Confirm selection with dimensions.
- Busbars should be insulated as close as possible to the bolted joint. Cut size should extend a minimum of 100 mm onto each leg of the joint before shrinking.
- The above table should be used as a guide only; experiment to confirm final cut size. Table is based on 15 mm bus thickness.
- To environmentally seal each leg of the bus, order S-1085 sealant strips separately.
- HVIS may be rated for applications up to 36 kV. Please contact your TE Connectivity representative for more information.
- Standard package:
HVIS-05: 3 sheets/box
HVIS-10: 1 roll/box
- Related test report: EDR-5175

BMOD

Busbar Insulation Connection Covers

Raychem cold applied busbar insulation covers Voltage Class 36 kV, Application range 50 mm (2”), 75 mm (3”) and 100 mm (4”).



PRODUCT DESCRIPTION

- The BMOD family of busbar covers are designed to protect and insulate energised busbars from flashover due to accidental contact and are useful in confined spaces.
- They can be used on bare busbars, switchgear connections, substations and other electrical equipment.
- Cold applied half-shells are fixed with easy push fit latches for retro-fit installation.
- Compatible with all other TE and Raychem heatshrink tubes and tapes.

APPLICATIONS

- Allows equipment designers to reduce air spacings between busbars when used in conjunction with TE and Raychem heatshrink tube or tape.
- Provides flashover protection up to 36 kV on the Medium Voltage systems, Red covers.
- “Tee”, “Elbow” and “Straight” connection. 1 x 1 busbar combinations.
- Maximum bar thickness 12 mm (1/2”).
- Pack size 12.

FEATURE AND BENEFITS

- Made from Raychem BCIS Sheet.
- Suitable for indoor and outdoor use.
- Excellent anti-tracking performance.
- Operating temp rating up to +105°C.
- Compatible with BBIT, BPTM and HVBT.
- Excellent U.V. performance.

Raychem BMOD Insulation Covers

Part Number Description		
HV	Medium Voltage system	36 kV
050 075 100	Busbar size x 12 mm Max	50 mm 75 mm 100 mm
T L S	Connection shape	Tee Elbow Straight
11	1x1 Busbar Combination	
00 01 02	Hand arrangement Only Right and Left	Straight Right Hand Left Hand
(B12)	Pack size	12

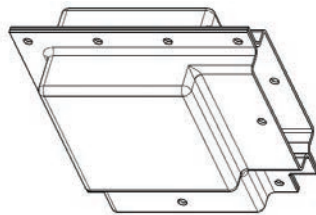
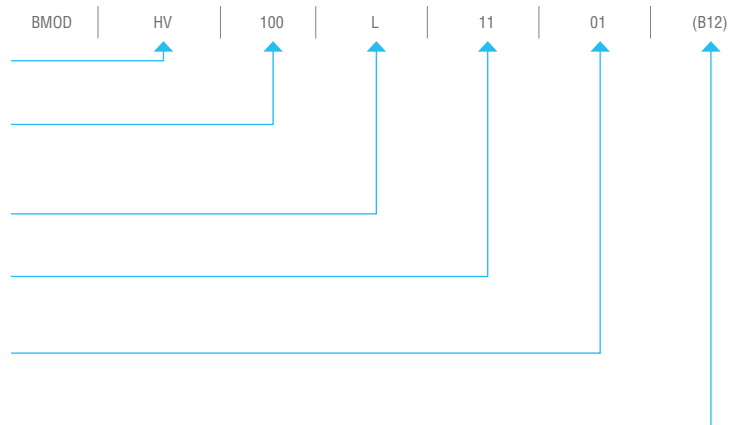

BMOD-HV-100-L11-01 (B12)

BMOD Cover for HV, 100 mm x 12 mm single busbar, “L” Right Hand Angle, pack of 12

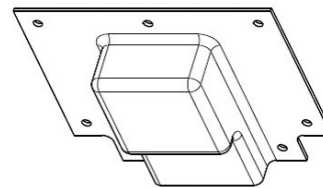

BMOD-HV-050-T11-00 (B12)

BMOD Cover for HV, 50 mm x 12 mm single busbar, “Tee” Shape, pack of 12

Busbar Insulation Technical Data

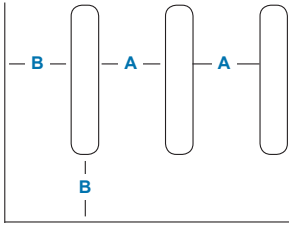

This table indicates clearance differences for rectangular busbars without and with various Raysulate electrical insulation products. These spacings are derived from BIL, AC-withstand, DC-withstand, and discharge-extinction tests on a limited number of busbar configurations insulated with Raysulate electrical insulation products.

Due to the wide range of possible busbar geometries, these spacings should not be adopted without actual testing by the user. Sharp electrodes and unusual geometries will require wider spacings. Always consider the smallest gap is likely to be at bolted connection positions.

NOTE Phase-to-phase distances are reduced more than phase-to-ground distances because it is assumed that each phase is insulated.

Selection Information: dimensions in millimeters

System Voltage kV	BIL kV	Uninsulated Clearance (Indoor)		BBIT Clearance (Indoor)		BPTM, HVBT, and HVIS Clearance (Indoor)	
		A*	B**	A*	B**	A*	B**
15	95	190	125	55	65	85	105
25	125	265	190	70	100	115	150
35	150	320	240	140	190	165	200

* Phase-to-phase

** Phase-to-ground

Recommended Guide Specification

Please feel free to use the following in your design specification:

Insulation for energized bus components and connections shall consist of tubing, tape, and sheets that are factory-engineered to meet applicable switch gear performance requirements.

All insulation components shall be fabricated from flexible, crosslinked, heat-shrinkable polymeric materials formulated to provide high dielectric strength, adequate thermal endurance at bus operating temperatures, and tracking and erosion resistance.

The insulation materials shall contain no halogen compounds and be compatible with other commercial, factory-installed bus insulation materials. Materials shall be installable at temperatures as low as -40°C . Adhesive coatings on tape and sheet products shall not adhere to metal surfaces, thus permitting easy re-entry to the connections.

The insulation supplier shall furnish technical data to document design and performance to these requirements and functional testing of the complete insulation system in accordance with ANSI/IEEE C37.20.



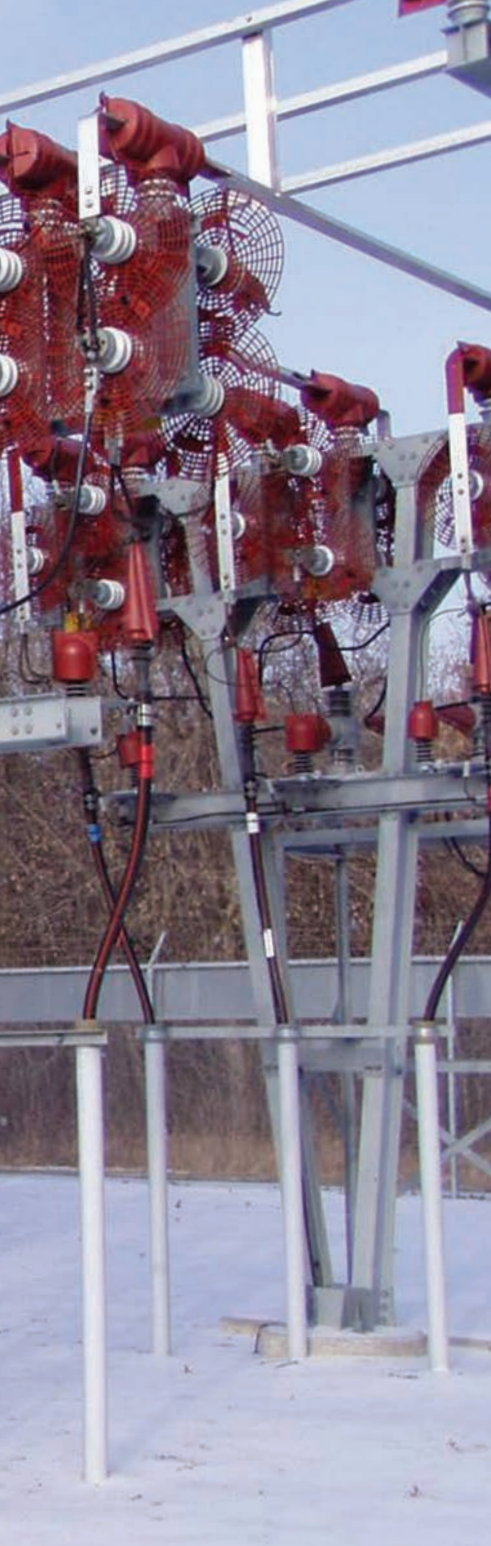

Section II Substation

BISG BISG-24	
Bus Isolation Squirrel Guard	14
BCAC	
Bushing Connection Animal Covers	15
BCAC-IC	
Bushing Connection Inspection Substation Covers	16
BCIC	
Bus Connection Insulating Cover.....	17
MVFT	
Medium Voltage Fusion Tape (0 - 15 kV).....	23
MVCC	
Medium Voltage Conductor Cover (0 - 25 kV)	24

BISG | BISG-24

Bus Isolation Squirrel Guard



BISG-60/115-02
installed on switch

This isolation guard prevents animal-caused outages in electrical sub-station equipment.

RELIABLE OUTAGE PREVENTION

BISG discs have been successfully eliminating outages caused by squirrels, raccoons, opossums, cats, and other animals in substations for years. The guards are designed to allow for excellent visibility of switch blades and other components through the guard while providing mechanical resistance to power arcs and high winds.

HIGH PERFORMANCE MATERIAL

Superior high voltage outdoor materials are used in the BISG guard design. The rugged, track resistant, UV-stable polymer ensures long-term performance even in the most extreme environmental conditions.

FASTER, EASIER INSTALLATION

The BISG-24 guard can be installed on energized equipment by one person. The new design incorporates a wedge device which makes hot-stick installations on vertical and horizontal mounted insulators quick and easy.



BISG-24 energized install

EXPANDED SIZE RANGE

The BISG guard family fits insulator core diameters ranging from 25 mm to 125 mm from the factory. The "grill" type design allows easy field modifications for even larger diameters (see your local TE representative for details).

The BISG guard can also have its outside diameter reduced by trimming along the grill ribs. This will allow the guard to fit in tight phase-to-phase insulator applications.



BISG-60/115-02
installed on bus
support insulator

Selection Information: dimensions in millimeters

BISG Catalogue Number	Insulator Core Diameter Range	Overall Product Diameter	Color	Installation
BISG-60/115-02 (B10)	25 - 115	610	Red	De-energized
BISG-60/115-03-HOT (B10)	25 - 115	610	Red	Two stick (energized)

BISG-24 Catalogue Number	Insulator Core Diameter Range	Overall Product Diameter*	Color	Installation
BISG-24-01 (B10)	62 - 125	610	Red	One stick (energized)

* Overall product diameter can be trimmed down to 410 mm diameter

Ordering/Application Information

1. Standard package: 10 BISG-60/115-02 | 10 BISG-24-01 assemblies per box. (One BISG will install on one insulator).

2. Related test report: EDR-5310, EDR-5517-Bus Insulator Squirrel Guard (BISG-24-01).

BCAC

Bushing Connection Animal Cover



BCAC-5D/8

These insulating covers are designed to prevent animal caused outages on bushings ranging from 15 to 36 kV. They fit a wide range of bushing sizes and are suitable for substation and distribution applications.

RELIABLE OUTAGE PROTECTION

TE's insulating covers have been successfully eliminating outages from all types of animals for years. These covers have been designed to provide the same great protection with enhanced features.

FAST AND VERSATILE INSTALLATION

These BCACs are fast and easy to install. No trimming is required and they fit a wide range of bushing skirt diameters (see chart below). If needed, they can be installed on energized equipment as well. The feathered edges of these covers allow for conductor exits in both vertical and horizontal directions. These same edges act as thermal scan sites for true temperature evaluation of the covered hardware.

HIGH PERFORMANCE MATERIAL

Superior high-voltage outdoor materials are used in the BCAC cover design. The rugged, non-tracking, UV-resistant polymer ensures long-term performance even in the most extreme environmental conditions.

Selection Information: dimensions in millimeters

Catalogue Number	Max. Shed Diameter	Cover Height	Color
BCAC-5D/8 (B12)	122	203	Red
BCAC-7D/10 (B6)	172	266	Red
BCAC-8D/14 (B6)	203	355	Red
BCAC-G-5D/8 (B12)	122	203	Gray
BCAC-G-7D/10 (B6)	172	266	Gray
BCAC-G-8D/14 (B6)	203	355	Gray



BCAC-8D/14

Ordering/Application Information

- Standard package: 12 or 6 units per box, depending on size of cover. One BCAC will install on one insulator.
- Related test reports: EDR-5339, EDR-5407, UVR-8209

Selection Information: dimensions in millimeters

Catalogue Number	Max. Shed Diameter	Cover Height	Color
BCAC-BYPASS-01 (B6)	172	266	Red
BCAC-BYPASS-02 (B6)	203	355	Red



BCAC-BYPASS

BCAC-IC

Bushing Connection Inspection Cover



BCAC-IC-8D/18

This insulating cover is designed to prevent animal caused outages on breaker and transformer bushings ranging from 15 to 36 kV.

FAST AND VERSATILE INSTALLATION

The cover is easily installed around bushings and connections by wrapping the double hinged design around the insulator's top skirt and snapping it in place with a robust latching mechanism. The cover allows conductors to exit from both the top and side interfaces without the need to trim the cover. The design allows for visible inspections of oil fill levels on transformer bushings as well.

HIGH PERFORMANCE MATERIAL

Superior high voltage outdoor materials are used in the BCAC cover design. The rugged, non-tracking, UV resistant, high temperature polymer ensures long-term performance even in the most extreme environmental conditions.

Selection Information: dimensions in millimeters

Catalogue Number	Std. Pack	Color	Insulator Core Range	Insulator Shed Range	Cover Size
BCAC-IC-5D/6 (B6)	6	Red	38 - 89	63 - 127	127 dia, 152 ht
BCAC-G-IC-5D/6 (B6)	6	Gray	38 - 89	63 - 127	127 dia, 152 ht
BCAC-IC-7D/12 (B6)	6	Red	76 - 124	95 - 178	178 dia, 305 ht
BCAC-IC-8D/18 (B6)	6	Red	90 - 160	100 - 200	200 dia, 455 ht
BCAC-G-IC-7D/12 (B6)	6	Gray	76 - 124	95 - 178	178 dia, 305 ht
BCAC-G-IC-8D/18 (B6)	6	Gray	90 - 160	100 - 200	200 dia, 455 ht



BCAC-IC Installed on Bushings

Ordering/Application Information

1. Related test reports: EDR-5514, UVR-8209

The BCAC-IC covers are also kitted for voltage regulator applications. The kit includes two bushing covers and a center arrester cover.

BCIC

Bus Connection Insulating Covers



BCIC covers are designed to protect energized conductors or busbars from flashovers due to contact from birds, squirrels and other wildlife. BCIC parts are made from a UV stable, track resistant, high performance TE Connectivity material to ensure years of reliable service.

A variety of different shapes and sizes are available to cover circuit breaker bushings, bus standoff insulators, capacitors, transformer bushings, voltage regulators, potential transformers and more.

The parts shown are the most commonly used. Many other parts for different equipment arrangements are available. See your local TE representative for more options.





Installation can be made quickly in the field by trimming the entry and exit holes to the required dimensions. The BCIC covers can be re-entered for other maintenance needs and then reused, thus lowering overall lifetime costs.

Section 2



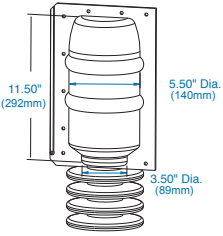
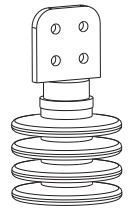

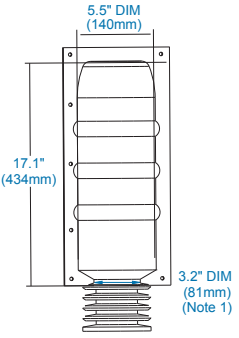
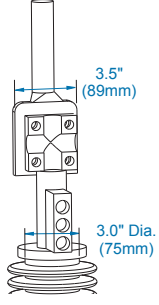
Selection Information: dimensions in inches (millimeters)

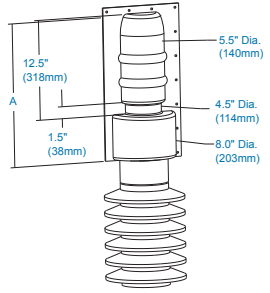
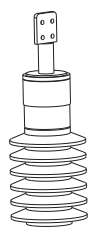
Bushing Covers	Installed Product	Hardware Configuration
BCIC-4D/4 (B3)		Uses 5 BCIC Latches
BCIC-5D/6 (B3)	NOTE No opening, must be field cut	Uses 5 BCIC Latches

Selection Information: dimensions in inches (millimeters)

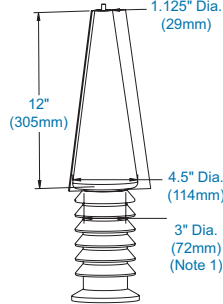
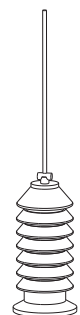

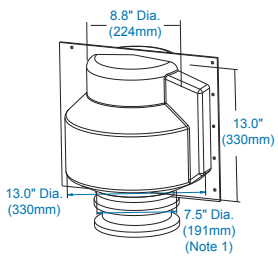

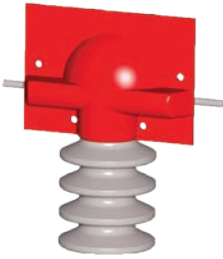
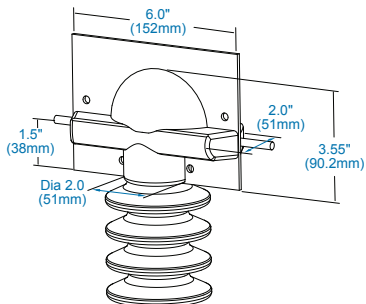
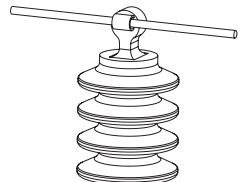
Bushing Covers	Installed Product	Hardware Configuration
		
BCIC-5.5D/11 (B3)	Bushing Range Diam. 2 - 3.5 NOTE No opening	Uses 9 BCIC Latches
		
BCIC-5.5D/16-HO (B3)		Uses 7 BCIC Latches
		
BCIC-8D/15H0 (B3) BCIC-8D/18-H0 (B3)	Dim. A = 16.2 (411) Dim. A = 19.2 (488)	Uses 10 BCIC Latches

Selection Information: dimensions in inches (millimeters)

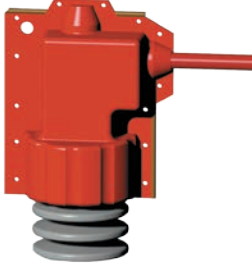
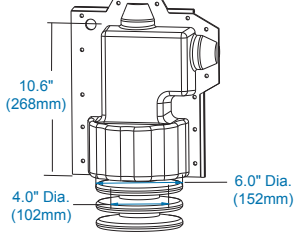
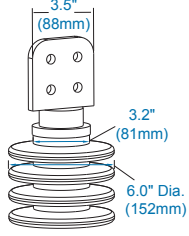

Bushing Covers	Installed Product	Hardware Configuration
		
BCIC-SG-101-H2 (B3)	NOTE Bottom and top opening	Uses 5 BCIC Latches
		
BCIC-13D/13-H0 (B3)	NOTE No opening, must be field cut	Uses 10 BCIC Latches
		
BCIC-3D/6-3 (B3)		Uses 4 BCIC Latches

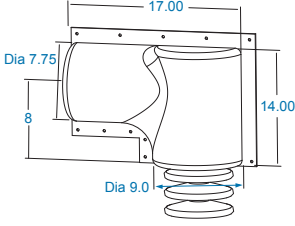
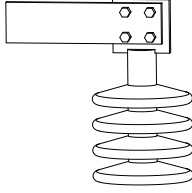
Section 2

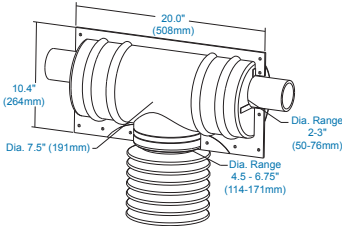
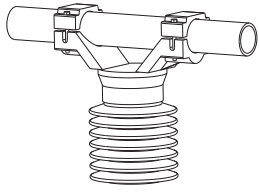
Selection Information: dimensions in inches (millimeters)

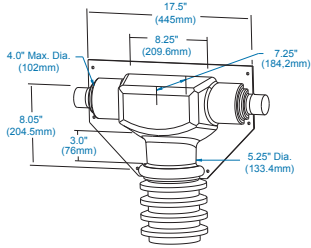
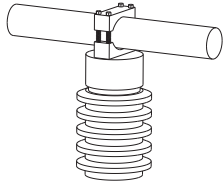
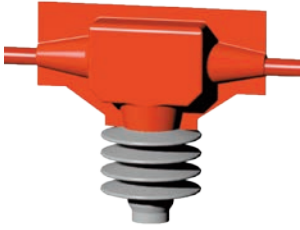
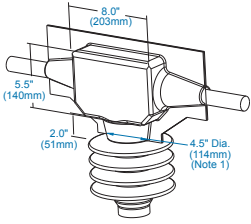
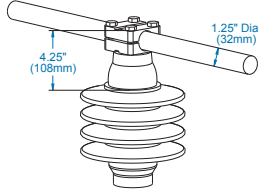

Bushing Covers	Installed Product	Hardware Configuration
		
BCIC-4411 (B3)	<p>NOTE 4" (100 mm) Bottom port opening</p>	Uses 13 BCIC Latches
		
BCIC-10D/18-3 (B3)		Uses 11 BCIC Latches
		
BCIC-75D/18-3 (B3)	<p>Bus Bar Diam. 2 - 3 (50 - 75) Angle Bus Double 3 (75)</p>	Uses 8 BCIC Latches

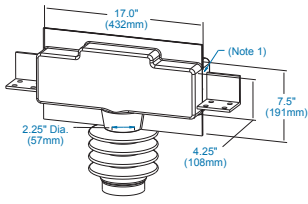
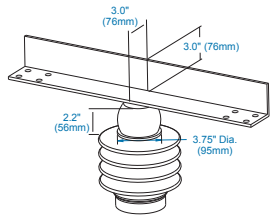
Selection Information: dimensions in inches (millimeters)

Bushing Covers	Installed Product	Hardware Configuration
		
BCIC-SG-201 (B3)	Max. Bus Bar Diam. 4 (100)	Uses 10 BCIC Latches
		
BCIC-TR205-R (B3)	NOTE 4.5" (114) Diam. Bottom port opening	Uses 10 BCIC Latches
		
BCIC-TR205-L (B3)	NOTE No opening, must be field cut	Uses 10 BCIC Latches

Section 2

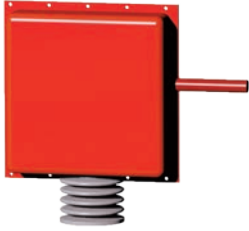
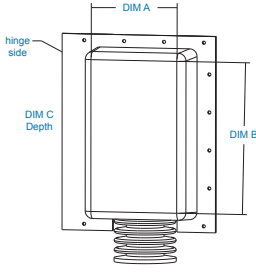
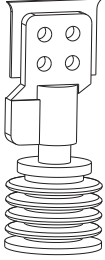
Selection Information: dimensions in inches (millimeters)

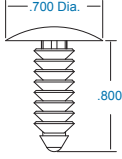
Bushing Covers	Installed Product			Hardware Configuration
				
	Dim A	Dim B	Dim C	
BCIC-12/12/5-H (B3)	12 (305)	12 (305)	5 (127)	Uses 12 BCIC Latches
BCIC-14/19/6-U (B3)	14 (356)	19 (483)	6 (152)	Uses 16 BCIC Latches
BCIC-24/11/12-U (B3)	11 (279)	24 (610)	12 (304)	Uses 16 BCIC Latches
BCIC-4/12/4-H (B3)	4 (102)	12 (305)	4 (102)	Uses 12 BCIC Latches
BCIC-7/12/7-H (B3)	7 (178)	12 (305)	7 (178)	Uses 12 BCIC Latches
BCIC-4/16/4-H (B3)	4 (102)	16 (406)	4 (102)	Uses 12 BCIC Latches
				NOTE Must be field cut
				
BCIC-LATCH (B250)	Std. Pack = 250 Latches or 1000 Latches			

MVFT

Medium Voltage Fusion Tape

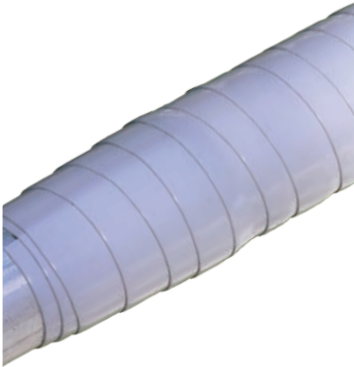

Medium Voltage Fusion Tape (MVFT) is a self amalgamating tape that provides insulation enhancement and protection against accidentally induced discharge. MVFT tape is designed to combine the integrity of a silicone polymer with the versatility of a wraparound product.

FAST AND VERSATILE INSTALLATION

MVFT tape is quick and easy to install. Upon application the tape amalgamates the over-lapped layers together, producing a complete seal. A single layer of MVFT tape, two-thirds overlapped, will provide AC voltage withstand (flashover protection) to at least 15 kV increasing to 35 kV if a second layer is applied. Although MVFT tape will stick to itself and other insulating materials, it will not adhere to metal or porcelain allowing easy removal for maintenance.

FEATURES

MVFT tape is compatible with all other products in the Raysulate MV Insulation enhancement system. This fusion tape is suitable for both Indoor and outdoor use. MVFT tape exhibits non-tracking properties and possesses a continuous operating temperature up to 90 °C.

APPLICATIONS

MVFT tape offers a simple and effective solution to the problems of retrofit insulation of busbars particularly where existing equipment cannot be dismantled. It can be used for indoor and outdoor applications and is easily installed over a wide variety of shapes including complex connections.

Section 2

Selection Information: dimensions in millimeters

Catalogue Number	Color	Width UOM: (mm)	Supplied Length UOM: (M)	Std. Pack
MVFT-G-2-12 (B4)	Gray	50	11	4 Rolls

Product Information

EDR-5465 Medium Voltage Fusion Tape Qualification Report

MVCC

Medium Voltage Conductor Covers for Outage Prevention



Medium Voltage Conductor Covers (MVCC) provide high quality electrical insulation for substation leads and jumpers. These covers are made from a non-tracking silicone material that is suitable for harsh medium voltage outdoor environments. MVCC covers are split for easy installation.

The MVCC's flexibility allows installation on tight bends which makes it ideal for substation applications.

These covers are designed to protect energized conductors from flashovers due to contact from birds and animals. The Medium Voltage Conductor Cover is suitable for applications up to 25 kV phase to ground. They are currently available in four sizes that will fit conductors with diameters ranging up to 44 mm.

Product selection information: dimensions in millimeters

Catalogue Number	Use range UOM: (mm)	Color	Conductor diameter supplied length UOM: (M)
MVCC-10/.40 (B100)	up to 11	Red	1 piece @ 30,4
MVCC-G-10/.40 (B100)	up to 11	Grey	1 piece @ 30,4
MVCC-19/.75 (B50)	11 - 19	Red	2 piece @ 7,6
MVCC-G-19/.75 (B50)	11 - 19	Grey	2 piece @ 7,6
MVCC-25/1.0 (B25)	19 - 28	Red	1 piece @ 7,6
MVCC-G-25/1.0 (B25)	19 - 28	Grey	1 piece @ 7,6
MVCC-45/1.75 x 4 (B24)	28 - 44	Red	6 piece @ 1,2
MVCC-G-45/1.75 x 4 (B24)	28 - 44	Grey	6 piece @ 1,2

Product Information

Related Test Report: EDR-5461 Medium Voltage Conductor Cover Electrical Testing





Section III Overhead

MVLC Medium Voltage Line Cover (5 - 36 kV).....	28
BCIC Birdcap Protection Covers	30
BCIC Dead End and Suspension Clamp Covers	32
BCAC BCIC Distribution Covers for Animal Protection	33
AFD Avian Flight Diverter	34

MVLC

Medium Voltage Line Cover (5 - 36 kV)



The MVLC cover is a cold-applied wrap-around cover that provides retrofit insulation for overhead conductors to help prevent electrical outages caused by incidental contact from tree branches or wildlife.

The MVLC cover may be applied selectively on problem spans to avoid costly conductor replacement. Installation is possible on energized lines utilizing the MVLC tool which attaches directly to the overhead conductor and remains stationary in a single location. The tool may be manually or automatically operated, using a powered drill. The tool forms, closes, and feeds the MVLC cover along the conductor with speed and consistency. The MVLC hand tool allows for quick installation on short lengths of conductors, especially in substations.

NOTE Installation on energised line must only be carried out by "Live Line" trained installers

Product selection information: dimensions in millimeters

Covers for overhead conductors

Product Size	Conductor Size	Max Conductor Diam.	Voltage Class
MVLC-14-A/U-C-100	up to 99 mm ²	12,7	15 kV
MVLC-14-A/241-C-100	up to 99 mm ²	12,7	25 kV
MVLC-18-A/U-C-75	up to 185 mm ²	18	15 kV
MVLC-18-A/241-C-75	up to 185 mm ²	18	25 kV (sealing mastic in receptacle)
MVLC-38-A/U-C-50	up to 800 mm ²	38	15 kV
MVLC-38-A/241-C-50	up to 800 mm ²	38	25 kV (sealing mastic in receptacle)

Installation tools for overhead conductors

Product Size	Conductor Size	Max Conductor Diam.
MVLC-14-TOOL-100	for use with MVLC-14	15 - 25 kV
MVLC-18-TOOL-03-2006	for use with MVLC-18	15 - 25 kV
MVLC-HAND-TOOL-14	hand tool for installing MVLC-14	-
MVLC-HAND-TOOL-02	hand tool for installing MVLC-18 and 38	-

Ordering/Application Information

- Two pieces of MVLC can be used with S1251 to make cover splices
- MVLC Standard pack sizes:
MVLC-14 is 100M
MVLC-18 is 75M
MVLC-38 is 50M
- Please contact TE Connectivity for use on 36 kV and above and for other sizes
- Related Test Reports: EDR-5308, EDR-5309, EDR-5316, EDR-5386, EDR-5478
- MVLC TOOL contains the MVLC Installation Tool, MVLC Cutters, Hand Crank and a drive nut and socket packaged in a protective bag.
- MVLC can be installed at temperatures above 0°C.

Product Performance

Test		MVLC-A/U / MVLC-A/241 (Sealed)	
AC withstand (dry) - 1 minute		15 kV min / 25 kV min	
AC withstand (wet) - 1 minute		15 kV min / 25 kV min	
AC long term withstand (dry) - 4 hours		8,6 kV min / 14,4 kV min	
30 day thermal loading (8 hr @ 130°C; 16 hr off)		No MVLC deformation	
Conductor ampacity		82 - 89% of bare conductor ampacity	
Material properties per pps 3010/42		Test Method	Requirement
Physical	Tensile Strength Ultimate Elongation Abrasion Resistance Low Temperature Impact	ASTM D638 ASTM D638 1000 cycles, 2068g ASTM D746	-
Electrical	Dielectric Strength Tracking and Erosion Resistance	ASTM D149 ASTM D2303 Step Voltage Method (Initiate @ 2,5 kV)	217 kV/cm @ 1,27 mm No tracking or erosion to top surface or flame failure after: 200 minutes



Installation Tool for Overhead Conductors



MVLC-HAND-TOOL-14



MVLC-HAND-TOOL-02

Section 3

For busbar applications

MVLC combination	Single busbar (mm)	Double busbar (mm)
2 x MVLC-18	60 x 10	-
2 x MVLC-38	80 x 10	2 x (60 x 10)
2 x MVLC-38	100 x 10	2 x (80 x 10)
2 x MVLC-38	120 x 10	2 x (100 x 10)
1 x MVLC-18 2 x MVLC-38	-	2 x (120 x 10)

MVLC combination	Round busbar diameter (mm)
1 x MVLC-14	14
1 x MVLC-18	18
1 x MVLC-38	38
3 x MVLC-18	45
3 x MVLC-18	50
3 x MVLC-18	60
2 x MVLC-18 1 x MVLC-38	75 to 100

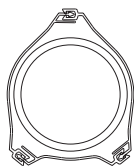

70 mm to 100 mm busbar with 2 x MVLC-38 and 1 x MVLC-18



2 Pieces: MVLC-38 on busbar with BCIC

Nominal dimensions (mm)



MVLC-14

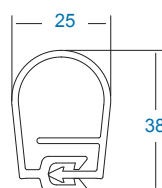

MVLC-18

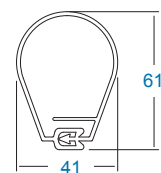

MVLC-38

BCIC

Birdcap Protection Covers



The Birdcap family of insulating covers are specifically designed to protect birds from causing flashovers during take-off, landing and perching on energised conductors at crossarm and poletop insulators. This also protects the network from outages and potential damage to equipment and conductors.

Birdcaps are available in three materials, from a high performance, UV stable, track resistant Raychem material to a fit for function M.V. and Low Pollution environment material to a UV stable grade clear material for enhanced clarity during aerial visual inspection in remote locations.

A variety of different shapes and sizes are available to cover different support insulator/insulator interfaces at transmission and distribution voltage classes.

Installation can be made quickly in the field by Cable-Ties, Latches, Screws or Hotsticking on live conductors.

Covers for overhead conductors

Material Options	Features	Benefits	Test Report
Raychem Red: UV stable, track, chemical and pollution resistant. Crosslinked for high thermal stability. Flexible for curved installation at double insulator pole arrangements	Crosslinked Excellent TERT Good Dielectric Strength UV Stable Flexible	25 years lifetime in harsh environment of high pollution, high sun exposure and low rain fall	EDR-5385
LDPE Black: Suitable for MV networks in less harsh environments.	Good TERT Good Dielectric Strength Flexible	Meets requirements for less harsh environment. ~15 years service life	PPR-2958
Polyester Clear: UV Stable grade for easy inspection of connections	High Dielectric Strength See through	~10 years service life	PPR-2959



BCIC-1215: Double Post Insulator application



BCIC-1219-PE: Post Insulator application



BCIC-1217-TR: Post Insulator application



BCIC-TEN-01: Tension Insulator application

Selection tables: dimensions in millimeters

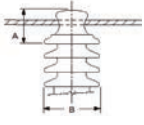
Insulator Size (mm)	BCIC-xxxx Family Part Descriptions									
	1215	1216	1217	1218	1219	1215-005	1215-006	3313	3314	
	A	A min = 40 A max = 150	A min = 40 A max = 150	A min = 40 A max = 150	A min = 40 A max = 150	A min = 40 A max = 150	A min = 90 A max = 130	A min = 90 A max = 130	A min = 60 A max = 120	A min = 60 A max = 120
	B	B min = 90 B max = 190	B min = 90 B max = 190	B min = 90 B max = 190	B min = 90 B max = 190	B min = 90 B max = 190	B min = 90 B max = 185	B min = 90 B max = 185	B min = 130 B max = 160	B min = 130 B max = 160
Conductor Size (mm ²)	70 - 120	25 - 120	25 - 150	70 - 120	25 - 150	70 - 120	70 - 120	25 - 300	25 - 300	
Length (mm)	1,400	1,400	1,400	1,400	1,400	1020	1150	1,380	1,380	
Fixing Method	Integral Clips	Integral Clips with Plastics Screws	Plastics Screws	Integral Clips with Plastics Screws	Cable Ties	Integral Clips	Integral Clips	Metal Hose Clamps	Metal Hose Clamps	
Material Options	Raychem Red LDPE Black	Raychem Red LDPE Black	Raychem Red LDPE Black Polyester Clear	Raychem Red LDPE Black	Raychem Red LDPE Black	Raychem Red	Raychem Red	Raychem Red	Raychem Red	
Live Installation	Yes	No	Yes	Yes	No	Yes	Yes	No	No	
Pack Sizes	3 or 36	3 or 36	3 or 36	36	3 or 36	50	10	3 or 24	3 or 24	

Basic shapes

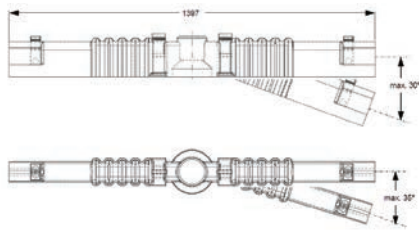

BCIC-1215/16/17/18/19

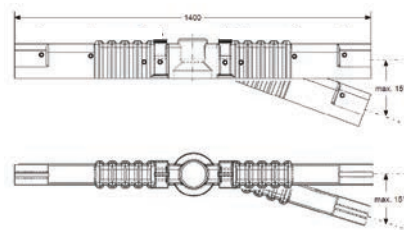

BCIC-1217-TR

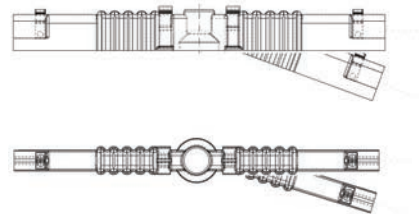

BCIC-1215-005/006

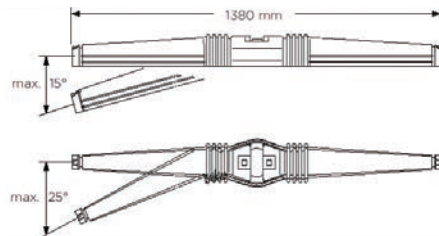

BCIC-3313/14

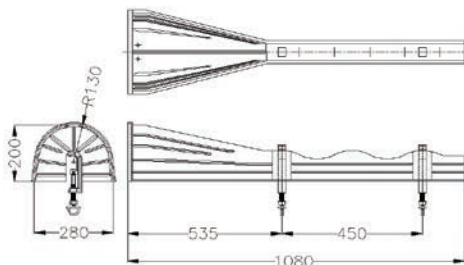

BCIC-TEN-01

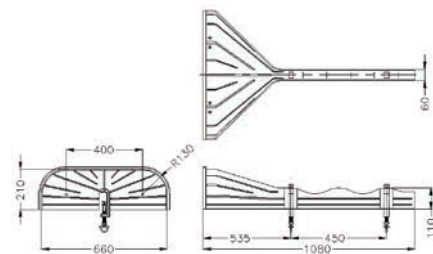

BCIC-TEN-03

For further assistance contact your local TE representative

BCIC

Dead End and Suspension Clamp Covers



BCIC covers for Dead End connection points and Suspension Clamps protect energised lines from perching, landing and nesting birds.

When used together with an overhead line cover they combine to make an effective insulation enhancement system against accidental phase-phase or phase-ground touches.

They use the same high performance material as the Birdcaps and substation BCIC's and are suitable for MV Poles and HV Towers.

Selection Information: dimensions in millimetres

Bushing Covers	Product Dimensions in inches (mm)	Application
BCIC-9/10/3-L (B3)		
BCIC-10/13.5-L (B3)		
BCIC-4.75/11-3 (B12)		
BCIC-7/20-4 (B6)		
BCIC-H3-2-7(B12)		

BCAC | BCIC

Distribution Covers for Animal Protection



BCAC-G-5D/8-01
BCAC-G-AR-5D-2

These insulating covers are designed to prevent bird caused outages on distribution equipment ranging from 15 to 36 kV. Covers are available for terminations, reclosures, lightning arresters, and fuse cutouts.

TRANSFORMER BUSHING

The BCAC-4D/13 - 2 covers a wide variety of termination sizes. The cover is easily installed on top of the first termination skirt. No trimming is required and the cover fits terminations ranging in size from 45 to 380 mm². Extensive testing has ensured that the cover will not damage or deteriorate the terminations.

FAST AND VERSATILE INSTALLATION

These BCACs are fast and easy to install. No trimming is required and they fit a wide range of bushing skirt diameters. If needed, they can be installed on energized equipment as well. The feathered edges of these covers allow for conductor exits in both vertical and horizontal directions. These same edges act as thermal scan sites for true temperature evaluation of the covered hardware.



BCAC-4D/13-2

LIGHTNING ARRESTER CAPS

Distribution surge arrester caps protect against unwanted animal and bird outages. The unique design covers the first skirt which improves the level of protection. The cap is easily installed and attaches to both the stud and the conductor so that it will stay secure even in high winds. Three different covers are available.

FUSE CUTOUTS

The BCAC-G-CUTOUT hot-stickable insulating cover is designed to protect fused cutout switch applications up to 25 kV. The unique omega shaped attachment area easily clips onto the cutout insulator between the first and second skirt. The insulated conductor is captured securely as well to ensure retention even in high winds. Two different covers are available for 100 and 200 amp applications.



BCAC-G-CUTOUT-100-01

HIGH PERFORMANCE MATERIAL

Superior high voltage outdoor materials are used in all of these BCAC cover designs. The rugged, track resistant, UV resistant polymer ensures long-term performance even in the most extreme environmental conditions.

Selection Information: dimensions in millimeters

Catalogue Number	Hardware
BCAC-4D/13-2 (B18)	Terminations
BCAC-5D/8-01 (B12)	Transformer Bushing
BCAC-AR-5D-2 (B24)	Ohio Brass Arrester
BCAC-AR-4D-2 (B24)	TE Arrester
BCAC-AR-3.75D-2 (B24)	Cooper Arrester
BCAC-G-CUTOUT-100-01 (B12)	Fuse Cutout Switch (100 AMP) Porcelain Style
BCAC-G-CUTOUT-200 (B3)	Fuse Cutout Switch (200 AMP) Porcelain Style
BCAC-G-CUTOUT-100-P2 (B12)	Fuse Cutout Switch (100 AMP) Polymeric Style
BCAC-G-CUTOUT-FT-P (B3)	Fuse Cutout Switch (200 AMP) Polymeric Style

AFD

Avian Flight Diverter



TE Connectivity's Avian Flight Diverter is designed to aid birds in seeing overhead lines and avoid collisions. By drawing attention to the lines earlier, large fowls such as geese and swans will have enough time to change their direction and avoid potentially fatal consequences.

The Avian Flight Diverter is compatible with all types of conductors and is RFI free to 69 kV. The diverter incorporates a high visibility prismatic reflecting strip that allows birds to see the diverter even in low light and fog conditions. A glow in the dark strip is also used to extend the diverter's effectiveness at dusk, for birds returning to their roosts. The materials used in the diverter are extremely UV stable, track resistant, and are designed to give superior performance for many years of service.

FAST AND EASY INSTALLATION

The diverter is easily installed with a hot stick on conductors ranging from diameter 4 to 22 mm.

KEY FEATURES

- Hot stickable, easy to install
- Range taking 4 to 22 mm diam.
- High reflectivity
- Glow strip for dusk
- Removable



BCIC-AFD-01 Hot-stick Installation



BCIC-AFD-01 Hot-stick twist off

Product Selection Information: dimensions in millimeters

Catalogue Number	Description	Dimensions Width x Height	Conductor size (mm)	Standard pack
CU7208-000	BCIC-AFD-01 (B10)	102 - 89	4 - 22	10

Overhead Line Spacing, Meters

Single Phase	2,4	
Three Phase	7,2	

Technical Report

EDR—5536, Rev. A

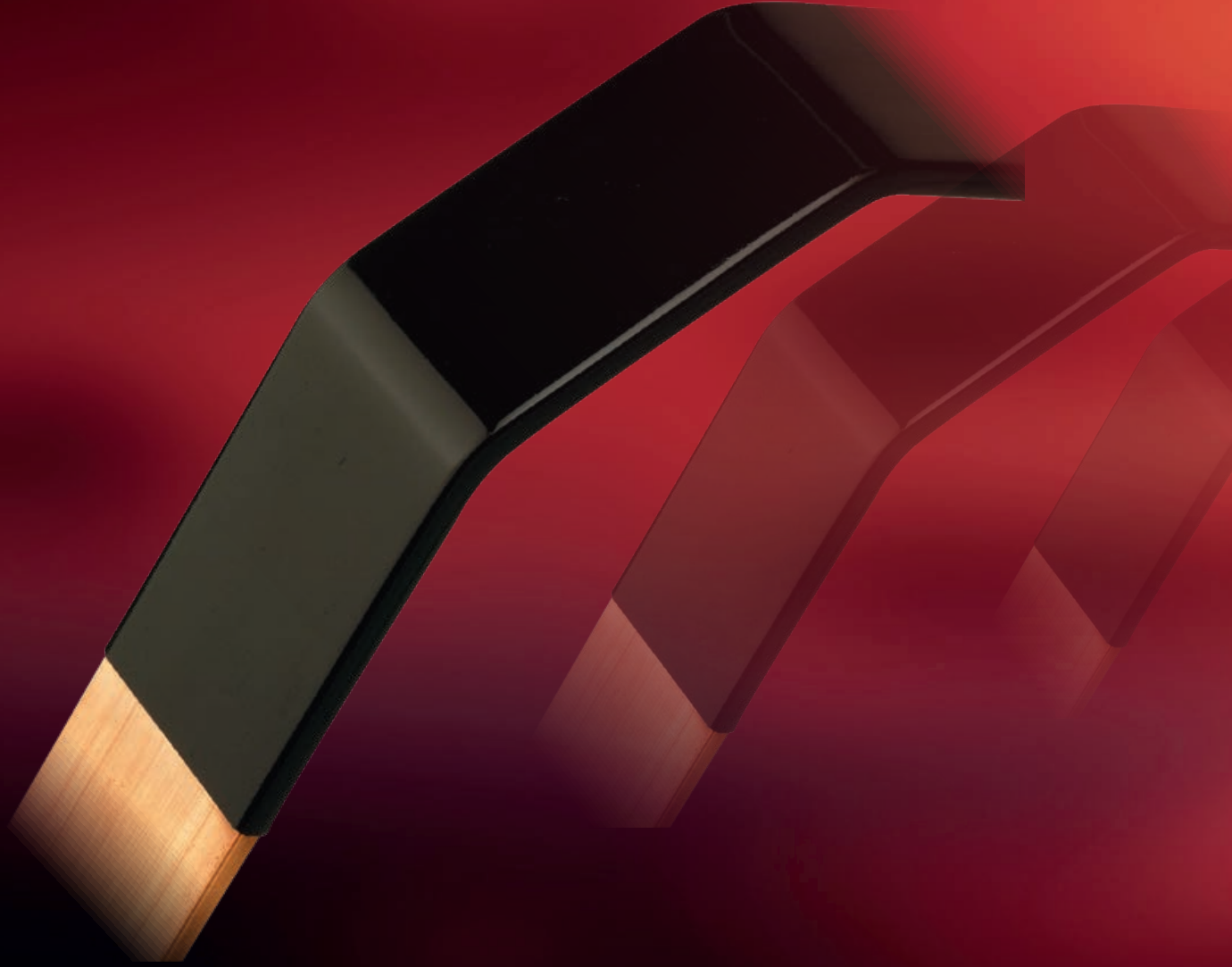

Section IV Low Voltage

- LVIT Tube**
Low Voltage Insulation Tubing (0 - 1 kV)38
- LV BMOD**
Modular Busbar Insulation Connection Covers 39
- LVIC**
Low Voltage Insulating Covers 40
- LVBC**
Low Voltage Bushing Covers..... 42

LVIT

Low Voltage Insulating Tubing (0 - 1 kV)



PRODUCT DESCRIPTION

- Raychem black, medium wall, flame retarded heat-shrinkable tubing LVIT is suitable for insulating busbars up to 1 kV.
- This highly flexible tubing can be used on a variety of curved and bent busbars of both circular and rectangular cross-section.
- Raychem tubing LVIT can be easily installed in a factory environment using an oven or in the field using a gas torch or hot air.
- Raychem tubing LVIT is manufactured in UV resistant material, making it suitable for both indoor and outdoor applications.

APPLICATIONS

- Raychem tubing LVIT is suitable for both enclosed and exposed busbars and for connections in switchgear, substations, motor control centers and other electrical equipment.

FEATURES/BENEFITS

- Compatible with all other products in the Raychem low voltage insulation range.
- Flame retarded.
- Continuous operating temperature rating up to 105°C.
- High shrink ratio reduces inventory and simplifies product selection.
- Suitable for indoor and outdoor applications.
- Good thermal emissivity and contact with busbars means no derating is needed.
- Can be stored indefinitely at temperatures up to 50°C without loss of performance.
- UL approved.

Raychem Low Voltage Busbar Insulation Tubing LVIT

Key product specifications	Test method	Requirement
Thermal endurance	IEC 216	105°C min
Low temperature flexibility	ASTM D2671 Procedure C	No cracking after 4 hrs @ -40°C
Flammability	IEEE 27, ANSI C37.20, IEC 332, BS 4066	Self-extinguishing 60 sec max
Water absorption	ISO 62, ASTM D570	24 hrs @ 23°C, 0,2% max
Resistance to transformer oil - Tensile strength - Ultimate elongation	VDE 0370	168 hrs @ 23°C 11 MPa min 300% min

NOTE For further product specification information see Raychem PPS 3010/06

Product selection

Raychem tubing LVIT should normally be used on the following busbar sizes



Product size	Rectangular busbars, L+T (mm) min	Rectangular busbars, L+T (mm) max	Round busbars, D (mm) min	Round busbars, D (mm) max
LVIT-30/10-A/U-4	17	39	11	25
LVIT-75/25-A/U-4	39	86	27	55
LVIT-100/35-A/U-4	59	117	38	75
LVIT-150/50-A/U-4	86	157	55	100
LVIT-175/70-A/U-4	117	190	75	120
LVIT-235/105-A/U-4	190	280	120	180

Technical Report

UVR 8148 -Qualification report for LVIT

UVR 8153 -LVIT testing for Hong Kong Electric

UVR 8165 -Damp heat cycling on LVIT

Ordering information

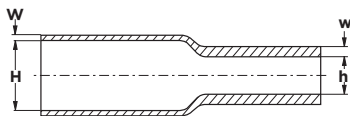

Ordering description	Dimensions (mm) H min	Dimensions (mm) h max	W nom.	w min	UOM: roll of length (m)
LVIT-30/10-A/U-4	30	10	0,5	1,5	60
LVIT-75/25-A/U-4	75	25	0,5	1,5	30
LVIT-100/35-A/U-4	100	35	0,5	1,5	60
LVIT-150/50-A/U-4	150	50	0,5	1,5	30
LVIT-175/70-A/U-C	175	70	0,5	1,5	100
LVIT-235/105-A/U-4	235	105	0,5	1,5	25

NOTE W, H = as supplied w, h = after free recovery. Maximum longitudinal change after free recovery: +5% -15%. Maximum eccentricity: 40% (as supplied). Fit the larger size of LVIT if two sizes fit the required application. Installation instructions EPP 0620 5/96 and Material Safety Data Sheet available on request.

LV BMOD

Busbar Insulation Connection Covers

Raychem cold applied busbar insulation covers Voltage Class 1 kV, application range 50 mm, 75 mm and 100 mm.

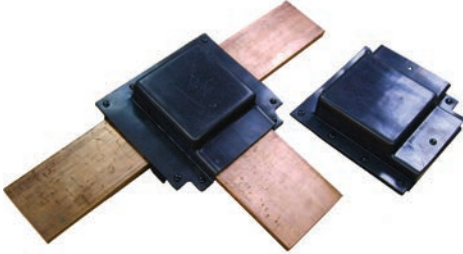

PRODUCT DESCRIPTION

- The BMOD family of busbar covers are designed to protect and insulate energised busbars from flashover due to accidental contact in confined spaces.
- They can be used on bare busbars, switchgear connections, substations and other electrical equipment.
- Cold applied half-shells are fixed with easy push fit latches for retro-fit installation and can be removed and reused.
- Compatible with all other TE and Raychem heatshrink tubes and tapes.

APPLICATIONS

- Allows equipment designers to reduce air spacings between busbars when used in conjunction with TE and Raychem heatshrink tube or tape.
- Provides flashover protection for up to 1 kV on the Low Voltage systems, Black covers "Tee", "Elbow" and "Straight" connection.
- 1 x 1 Busbar combinations. Maximum bar thickness 12 mm.
- Pack size 12.

FEATURE AND BENEFITS

- Made from Raychem LVBS Sheet.
- Suitable for indoor and outdoor use.
- Flame Retarded.
- Operating temp rating up to +105°C.
- Compatible with LVIT and LVBT.
- Low Toxicity performance.
- Can be easily removed for inspection and maintenance.

Raychem BMOD Insulation Covers

Part Number Description		
LV	Low Voltage system	1 kV
050 075 100	Busbar size x 12 mm max	50 mm 75 mm 100 mm
T L S	Connection shape	Tee Elbow Straight
11	1x1 Busbar Combination	
00 01 02	Hand arrangement	Straight Right Hand Left Hand
(B12)	Pack size	12

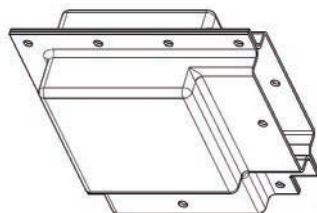
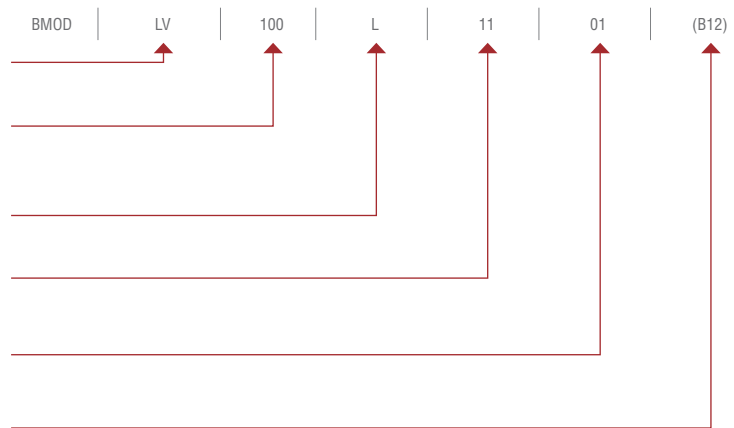

BMOD-LV-100-L-11-01 (B12)

BMOD Cover for LV, 100 mm x 12 mm single busbar, "L" Right Hand Angle, pack of 12

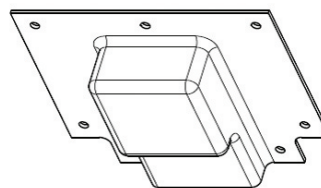

BMOD-LV-050-T11-00 (B12)

BMOD Cover for LV, 50 mm x 12 mm single busbar, "Tee" Shape, pack of 12

LVIC

Low Voltage Insulation Covers

PRODUCT DESCRIPTION

- The LVIC range of insulating covers consists of a number of pre-formed insulating shapes for multiple bar connection arrangements.
- They can be used on bare busbars, switchgear connections, substations and other electrical equipment.
- Cold applied half-shells are fixed with easy push fit latches for retro-fit installation.
- Compatible with all other TE and Raychem heatshrink tubes and tapes.

APPLICATIONS

- Allows equipment designers to reduce air spacings between busbars when used in conjunction with TE and Raychem heatshrink tube or tape.
- Provides flashover protection for up to 1 kV on the Low Voltage systems, Black covers.
- "Tee" and "Elbow" connection.
- Up to 4 x 4 Busbar combinations.
- To fit bar size 75 mm.
- Pack size 12.

FEATURES/BENEFITS

- Made from Raychem LVBS sheet.
- Suitable for indoor and outdoor use.
- Flame retarded.
- Operating temp rating up to +105°C.
- Compatible with LVIT and LVBT.
- Low Toxicity performance.
- Can be easily removed for inspection and maintenance.

Product Selection: LVIC Preformed parts

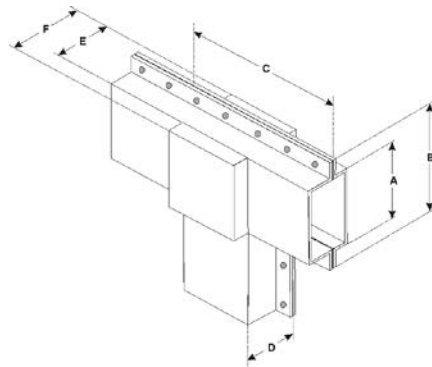

Part number	Recommended for busbar width (mm)	Busbars to be connected	Dimensions of part (nom) (mm)					
			A	B	C	D	E	F
LVIC 3210	75	1/1	80	124	290	11	11	62
LVIC 3221	75	2/1	80	124	290	14	32	72
LVIC 3220	75	2/2	80	124	290	32	32	77
LVIC 3232	75	3/2	80	124	290	32	50	90
LVIC 3230	75	3/3	80	124	290	50	50	95
LVIC 3343	115/75	4/3	118	162	290	50	70	110

UOM 1 kit (contains two formed halves plus fixings)

NOTE LVIC covers are located around busbar joints and held in place by clip action rivets (supplied). The covers can be removed and re-used as required.

Product Selection: LVIC Preformed parts

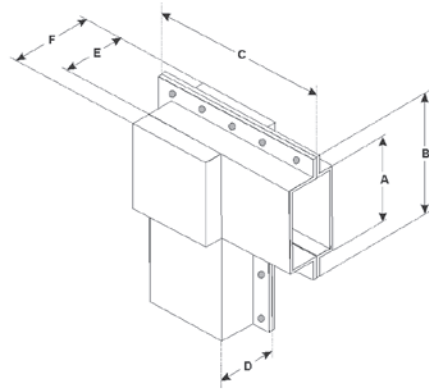

Part number	Recommended for busbar width (mm)	Busbars to be connected	Dimensions of part (nom) (mm)					
			A	B	C	D	E	F
LVIC 2210-01 LVIC 2210-02	75	1/1	63	79	148	33	42,5	62
LVIC 2220-01 LVIC 2220-02	75	2/2	63	79	148	33	42,5	62
LVIC 2230-01 LVIC 2230-02	75	3/3	63	79	148	33	42,5	62
LVIC 2343	115/75	4/3	80	118	200	50	70	110

UOM

1 kit (contains two formed halves plus clips)

LVBC

Low Voltage Bushing Cover

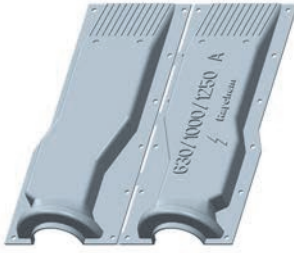

The LVBC range of insulating covers are designed to fit the LV Bushings on transformer according to EN-50386.

Made from the same Flame Retarded, Indoor/Outdoor material as LVIT heatshrink tube, LVBT heatshrink tape and the BMOD/LVIC products.

The covers are hinged, with push fit latches for easy cold applied fitting. This allows easy removal for inspection and then reuse.

Selection Information

Bushing Size EN-50386 (Amps)	Part Description	Pack Size
250	LVBC-DT3-250A (B12)	12
630	LVBC-DT-630/1250A (B12)	12
1,000		
1,250		
2,000	LVBC-DT3-2000A (B12)	12





Section V Contamination/Flashover Prevention

HVCE High Voltage Creepage Extenders.....	46
HVCE WA High Voltage Wraparound Creepage Extenders	47
HVBS High Voltage Booster Shed.....	48
RRGS Polymeric and Porcelain Rigid Red Guano Shield.....	49

HVCE

High Voltage Creepage Extenders



Heat-shrinkable creepage extenders help to increase the flashover performance of insulators by reducing the surface electrical stress and leakage current and increasing the creepage length of the insulators. The extenders are designed to be resistant to conventional spray washing techniques and will withstand most normal handling, abuse, and extreme weather conditions.

Selection Information: dimensions in millimeters

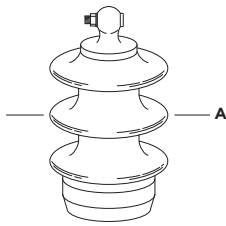

Catalogue Number	Skirt Diameter of Insulator (min – max)	Minimum Internal Diameter of HVCE (as supplied)	Nominal Creepage Extension Per Extender (mm)	Std. Pack (pcs/box)
	A			
HVCE 100/80-01 (B6)	81 - 99	114	100	6
HVCE 120/100-01 (B6)	99 - 119	135	100	6
HVCE 140/120-01 (B6)	119 - 140	155	100	6
HVCE 160/140-01 (B6)	140 - 160	178	100	6
HVCE 183/161-01 (B6)	160 - 183	203	100	6
HVCE 205/184-01 (B6)	183 - 206	229	100	6
HVCE 226/206-11 (B3)	206 - 226	239	100	6
HVCE 247/227-11 (B3)	226 - 246	262	100	6
HVCE 268/248-11 (B3)	246 - 267	282	100	6
HVCE 289/269-11 (B3)	267 - 290	302	100	6
HVCE 310/290-11 (B3)	290 - 310	323	100	6
HVCE 331/311-11 (B3)	310 - 330	345	100	6
HVCE 352/332-11 (B3)	330 - 353	366	100	6
HVCE 373/353-11 (B3)	353 - 373	386	100	6
HVCE 394/374-11 (B3)	373 - 393	409	100	6

Ordering/Application Information

1. Select the appropriate catalogue number. Confirm selection with insulator skirt outer diameter (A).
2. Each HVCE extender adds a nominal 100 mm to the creepage length. As a general recommendation, TE advises a 20 percent increase in existing creepage distance.
3. For applications that do not fall within the ranges above, contact your local TE representative.
4. HVCE does not upgrade the voltage class of the insulator.
5. Related test reports: UVR-8138, UVR-8144, UVR-8037, EDR-5350

HVCE-WA

High Voltage Wraparound Creepage Extenders



Each extender is tailored to suit the insulator or bushing profile used. There is a wide range of extenders already available, many of which fit the more commonly used profiles.

The range already covers many insulator and bushing profiles from approximately 200 mm to 600 mm in diameter. There is no upper voltage limit to the use of creepage extenders with applications in use >250 kV a.c. and d.c.

Selection Information: dimensions in millimeters

In order to select the appropriate size of HVCE, an insulator or section of an insulator must be obtained. Then measure accurately the dimensions of the shed diameter and outside profile of the shed at its farthest point. This can be done by breaking a piece of porcelain off of the insulator or by using a profile gauge. The vital measurements needed to select a creepage extender are shown below. The illustration (Diagram B) shows an example of a typical cross section of an HVCE with the dimensions representing that of the insulator profile.

A selection chart of already designed HVCE-WA's is available, for assistance please contact your local TE Representative.

		<p>Each HVCE-WA extender adds nominal 150 mm to the creepage length. As a general recommendation, TE Connectivity advises a 20% increase in existing creepage distance.</p> <p>Use the formula below to calculate the number of creepage extenders required:</p> <p>Existing creepage x 0,2 ÷ 150 = minimum number of creepers required</p> <p>ie) 1,500 x 0,2 ÷ 150 = 2 HVCE-WA's</p> <p>Always round up to the nearest whole number, ie) 1,33 = 2 HVCE-WA's</p>
--	--	---

Product Information

HVCE-WA does not upgrade the voltage class of the insulator or bushing.

Related test reports: UVR-8152, Qualification Report on Wraparound Creepage Extenders and EDR-5350, Clean Fog Test on Artificially Contaminated Creepage Extenders (HVCE & HVCE-WA)

HVBS

High Voltage Booster Shed



The Booster Shed is a loose fitting collar made from Raysulate anti-tracking polymer which is spaced from the porcelain skirt by short pegs and from the insulator core by spacers. Booster sheds prevent "heavy wetting" flashover by breaking up the water cascades from skirt to skirt. Booster sheds have also been proven to prevent ice-cascade-induced flashovers.

APPLICATIONS

- Circuit breaker bushings.
- Bus support insulators.
- Surge arresters.
- Transformer bushings

KEY FEATURES

- Wraparound installation speeds installation time since the connections don't need to be disconnected.
- Superior UV resistance.
- Anti-tracking material.

Selection Information: dimensions in millimeters

Catalogue Number	Suitable Insulator Core	Booster Shed Diameter Fully Installed
HVBS-615/155-01-M-BP	94 - 114	569
HVBS-665/205-01-M-BP	140 - 160	616
HVBS-685/225-01-M-BP	158 - 178	634
HVBS-710/250-01-M-BP	175 - 201	657
HVBS-740/280-01-M-BP	209 - 229	685
HVBS-770/310-01-M-BP	237 - 257	713
HVBS-835/375-01-BP	297 - 317	773
HVBS-865/405-01-BP	325 - 345	801
HVBS-900/440-01-BP	357 - 337	834
HVBS-910/450-01-BP	367 - 387	843
HVBS-930/470-01-BP	385 - 405	861
HVBS-980/520-01-BP	431 - 451	908
HVBS-1015/555-01-BP	464 - 484	940
HVBS-1040/580-01-BP	487 - 507	963
HVBS-1070/610-01-BP	515 - 535	991
HVBS-1105/645-01-BP	547 - 567	1024
HVBS-1130/670-01-BP	570 - 590	1047
HVBS-1160/700-01-BP	598 - 618	1075
HVBS-1195/735-01-BP	632 - 651	1107

Product Information

Related Test Report: UVR-8107 Qualification report for Booster Sheds

RRGS

Polymeric and Porcelain Rigid Red Guano Shield



The rigid red guano shield protects against bird streamer caused outages. There are designs to fit both porcelain bells and polymeric insulators. This two piece shield attaches easily with plastic bolts and nuts around the top of the insulator and provides protection from fecal contaminates coming from above the insulator string. For both applications there are 450 mm and 600 mm diameter shield designs.

Superior high-voltage outdoor materials are used in the RRGs shield design. The rugged, non-tracking, UV-resistant, high temperature polymer ensures long-term performance even in the most extreme environmental conditions.

There are a wide range of problems related to fecal contamination on other equipment arrangements. For further assistance, contact your local TE representative.

Selection Information: dimensions in millimeters

Catalogue Number	Insulator Type	Shield Diameter
RRGS-35/470-FT (B12)	Polymeric	450
RRGS-35/600-FT (B3)	Polymeric	600
RRGS-35/470-M (B12)	Porcelain	450
RRGS-35/600-M (B3)	Porcelain	600



Polymeric RRGs Shield



Porcelain RRGs Shield





Section VI Applications and Technical Specifications

Protection, Repair and Maintenance	52
Protection of Outdoor Equipment	53
Protection for Medium-Voltage Products.....	55



Protection, Repair and Maintenance

Raysulate applications



The Raysulate electrical insulation family of products offers easy-to-install busbar insulation systems for both the field engineer and the manufacturer. Raysulate electrical insulation products provide flashover protection against the accidental bridging of conductors commonly caused by birds and animals.

The system is ideal for both enclosed and exposed bus work and for connections in switchgear, substations, and other electrical apparatus. It also permits clearance reduction in many applications.

EXCELLENT ELECTRICAL AND THERMAL PERFORMANCE

Raysulate electrical insulation products are manufactured from high dielectric strength, radiation-crosslinked, heat-shrinkable and cold applied materials. The high-voltage materials are specially formulated to provide high resistance to arcing and tracking. All high-voltage and low-voltage materials provide high-thermal endurance throughout the range of switchgear operating temperatures. They offer field-proven reliability and long service life in harsh environments. In addition, these heat-shrink tubing, tape, and sheet products can be preformed and preshrunk in the customer's workshop, allowing easy, quick installation in the field.

COMPATIBILITY WITH OTHER INSULATING MATERIALS

All Raysulate heat-shrinkable and cold applied electrical insulation products are compatible with other solid switchgear insulating materials. Raysulate electrical insulating materials are not subject to stress crazing or embrittlement and are not adversely affected by common plasticizers used in conventional switchgear insulating materials.

FLAME-RETARDANT MATERIALS

Most Raysulate insulating materials pass the ANSI C37.20 switchgear insulation flammability tests.

Protection of Outdoor Equipment

Raysulate applications



For Protection, Repair and Maintenance

FOR PROTECTION, REPAIR, AND MAINTENANCE

Raysulate heat-shrinkable electrical and cold applied insulating tubes, tapes, and sheets provide a complete system for electrical repair and maintenance of enclosed or exposed buswork and for connections in switchgear and electrical equipment. They offer:

- Fast, easy installation and removal
- A flexible system to cover most conductor shapes and sizes
- Consistent, reliable installation
- Consistently high electrical and thermal performance
- Compatibility with conventional solid insulating materials
- Protection against flashovers
- Protection for endangered wildlife
- TE Connectivity assistance and support for testing and applications

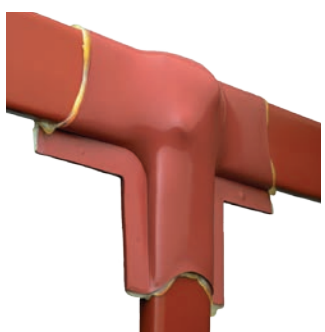

For the Electrical Equipment Manufacturers

FOR THE ELECTRICAL EQUIPMENT MANUFACTURERS

The Raysulate system of insulation-enhancement components addresses the needs of electrical equipment manufacturers. The superior material properties and versatility of these components enhance the quality and reliability of the final product. Raysulate electrical insulating materials feature:

- Low-hazard formulation
- Flexibility
- Track resistance
- Rugged, easy installation
- Excellent electrical and thermal performance
- Unlimited shelf life

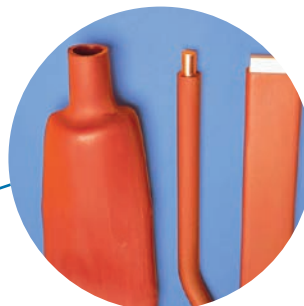
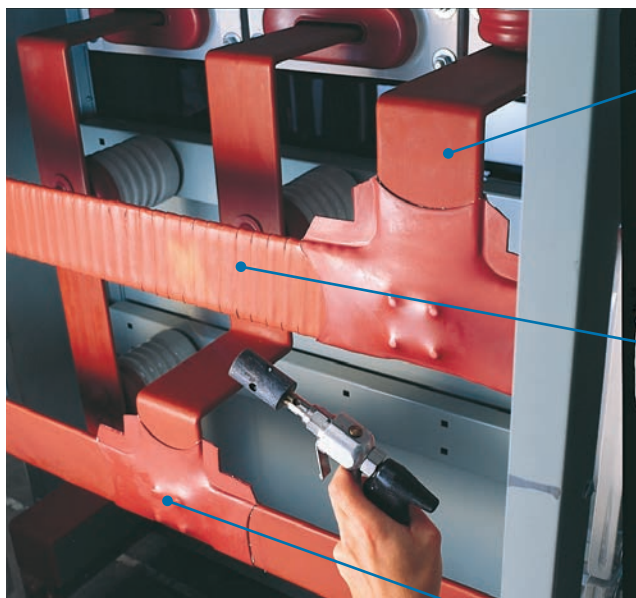

BBIT/BPTM
Bus Insulation Tubing



HVBT Bus Insulation Tape



HVIS Bus Insulation Sheet

Protection of Outdoor Equipment

Raysulate applications



MVLC-18-A/U Overhead Line Cover

FOR OUTDOOR EQUIPMENT

Raysulate electrical insulation products provide a complete system of insulation enhancement for highvoltage busbars and related equipment in outdoor substations and overhead lines. The system offers:

- Easy installation in the field
- Insulation for any different shapes, including busbars, joints, tees, insulators/ bushing connections
- Flashover protection against accidental bridging
- Protection of wildlife and from wildlife-induced outages
- Excellent UV and weathering resistance
- Protection against incidental tree branch contact



MVCC



HVCE



BCAC-IC-8D/18 Bushing Cover



BCIC-5D/6 Insulating/Bushing Cover



BISG-24

Medium-Voltage Products

Raysulate applications

Test and Performance Data

Material Properties	Test Method	Requirements	BBIT BPTM	BCIC HVIS	BCAC HVCE-WA HVBT*	HVCE	MVLC	RRGS BISG RRBB
Electrical								
Volume resistivity	ASTM D-257, IEC 93	ohm-cm min	1,0 x 10 ¹³	1,0 x 10 ¹³	1,0 x 10 ¹³	1,0 x 10 ¹³	1,0 x 10 ¹³	1,0 x 10 ¹³
Dielectric constant	ASTM D-150, IEC 250	maximum	5,0	5,0	5,0	5,0	5,0	5,0
Dielectric strength	ASTM D-149, IEC 243	kV/mm @ 1,3 mm kV/mm @ 1,5 mm kV/mm @ 2,0 mm kV/mm @ 2,5 mm kV/mm @ 3,0 mm	18 15 12	13	13	11	22	15
Thermal								
Thermal Endurance	IEE 1-1969, IEC 216	minimum	105°C	105°C	105°C**	100°C	105°C	-
Accelerated aging for 168 hours	ISO 188	Tensile Strength, Mpa min	10	10	10	7,6	8	17
		Ultimate Elongation, min	300%	200%	300%	300%	100%	25%
		Aging Temp.	120°C	120°C	120°C	120°C	150°C	120°C
Chemical								
Flammability	ANSI C37.20	Pass	Pass	Pass	Pass			
Water absorption	ISO/R 62, procedure A	1% max after 14 days at 23°C	Pass	Pass	Pass	Pass	Pass	Pass
Low-temperature flexibility	ASTM D-2671, Procedure C	No cracking after 4 hours	Pass -40°C	Pass -40°C	Pass -40°C	Pass -40°C	Pass -40°C	Pass -40°C
Corrosion	Copper Mirror, ASTM D-2671, procedure B	Passed visual inspection after 16 hours	-	Pass 150°C	Pass 150°C	-	Pass 135°C	-
Physical								
Tensile strength	ASTM D-638, ISO 37	Mpa (minimum)	10 < 4mm 8 > 4mm	10	10	8	10	17
Ultimate elongation	ASTM D-638, ISO 37	% minimum	300	300	300	300	200	25

NOTE Blank spaces indicate that property was not measured during product qualification
Each product's voltage rating will be displayed with its selection information
*Properties measured on backing material only. HVBT has a 90°C maximum continuous operating temperature limit

TE Connectivity (NYSE: TEL) is a \$14 billion global technology leader. Our connectivity and sensor solutions are essential in today's increasingly connected world. We collaborate with engineers to transform their concepts into creations - redefining what's possible using intelligent, efficient and high-performing TE products and solutions proven in harsh environments. Our 80,000 people, including 7,500 design engineers, partner with customers in over 150 countries across a wide range of industries. We believe EVERY CONNECTION COUNTS - www.TE.com.

- Mining
- Nuclear power plants
- OEMs
- Overhead distribution
- Petrochemical plants
- Railways
- Street lighting
- Substations
- Transmission lines
- Underground distribution
- Windfarms
- Solar
- Hydro-electric

WHEREVER ELECTRICITY FLOWS, YOU'LL FIND TE ENERGY



te.com/energy

FOR MORE INFORMATION:

TE Technical Support Centers

France:	+ 33 380 583 212	PL, Warsaw + Baltics:	+ 48 224 576 753
Germany:	+ 49 896 089 903	CZ, Prague:	+ 42 0 272 011 105
UK:	+ 44 8 708 707 500	Sweden/Norway:	+ 46 850 725 057
Spain:	+ 34 916 630 400	Denmark:	+ 45 43 480 424
Middle East:	+ 971 4-2 117 000		

te.com/energy

© 2015 TE Connectivity Ltd. family of companies. All Rights Reserved. EPP-1924-5/15

Raychem, TE Connectivity and the TE connectivity (logo) are trademarks of the TE Connectivity Ltd. family of companies. Other logos, product and company names mentioned herein may be trademarks of their respective owners. While TE has made every reasonable effort to ensure the accuracy of the information in this brochure, TE does not guarantee that it is error-free, nor does TE make any other representation, warranty or guarantee that the information is accurate, correct, reliable or current. TE reserves the right to make any adjustments to the information contained herein at any time without notice. TE expressly disclaims all implied warranties regarding the information contained herein, including, but not limited to, any implied warranties of merchantability or fitness for a particular purpose. The dimensions in this brochure are for reference purposes only and are subject to change without notice. Specifications are subject to change without notice. Consult TE for the latest dimensions and design specifications.