

REVISIONS					
P	LTR	DESCRIPTION	DATE	DWN	APVD
	B2	REVISED PER ECR-24-219327	12SEP2024	RK	YK

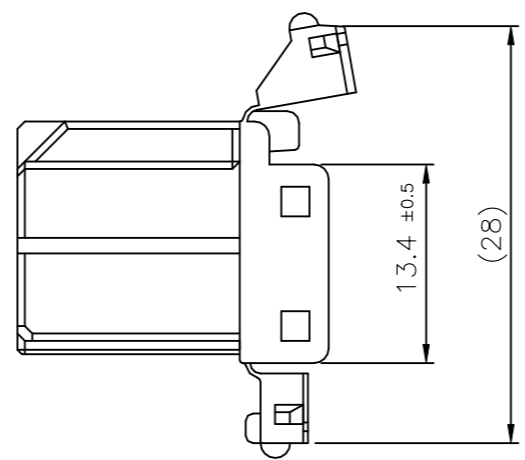
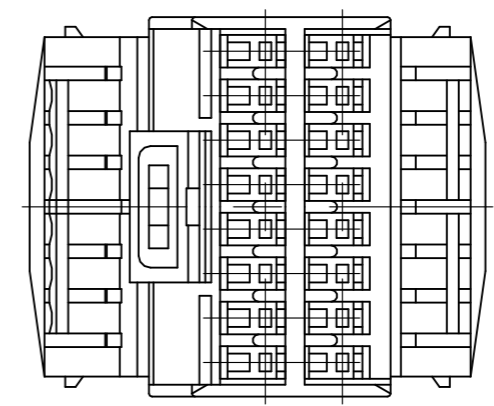
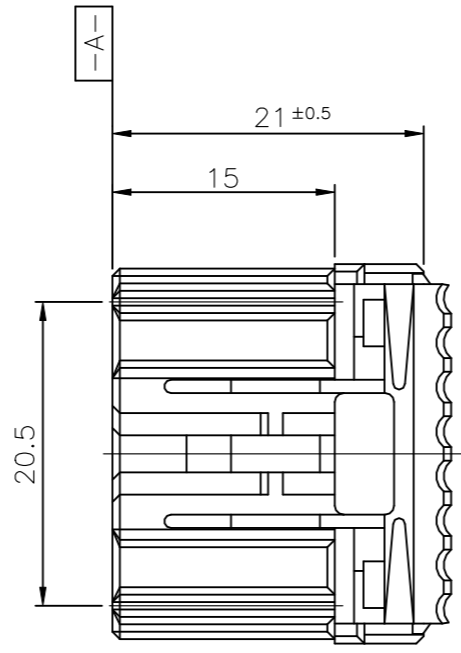
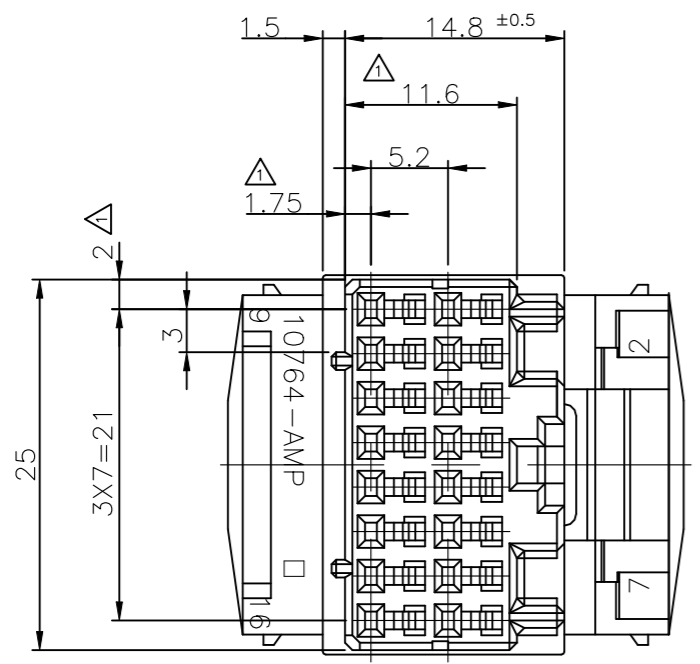

NOTES;

- ⚠ MUST BE KEPT BETWEEN -Z- AND 2mm.
- 2. THE MATING CAP HOUSING PART NUMBER, 174518
- 3. APPLIDE CONTACT PART NUMBER, 173716
- ⚠ APPLICABLE PRODUCT SPEC NO. 108-5280

	PBT	368134-7	YELLOW
	PBT	368134-6	GRAY
ⓑ	OBSELETE	368134-2	BLACK
	PBT	368134-1	NATURAL
	MATERIAL	PART NUMBER	COLOR

TOLERANCES UNLESS OTHERWISE SPECIFIED:

0 <XX<10	± 0.2
10 <XX<30	± 0.25
30 <XX	± 0.3
ANGLES	± 3°

THIS DRAWING IS A CONTROLLED DOCUMENT.	
DIMENSIONS: mm	TOLERANCES UNLESS OTHERWISE SPECIFIED:
	0 PLC ± -
	1 PLC ± -
	2 PLC ± -
	3 PLC ± -
	4 PLC ± -
	ANGLES ± -
MATERIAL SEE TABLE	FINISH SEE TABLE

DWN	HS BAE	-	<b>STE</b> TE Connectivity			
CHK	BM JANG	-				
APVD	CS LEE	-				
PRODUCT SPEC						
APPLICATION SPEC			NAME 040 16P REC HSG			
WEIGHT	-		SIZE	CAGE CODE	DRAWING NO	RESTRICTED TO
CUSTOMER DRAWING			A3	00779	C-368134	-
			SCALE	SHEET	REV	
			2:1	1 OF 1	B2	