

THIS DRAWING IS UNPUBLISHED. RELEASED FOR PUBLICATION 2011
 © COPYRIGHT 2011 BY Tyco Electronics Japan G.K. ALL RIGHTS RESERVED.

LOC	DIST	REVISIONS					
J	-	P	LTR	DESCRIPTION	DATE	DWN	APVD
		A		RELEASED	25OCT2016	T.G	N.Y

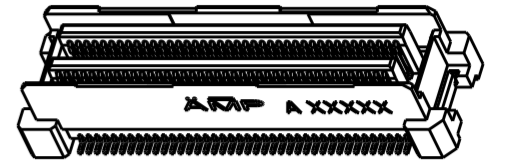

SCALE 2:1

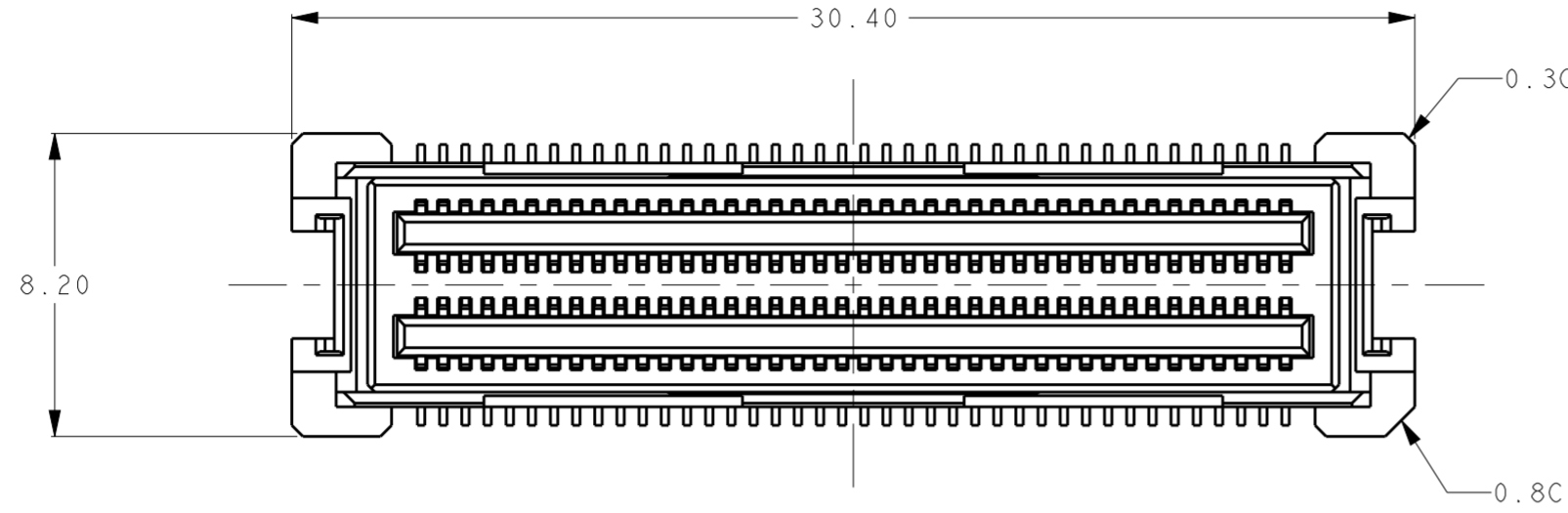
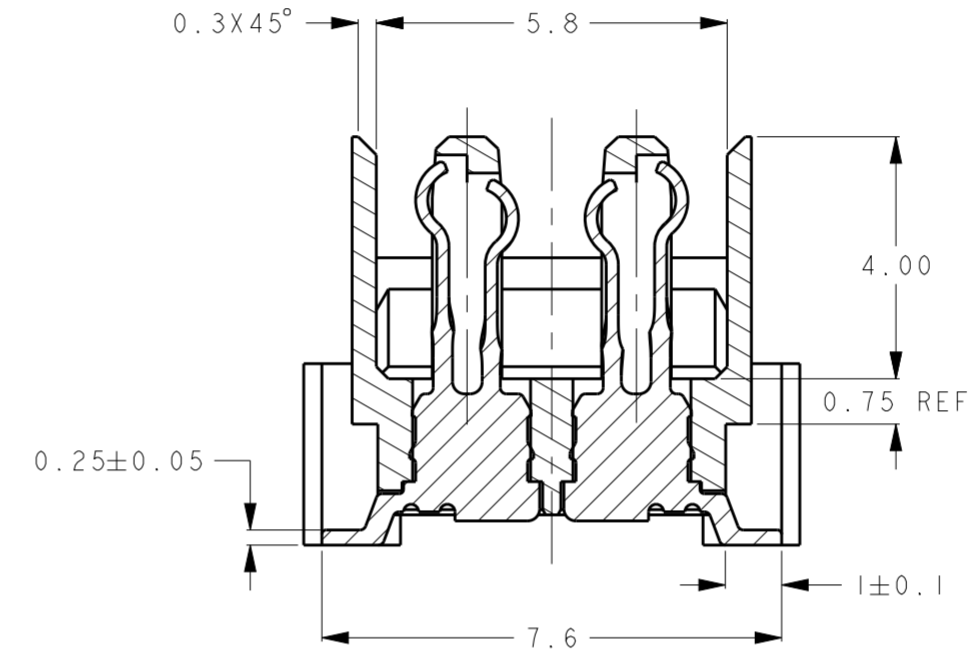
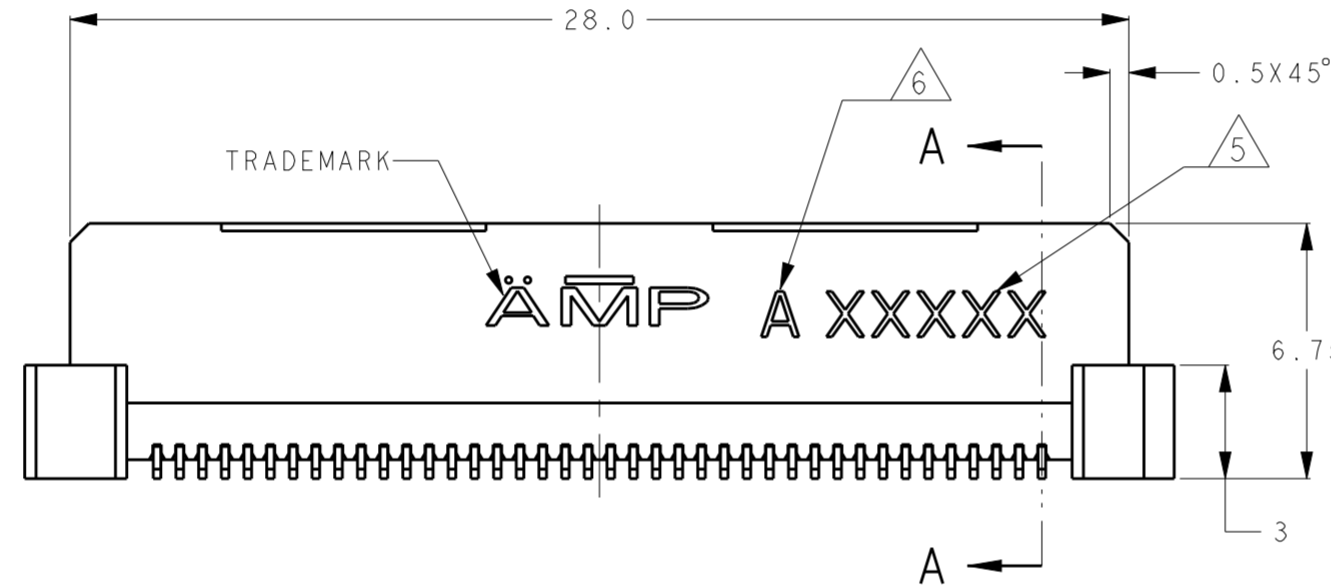
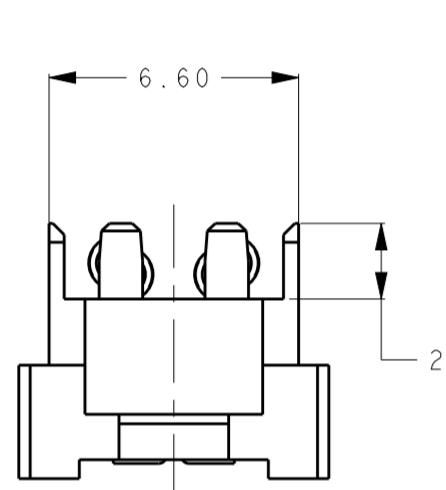

A - A
SCALE 8:1

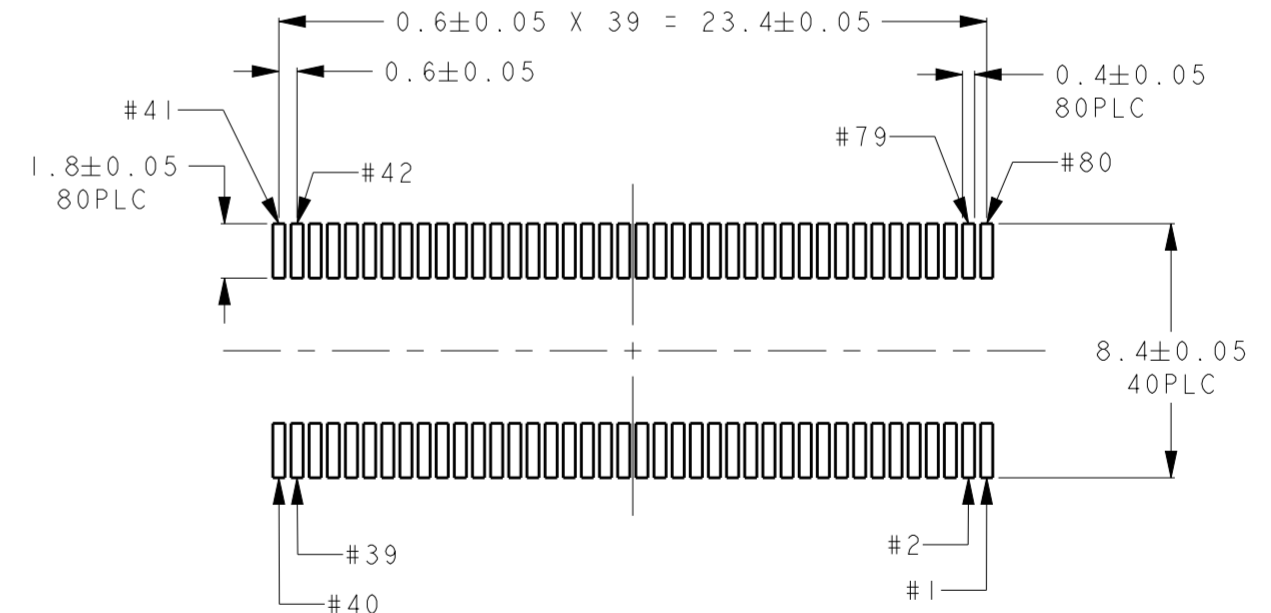
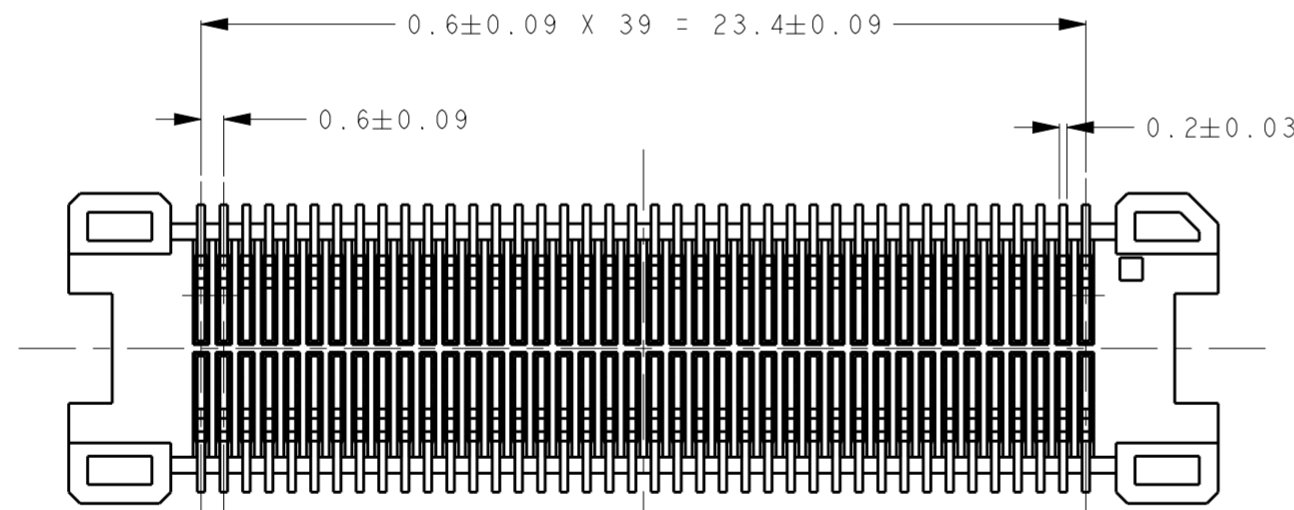

推奨基板取付寸法
RECOMMENDED PCB LAYOUT

- 1 MATERIAL : HOUSING; LCP
; CONTACT; COPPER ALLOY
- 2 FINISH : UNDER Ni PL. 0.8μmMIN
CONTACT AREA: Au PL. 0.1μmMIN
SOLDERING AREA: Au FLASH
- 3. COPLANARITY 0.1MAX.
- 4. SHOULD BE PUT 45 CONNECTORS IN HARD TRAY. (SEE SHEET 2)
- 5 MARKING THE DATE CODE IN THE SHOWN AREA.
MARK ON EITHER FRONT SIDE OR BACK SIDE.
- 6 IDENTIFIER FOR 0.1μm GOLD PLATING

- 1 材料 : ハウジング : 液晶ポリマー
コンタクト : 銅合金
- 2 仕上げ : 全面ニッケル下地 0.8μmMIN
接点部 金メッキ 0.1μmMIN
半田付部 金フラッシュ
- 3. コプランナリティー 0.1MAX
- 4. 梱包形態は、ハードトレイに45個入りとする。(シート2参照)
- 5 デートコードの印字箇所
ただし、ハウジングの表裏は問わない。
- 6 金メッキ 0.1μm製品の識別記号

2305218-1
PART NO

THIS DRAWING IS A CONTROLLED DOCUMENT.		DWN T. GOIO 28 JUL 2016	TE Connectivity	
DIMENSIONS: 単位: 概 mm		CHK Y. OKADA 28 JUL 2016		
TOLERANCES UNLESS OTHERWISE SPECIFIED: 一般公差 0 PLC ±0.3 1 PLC ±0.25 2 PLC ±0.2 3 PLC ± 4 PLC ± ANGLES ±3°		APVD N. YAMASAKI 28 JUL 2016	NAME HDR ASSEMBLY 6.75mm HEIGHT 0.6mm PITCH 80P MICRO STACK CONNECTOR	
MATERIAL 材料		PRODUCT SPEC 108-140125-1	SIZE A2	CAGE CODE 0779
FINISH 仕上		APPLICATION SPEC	DRAWING NO C-2305218	RESTRICTED TO -
1		WEIGHT 1.66g	SCALE 5:1	
2		CUSTOMER DRAWING		SHEET 1 OF 2 REV A

THIS DRAWING IS UNPUBLISHED. RELEASED FOR PUBLICATION 2011
 © COPYRIGHT 2011 BY Tyco Electronics Japan G.K. ALL RIGHTS RESERVED.

LOC	DIST	REVISIONS			
P	LTR	DESCRIPTION	DATE	DWN	APVD
-	-	SEE SHEET 1	-	-	-

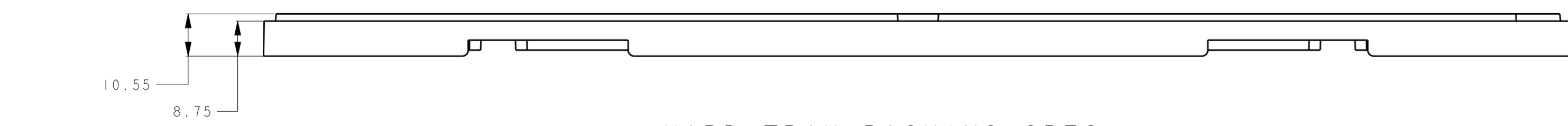
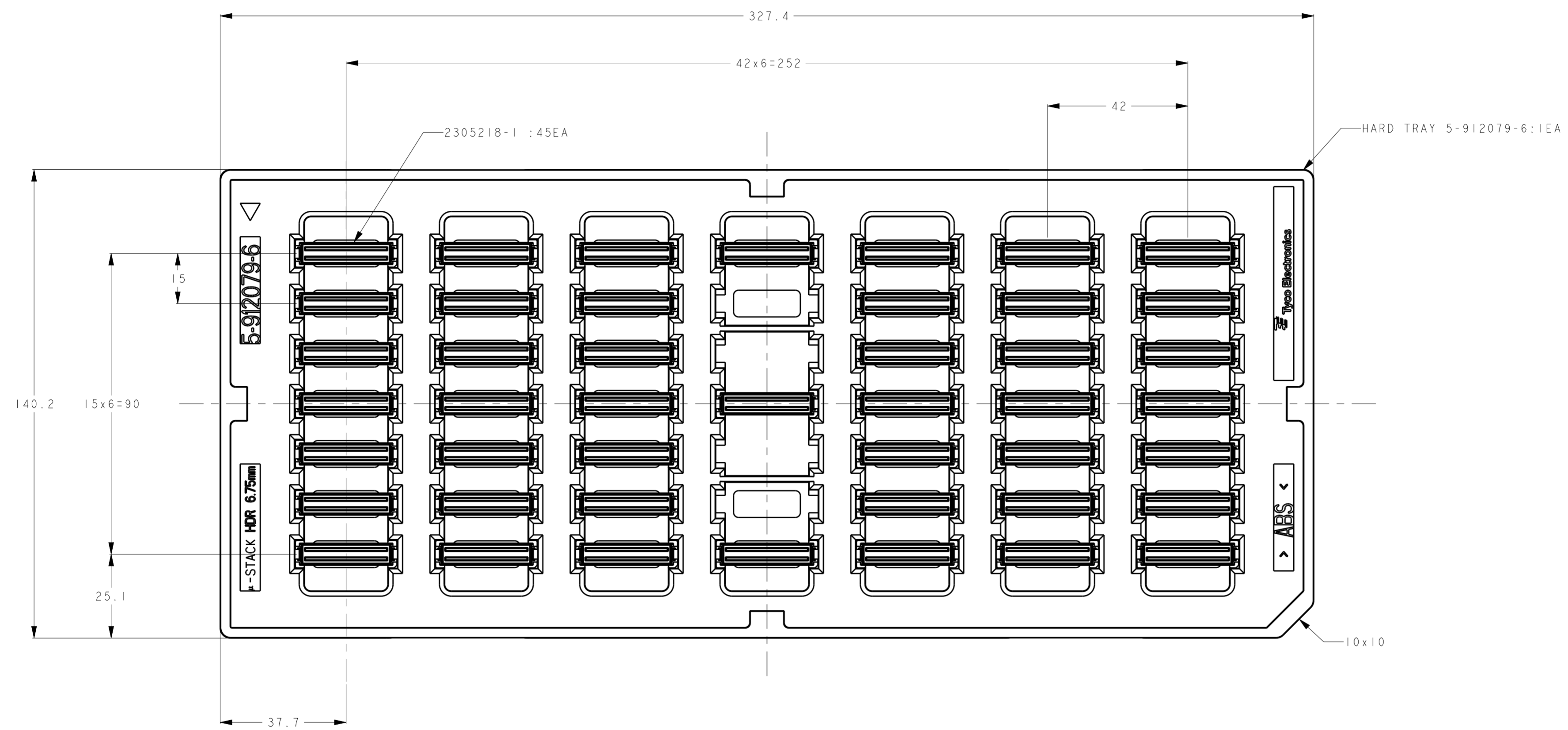

HARD TRAY PACKING SPEC

45	BLACK
CONN QTY	HARD TRAY COLOR

THIS DRAWING IS A CONTROLLED DOCUMENT.		DWN I. GOIO 28 JUL 2016	TE Connectivity
DIMENSIONS: 単位: mm		CHK Y. OKADA 28 JUL 2016	
TOLERANCES UNLESS OTHERWISE SPECIFIED: □ 0-PLC ± 1 □ 1-PLC ± 0.3 □ 2-PLC ± 0.25 □ 3-PLC ± 0.2 □ 4-PLC ± ANGLES ± 3° FINISH		APVD N. YAMASAKI 28 JUL 2016	
MATERIAL		PRODUCT SPEC 108-140125-1 APPLICATION SPEC WEIGHT 1.66g	
NAME HDR ASSEMBLY 6.75mm HEIGHT 0.6mm PITCH 80P MICRO STACK CONNECTOR		SIZE A20779	RESTRICTED TO
CUSTOMER DRAWING		DRAWING NO C-2305218	SCALE 1:1 SHEET 2 OF 2 REV A