

THIS DRAWING IS UNPUBLISHED. RELEASED FOR PUBLICATION 20
 © COPYRIGHT 20 BY - ALL RIGHTS RESERVED.

LOC	DIST	REVISIONS					
GE	00	P	LTR	DESCRIPTION	DATE	DWN	APVD
			A	RELEASED PER ECO-13-009520	07JUN2013	DD	RB

1. MATERIAL: SILICONE RUBBER, COLOR: SEE TABLE
2. FOR USE WITH WIRE INSULATION O.D. RANGE OF 1.30mm TO 2.54mm.

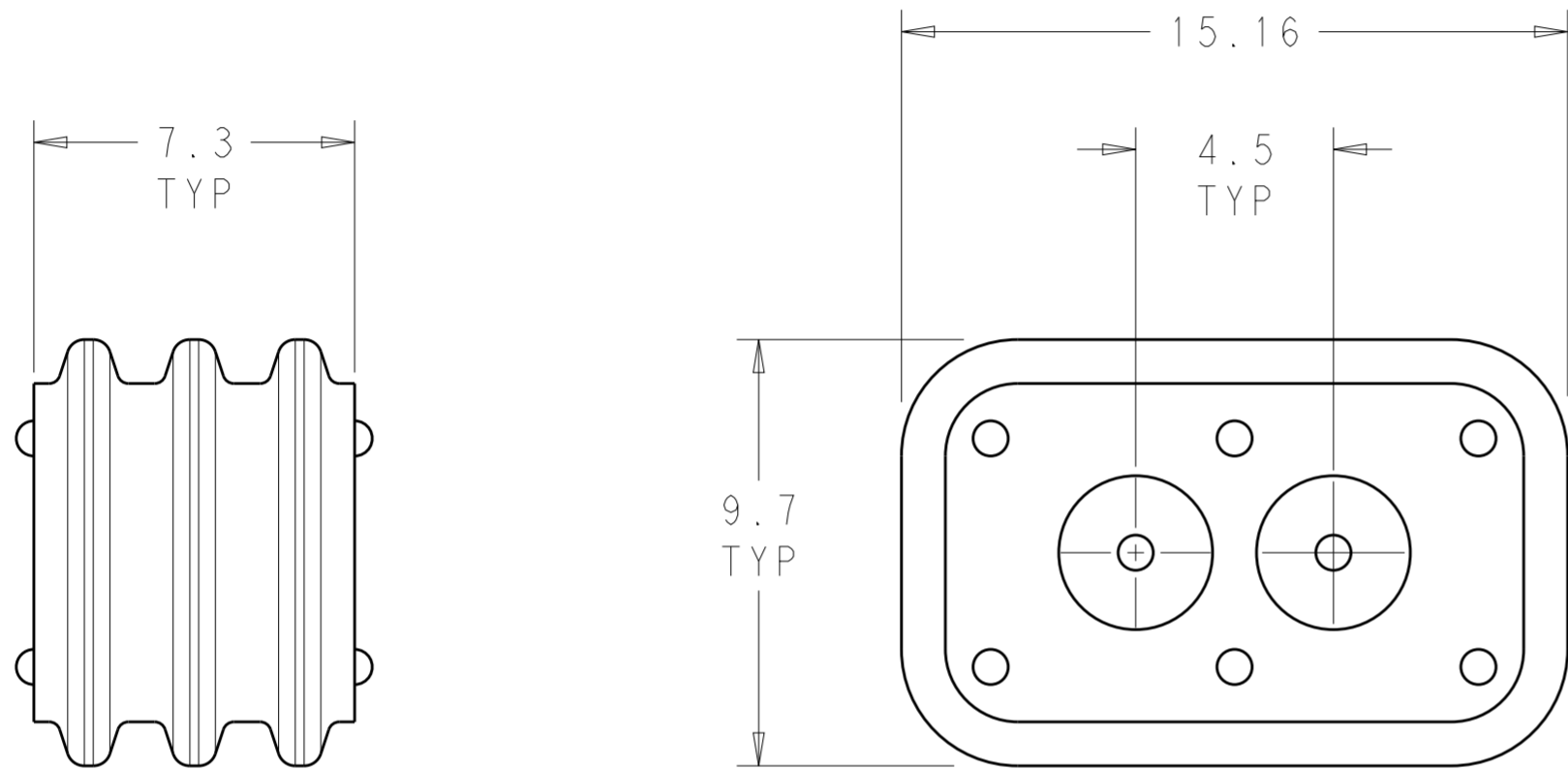

2203728-1

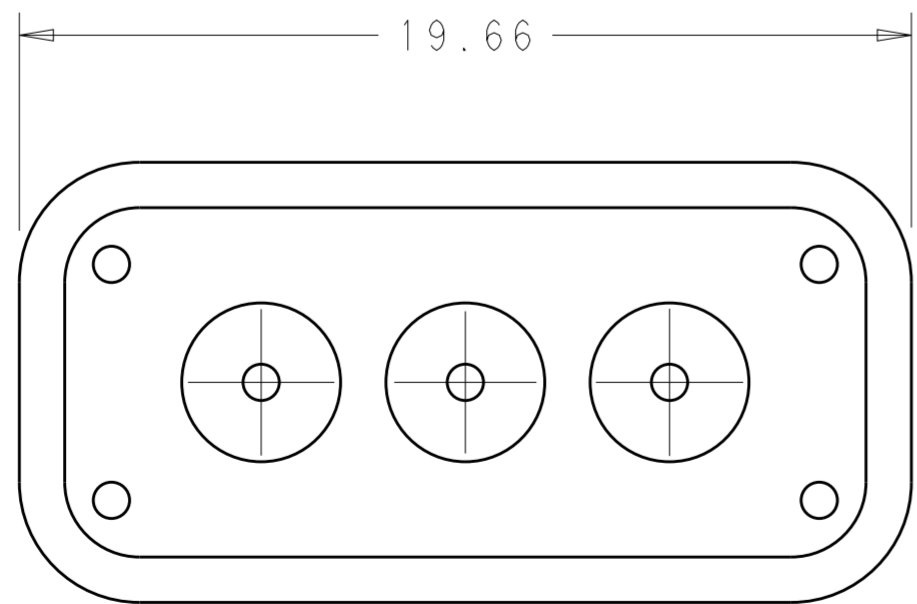

2203728-2

CAP ASSEMBLY	PLUG ASSEMBLY	DUROMETER	COLOR/CODE	DESCRIPTION	PART NUMBER
776535-1, -2, -3, -4	776523-1, -2, -3, -4	30	RUST	3 POSN	2203728-2
776534-1, -2, -3, -4	776522-1, -2, -3, -4	30	LIGHT GRAY	2 POSN	2203728-1

WHERE USED

THIS DRAWING IS A CONTROLLED DOCUMENT.		DWN R. VESTAL 30APR2013	STE TE Connectivity	
		CHK R. BALTER 30APR2013		
		APVD R. BALTER 30APR2013	NAME	
DIMENSIONS: mm		PRODUCT SPEC 108-2184	WIRE SEAL, SINGLE ROW, REDUCED DIAMETER, AMPSEAL 16	
TOLERANCES UNLESS OTHERWISE SPECIFIED: 0 PLC ± 1 PLC ±0.2 2 PLC ±0.20 3 PLC ± 4 PLC ±		APPLICATION SPEC 114-13065	SIZE	RESTRICTED TO
MATERIAL SEE NOTE		WEIGHT -	CAGE CODE A200779	
FINISH SEE NOTE		CUSTOMER DRAWING	DRAWING NO C-2203728	REV A
		SCALE 6:1	SHEET 1 OF 1	