

REVISIONS

P	LTR	DESCRIPTION	DATE	DWN	APVD
	B	NEW RELEASE	24-JAN-11	PT	St.P
	B1	REVISED PER ECR-20-015376	28OCT2020	SR	AP
	B2	NEW PART 1-1630184-4 ADDED	22MAR2022	AJ	AP

FOR FURTHER INFORMATION SEE DATA SHEET FOR HIGH POWER CAPACITOR DISCHARGE RESISTORS YP SERIES

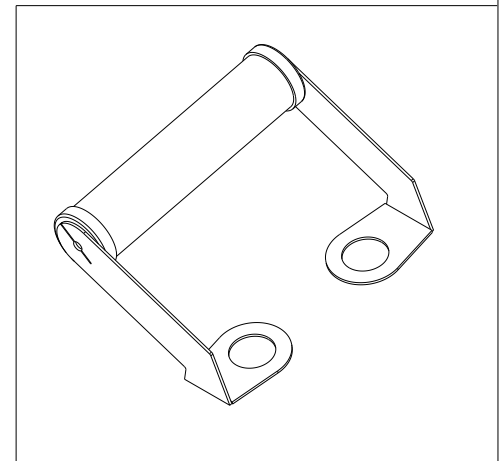
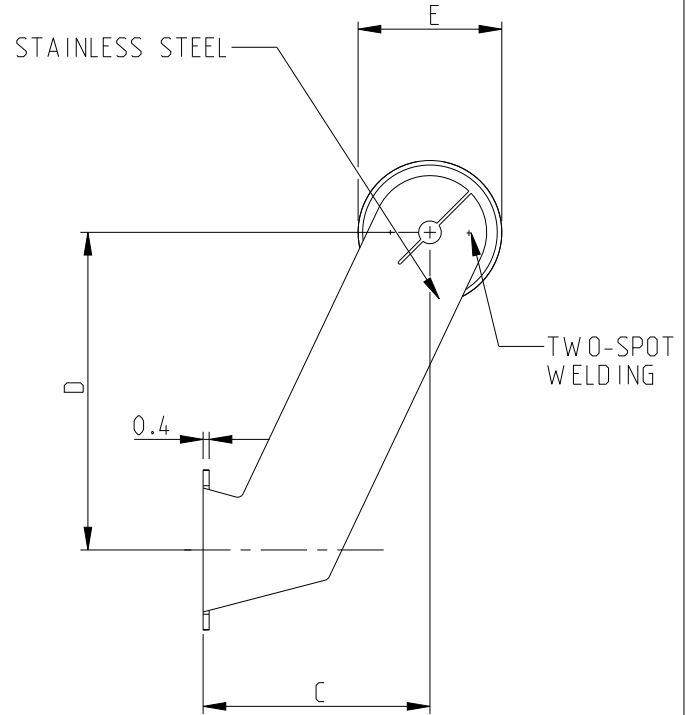
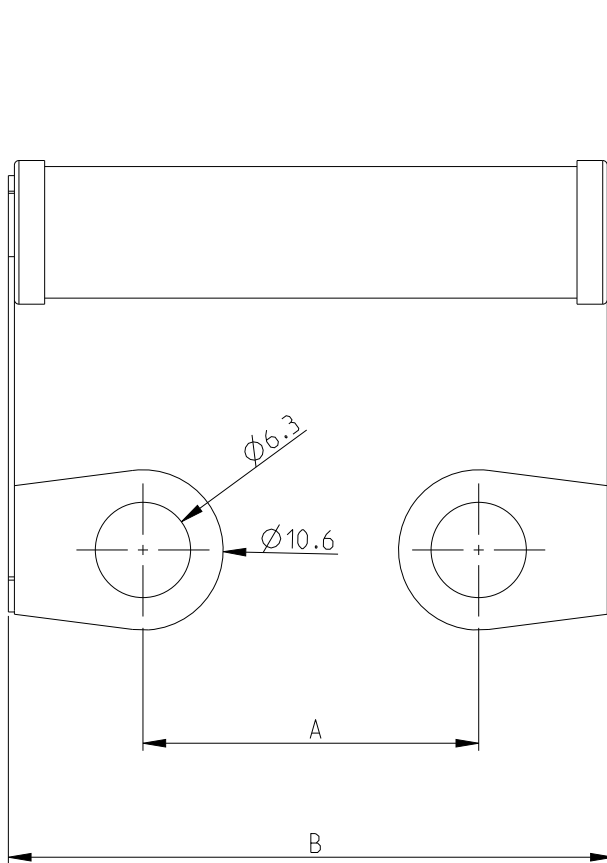

DIMENSIONS

	A ±1mm	B max.	C ±1mm	D ±1mm	E ±1mm
YP8	22.2	40	15	21	9.5
YP10	31.8	50	15	21	9.5

© 2020 TE Connectivity. All Rights Reserved.

DIMENSIONS: mm	DWN T.PARUSURAM	24-JAN-2011	MATERIAL	-	FINISH	-
	CHK ALLAN.P	24-JAN-2011				
TOLERANCES UNLESS OTHERWISE SPECIFIED:	APVD STEPHEN.P	24-JAN-2011				
	0 PLC ±0.2	PRODUCT SPEC	-	SIZE		RESTRICTED TO
1 PLC ±0.1	APPLICATION SPEC	-	A 4	CAGE CODE	DRAWING NO	
2 PLC ±				00779	©=1630184	
3 PLC ±						
4 PLC ±						
ANGLES 5°	WEIGHT	-	CUSTOMER DRAWING			
			SCALE	3:1	SHEET	1 OF 2
					REV	B2

REVISIONS					
P	LTR	DESCRIPTION	DATE	DWN	APVD
	-	SEE SHEET 1	-	-	-

PART SCHEDULE

TCPN	PART DESCRIPTION	ALIAS	TYPE	PART STATUS	COMMENT
1630184-1	YP10 10K 5%	YP1010KJ	YP10	Production	Standard
1630184-2	YP10 10K 5%	1630184-2	YP10	Discontinued	Use 1630184-1
1630184-3	YP10 18K 5%	YP1018KJ	YP10	Production	Standard
1630184-4	YP10 18K 5%	1630184-4	YP10	Discontinued	Use 1630184-3
1630184-5	YP10 27K 5%	YP1027KJ	YP10	Production	Standard
1630184-6	YP10 27K 5%	1630184-6	YP10	Discontinued	Use 1630184-5
1630184-7	YP10 2K0 5%	YP102K0J	YP10	Production	Standard
1630184-8	YP10 2K0 5%	1630184-8	YP10	Discontinued	Use 1630184-7
1630184-9	YP10 47K 5%	YP1047KJ	YP10	Production	Standard
1-1630184-0	YP10 47K 5%	1-1630184-0	YP10	Superseded	Use 1630184-9
1-1630184-1	YP10 33K 5%	YP1033KJ	YP10	Discontinued	Standard
1-1630184-2	YP8 18K 5%	YP818KJ	YP8	Production	Standard
1-1630184-3	YP10 10K 5%	YP1010KJV	YP10	Production	Special - MOQ 2000
1-1630184-4	YP10 120K 5%	YP10120KJ	YP10	Production	Standard

© 2020 TE Connectivity. All Rights Reserved.

DIMENSIONS: mm	DWN T.PARUSURAM	24-JAN-2011	MATERIAL	-	FINISH	-
	CHK ALLAN.P	24-JAN-2011				
TOLERANCES UNLESS OTHERWISE SPECIFIED:	APVD STEPHEN.P	24-JAN-2011				
	PRODUCT SPEC	-	NAME	HIGH POWER CAPACITOR DISCHARGE RESISTORS YP SERIES		
	APPLICATION SPEC	-	SIZE	CAGE CODE	DRAWING NO	RESTRICTED TO
0 PLC ±0.2 1 PLC ±0.1 2 PLC ± 3 PLC ± 4 PLC ± ANGLES ±5°	WEIGHT	-	A 4	00779	©=1630184	
CUSTOMER DRAWING			SCALE	3:1	SHEET	2 OF 2
					REV	B2