

## 3-WAY CAM LOCKING CONNECTOR NG1 6.35 mm

**3-WAY CAM LOCKING CONNECTOR 6.35 mm**

**CONTENTS**

**- 6.35 mm 3-WAY CONNECTOR**

PARTS LIST

**- UTILISATION OF 6.35 mm 3-WAY CONNECTOR CH/TH**

3-WAY CLIP-HOLDER PACKAGING  
3-WAY HOLDER PACKAGING  
CLIP HOLDER COMPONENT MARKINGS  
TAB HOLDER COMPONENT MARKINGS  
CLIP HOLDER ASSEMBLY SPACE REQUIREMENT  
TAB HOLDER ASSEMBLY SPACE REQUIREMENT  
CLIP HOLDER - WIRING (1)  
CHECK CONTACTS PRESENT - CLIP HOLDER  
CLIP HOLDER - WIRING (2)  
TAB HOLDER - WIRING (1)  
CHECK CONTACTS PRESENT - TAB HOLDER  
TAB HOLDER - WIRING (2)  
CLIP HOLDER - TAB HOLDER  
CLIP HOLDER - TAB HOLDER COUPLING

**- DISASSEMBLY OF 6.35 mm 3-WAY CONNECTOR**

CLIP HOLDER - TAB HOLDER

**- DISASSEMBLY AND REPAIR OF 6.35 mm 3-WAY CONNECTOR**

CLIP HOLDER - WIRING  
TAB HOLDER - WIRING

**APPENDIX – WIRING**

CLIP HOLDER AND TAB HOLDER

**CONNECTOR ASSEMBLY TRACEABILITY**

CLIP HOLDER - TAB HOLDER

**6.35 mm 3-WAY CONNECTOR****PARTS LIST****PRONER-COMATEL, TYCO and CUSTOMER PRODUCT PART NUMBERS**

<b>PART</b>	<b>COLOUR</b>	<b>PRONER- COMATEL P/N</b>	<b>TYCO P/N</b>	<b>PSA P/N</b>
CLIP HOLDER ASSEMBLY	BLACK	P80 103 89 746 02	1544225-1	See drawing 2304E500
	BLUE	P80 103 89 746 04	1544225-2	
	GREEN	P80 103 89 746 08	1544225-3	
TAB HOLDER ASSEMBLY	BLACK	P80 103 89 736 02	1544226-1	See drawing 2304E501
	BLUE	P80 103 89 736 04	1544226-2	
	GREEN	P80 103 89 736 08	1544226-3	

**PRONER-COMATEL, TYCO and CUSTOMER CONTACT PART NUMBERS**

<b>PART</b>	<b>SIZE</b>	<b>PRONER- COMATEL P/N</b>	<b>TYCO P/N</b>	<b>PSA P/N</b>
6.35 mm CLIP NG1	3 to 5 mm <sup>2</sup>	P79 101 79 855	1544133-1	See drwg. 0958C001
6.35 mm TAB NG1	3 to 5 mm <sup>2</sup>	P30 101 30 854	1544218-1	See drwg. 2252C001

UTILISATION OF 6.35 mm 3-WAY CONNECTOR CH/TH

3-WAY CLIP HOLDER PACKAGING

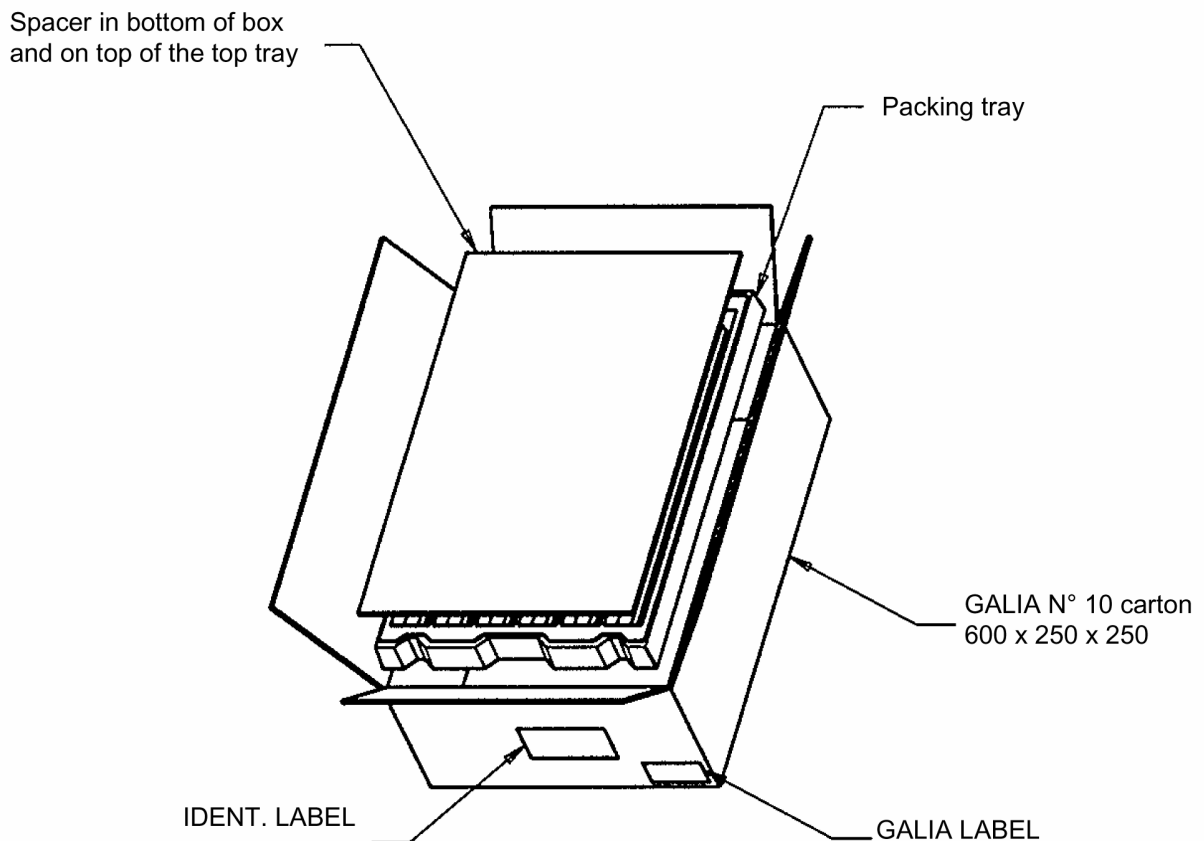

**PACKAGE**

TRAYS IN GALIA N° 10 CARTON

**IMPORTANT**

- THE PARTS SHOULD ONLY BE REMOVED FROM THE PACKAGES WHEN THE CLIPS ARE TO BE ASSEMBLED IN THE CLIP HOLDERS.
- THE TRAYS MUST BE REMOVED FROM THE CARTON ONE BY ONE.
- THE PARTS MUST BE REMOVED FROM THE TRAYS ONE BY ONE.

UTILISATION OF 6.35 mm 3-WAY CONNECTOR CH/TH

3-WAY TAB HOLDER PACKAGING

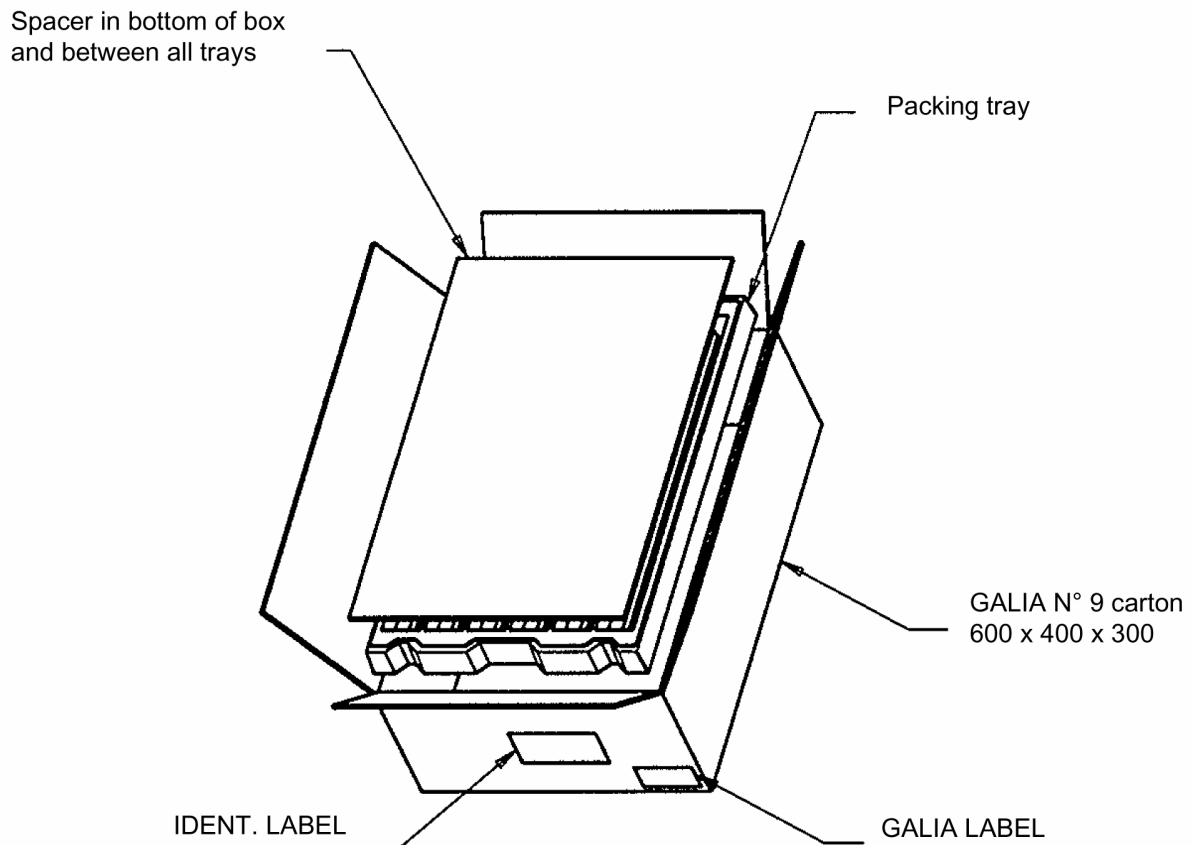

**PACKAGE**

TRAYS IN GALIA N° 9 CARTON

**IMPORTANT**

- THE PARTS SHOULD ONLY BE REMOVED FROM THE PACKAGES WHEN THE TABS ARE TO BE ASSEMBLED IN THE TAB HOLDERS.
- THE TRAYS MUST BE REMOVED FROM THE CARTON ONE BY ONE.
- THE PARTS MUST BE REMOVED FROM THE TRAYS ONE BY ONE.

UTILISATION OF 6.35 mm 3-WAY CONNECTOR CH/TH

CLIP HOLDER COMPONENT MARKINGS

CLIP HOLDER

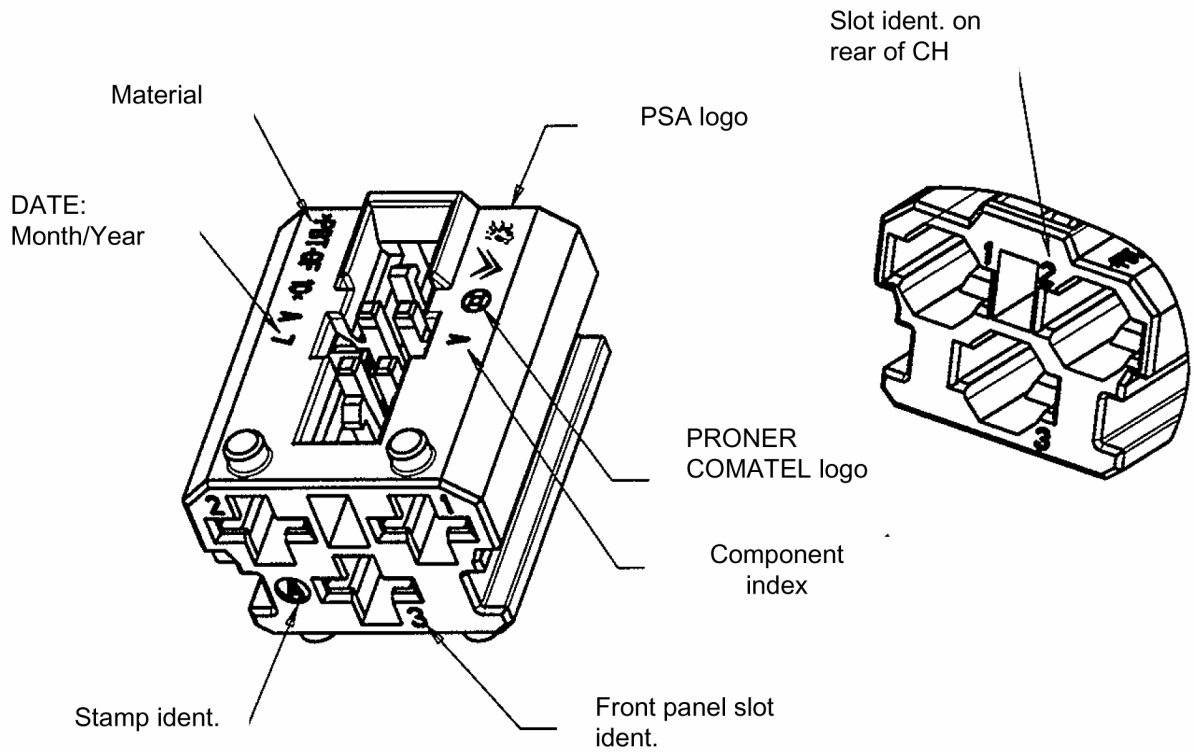

SECONDARY LATCH

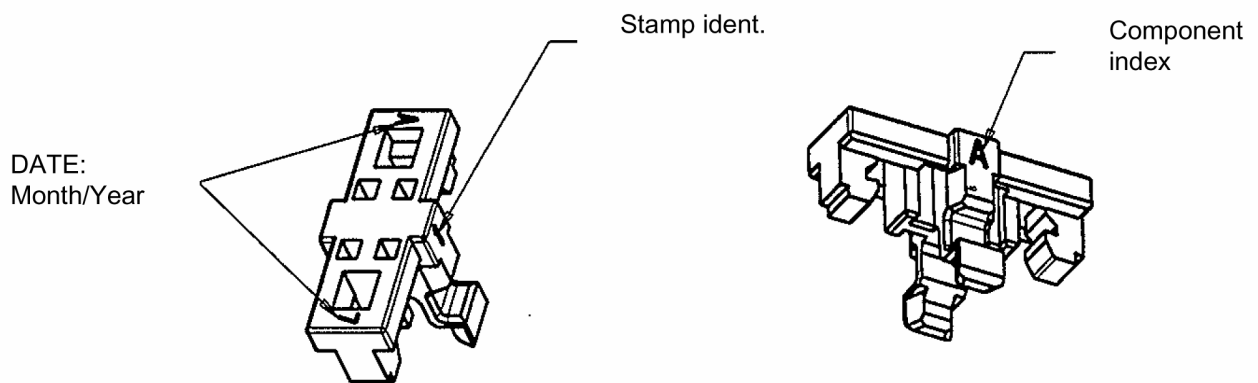

UTILISATION OF 6.35 mm 3-WAY CONNECTOR CH/TH

TAB HOLDER COMPONENT MARKINGS

TAB HOLDER

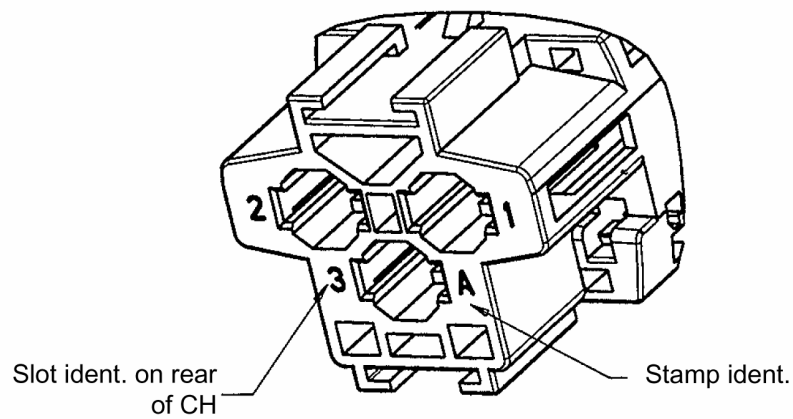
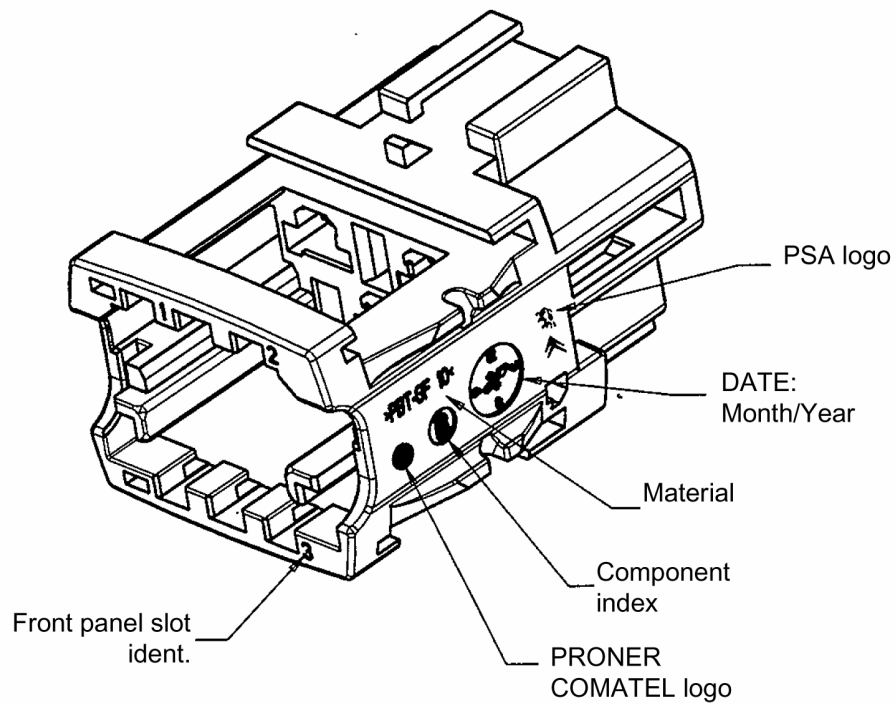

UTILISATION OF 6.35 mm 3-WAY CONNECTOR CH/TH

TAB HOLDER COMPONENT MARKINGS

**DETECTION GRID**

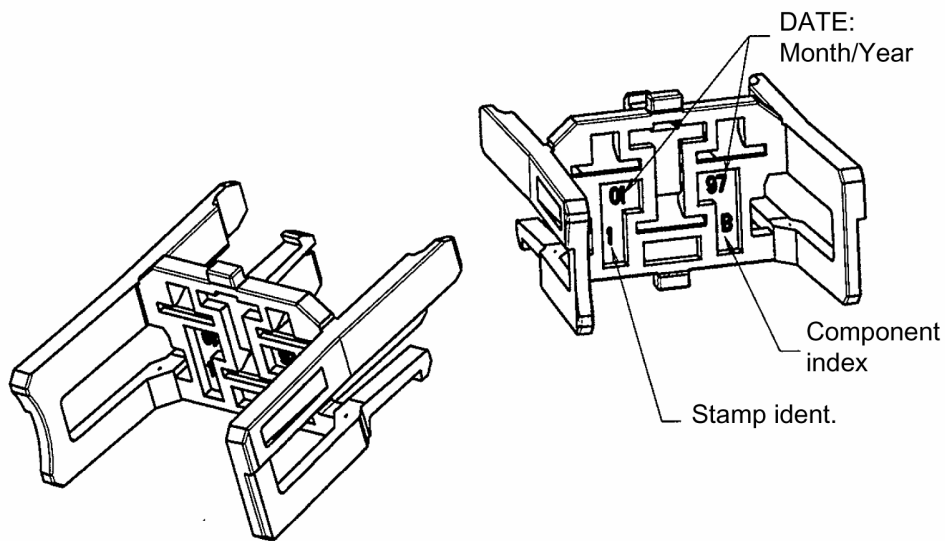

**CAM LOCKING**

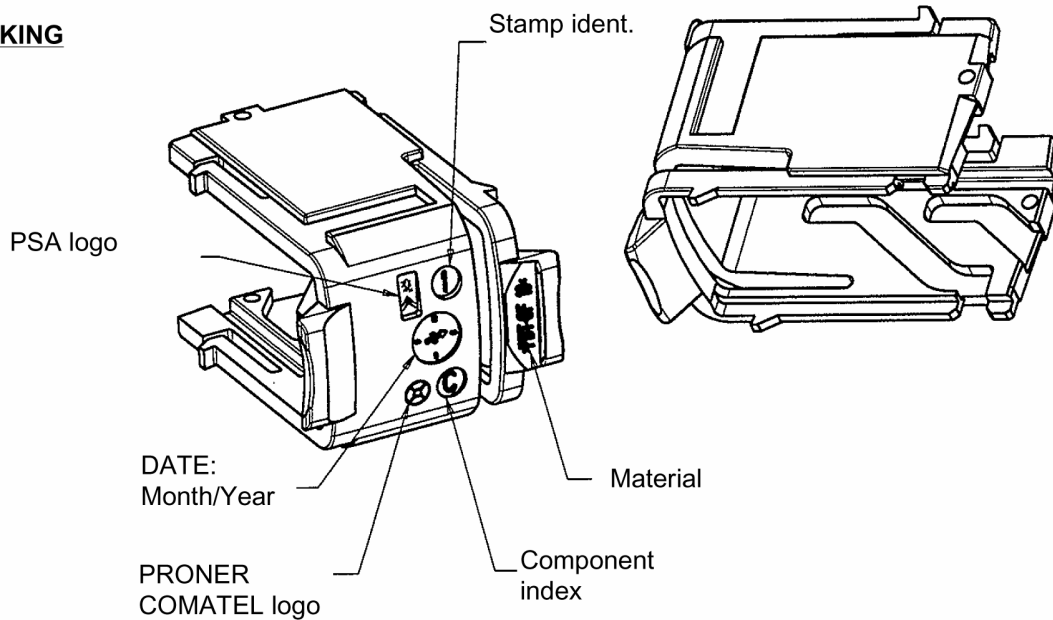



UTILISATION OF 6.35 mm 3-WAY CONNECTOR CH/TH

CLIP HOLDER ASSEMBLY DIMENSIONS

DELIVERY POSITION

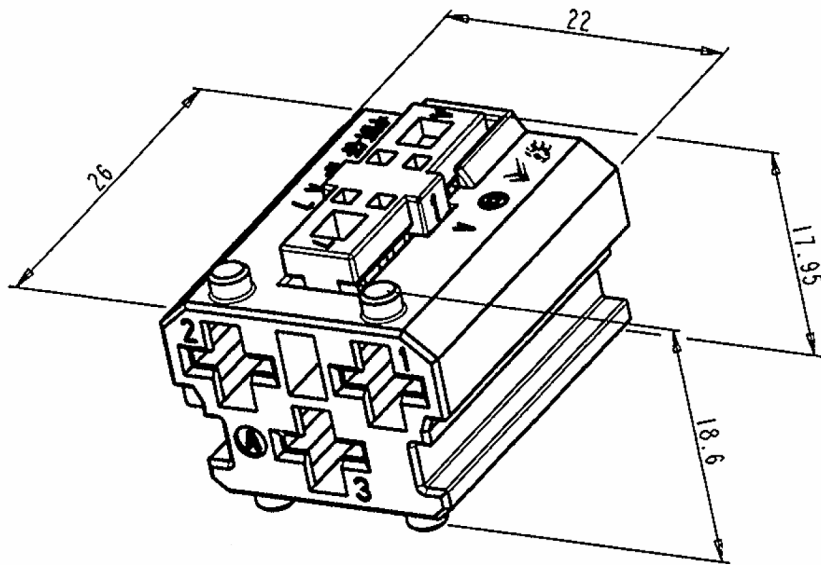

All dimensions are given as an approximate guide

CLOSED POSITION

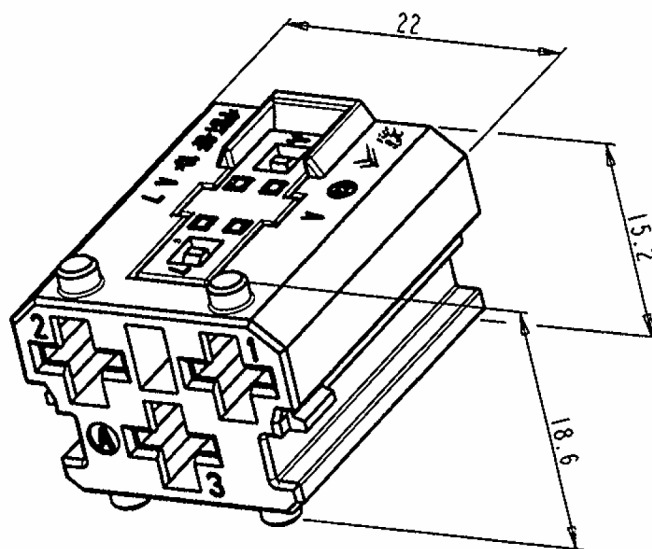

UTILISATION OF 6.35 mm 3-WAY CONNECTOR CH/TH

TAB HOLDER ASSEMBLY DIMENSIONS

DELIVERY POSITION

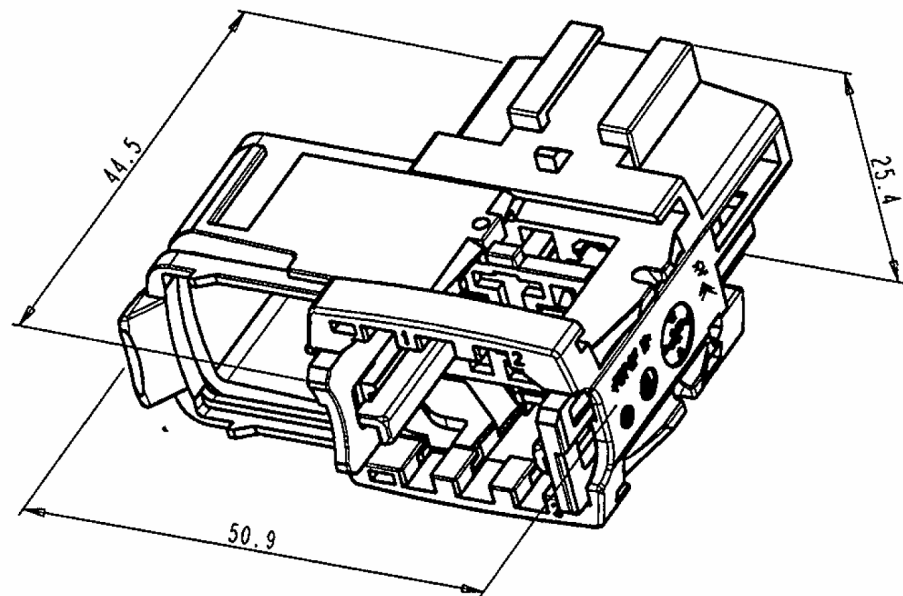

All dimensions are given as an approximate guide

CLOSED POSITION

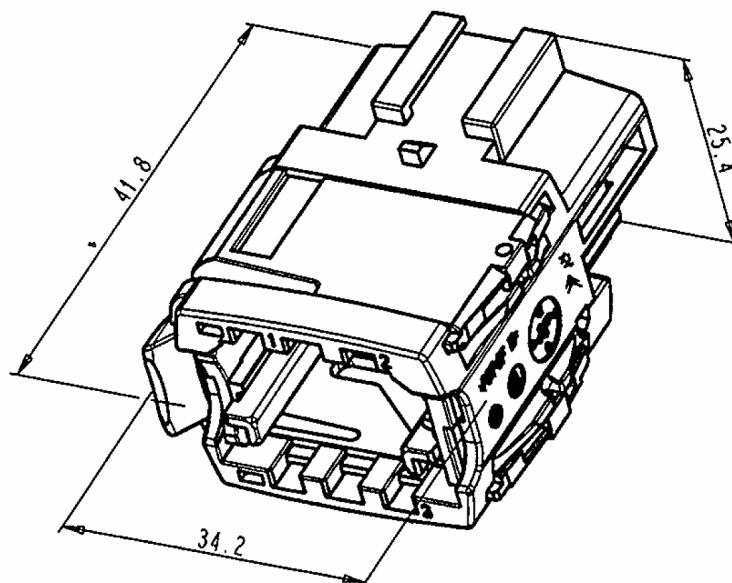

UTILISATION OF 6.35 mm 3-WAY CONNECTOR CH/TH

CLIP HOLDER - WIRING (1)

VIEW 1

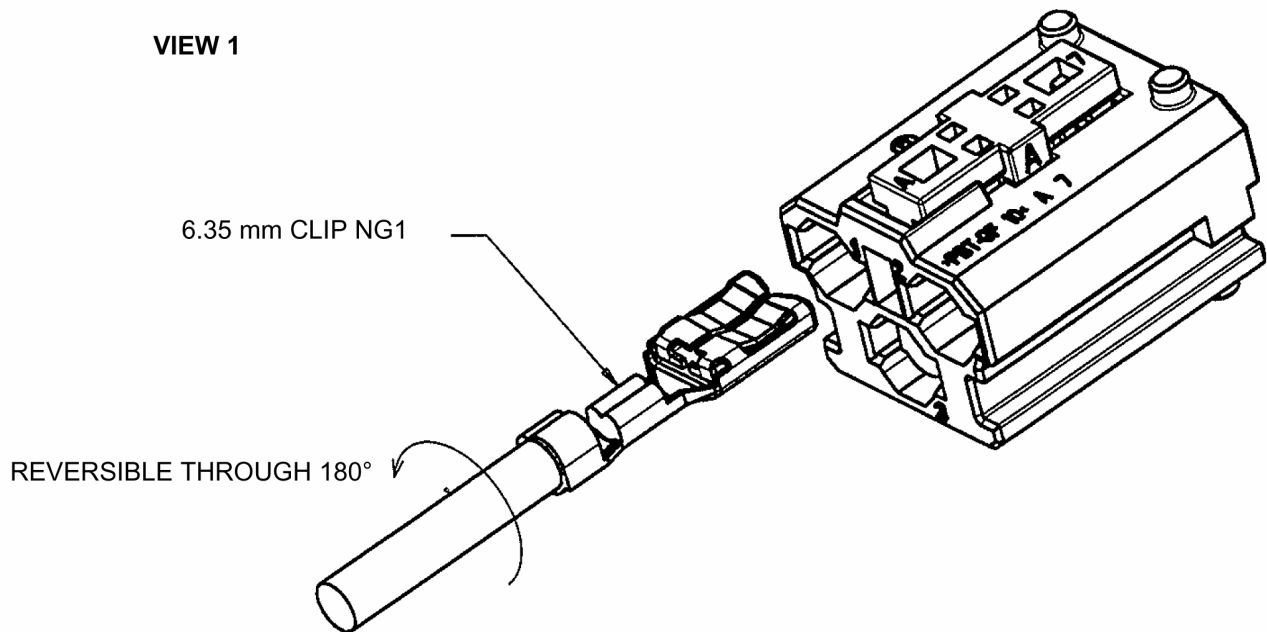

- PRESENT THE CLIP IN FRONT OF A SLOT, ON THE REAR OF THE CLIP HOLDER, WITH SECONDARY LATCH IN PRE-ASSEMBLED POSITION (VIEW 1)
- NOTE THAT THE CLIP IS REVERSIBLE THROUGH 180°
- THEN INSERT ALONG F FULLY INTO THE SLOT (VIEW 2)

VIEW 2

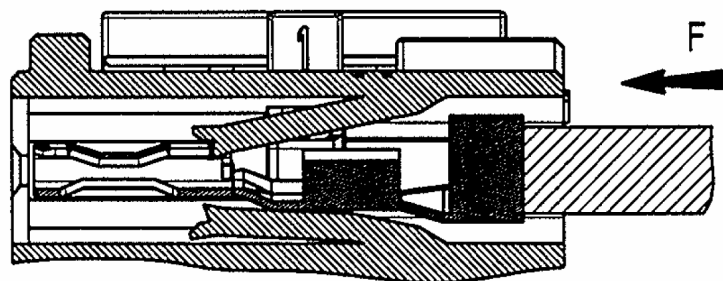

- IF THE SECONDARY LATCH IS IN THE CLOSED POSITION, THE CLIP CANNOT BE INSERTED
- CONTACT INSERTION FORCES, SL OPEN AND SL CLOSED, ARE GIVEN IN PSA SPECIFICATION N° 9630603499

UTILISATION OF 6.35 mm 3-WAY CONNECTOR CH/TH

CHECK CONTACT PRESENCE IN CLIP HOLDER

CONTACT PRESENCE CHECKED HERE

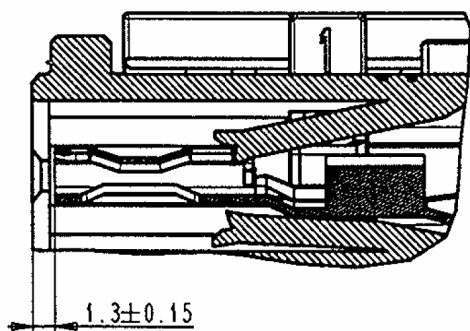
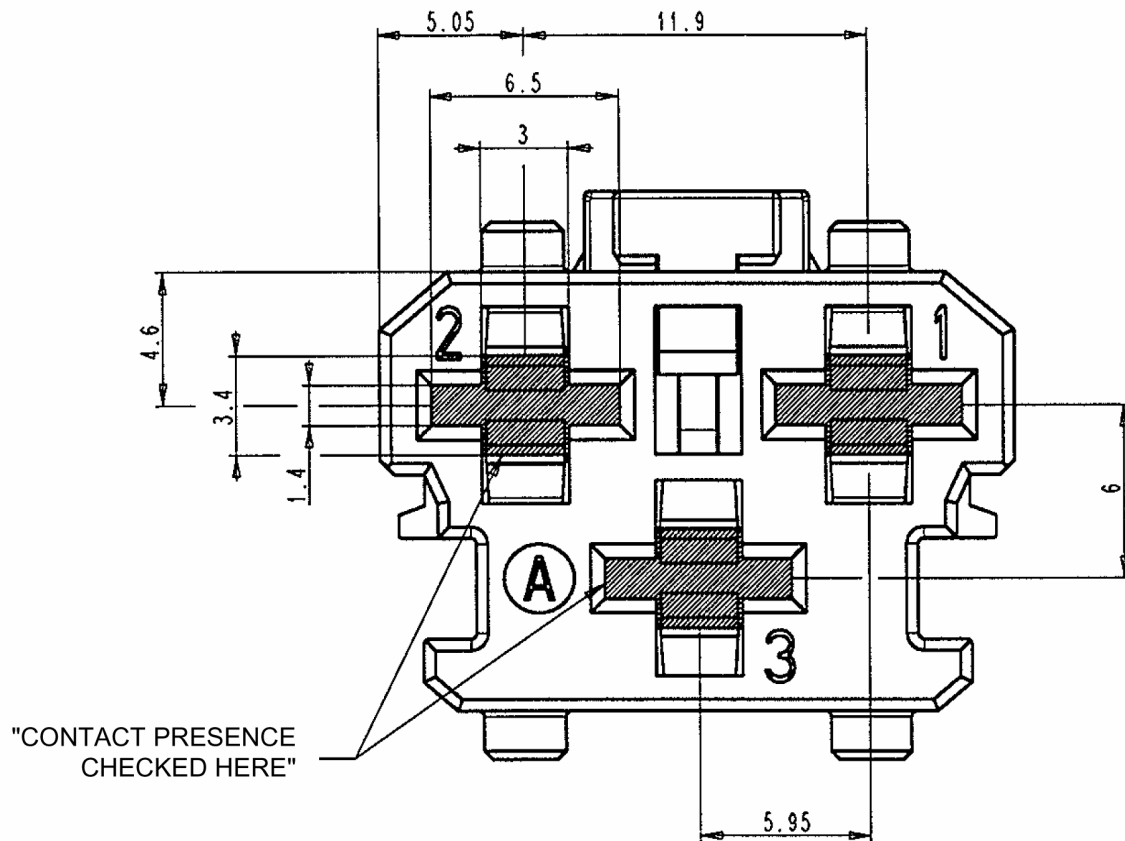

- CONTACT "PRESENCE IS CHECKED AFTER INSERTION AND LOCKING OF ALL CLIPS IN THE CLIP HOLDER, AND BEFORE CLOSING THE SECONDARY LATCH

UTILISATION OF 6.35 mm 3-WAY CONNECTOR CH/TH

CLIP HOLDER - WIRING (2)

WHEN ALL CLIPS HAVE BEEN INSERTED IN THE CLIP HOLDER, CLOSE THE SECONDARY LATCH BY PUSHING ALONG F1 (VIEW 1)

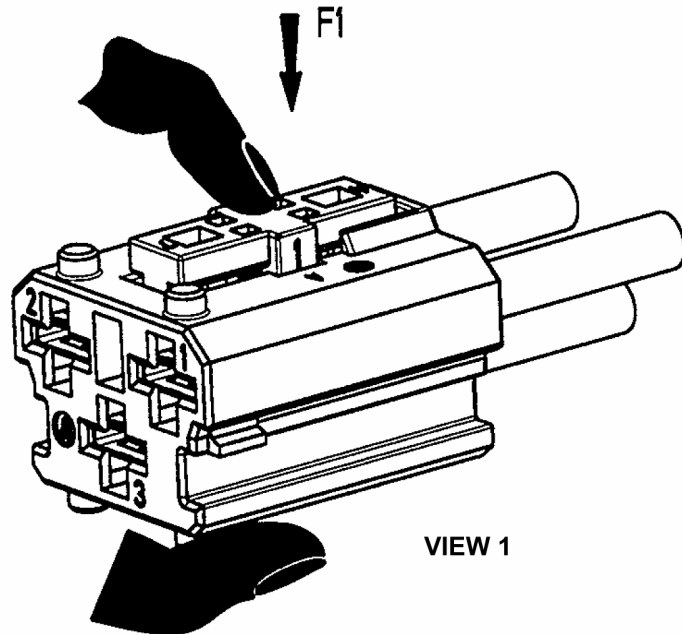

- IF THE CLIP IS NOT PROPERLY LOCKED, THE SECONDARY LATCH CANNOT BE CLOSED. SEE INTERFERENCE (VIEW 2 AND VIEW 3)

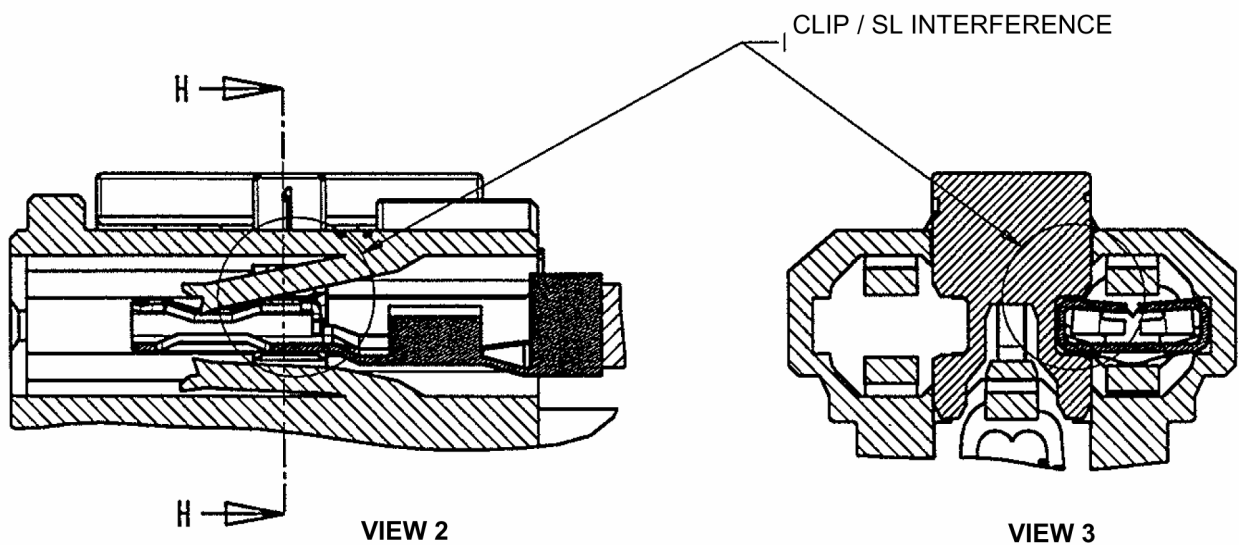

UTILISATION OF 6.35 mm 3-WAY CONNECTOR CH/TH

TAB HOLDER - WIRING (1)

- PRESENT THE TAB IN FRONT OF A SLOT,  
ON THE REAR OF THE TAB HOLDER, WITH  
DETECTION GRID AND CAM LOCKING IN  
PRE-ASSEMBLED POSITION (VIEW 1)

- NOTE THAT THE TAB IS REVERSIBLE  
THROUGH 180°

6.35 mm TAB NG1

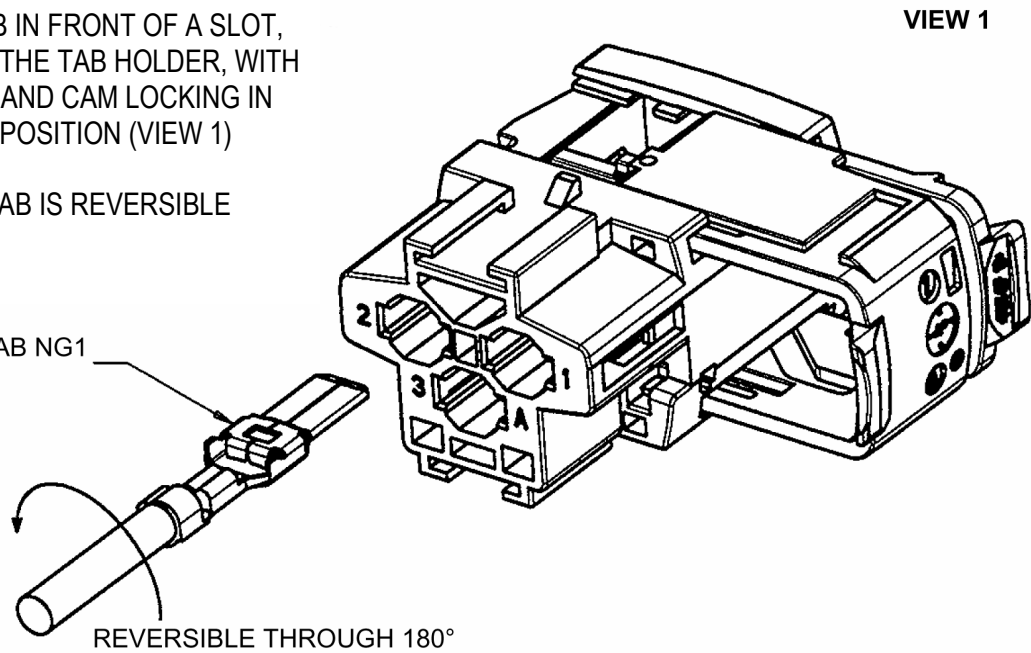

- THEN INSERT TAB ALONG F FULLY INTO THE SLOT (VIEW 2)

VIEW 2

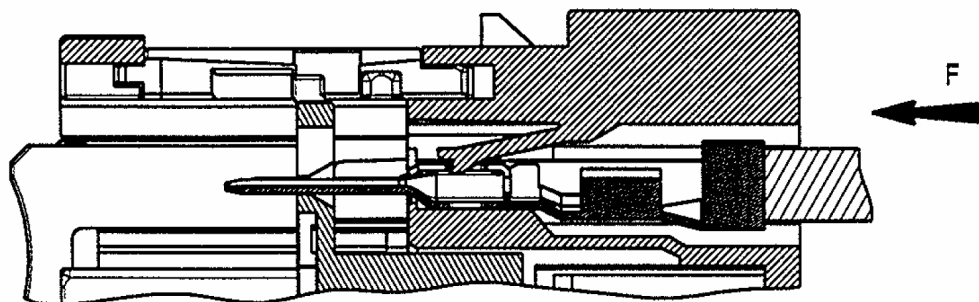

- IF THE DETECTION GRID IS CLOSED, THE TAB CANNOT BE INSTALLED OR LOCKED

UTILISATION OF 6.35 mm 3-WAY CONNECTOR CH/TH

CHECK CONTACT PRESENCE IN TAB HOLDER

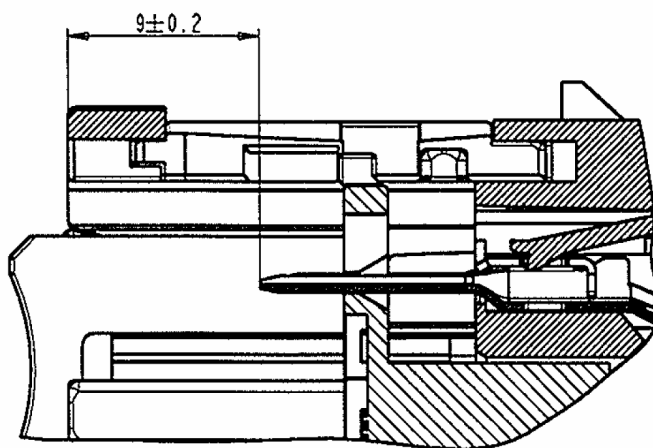
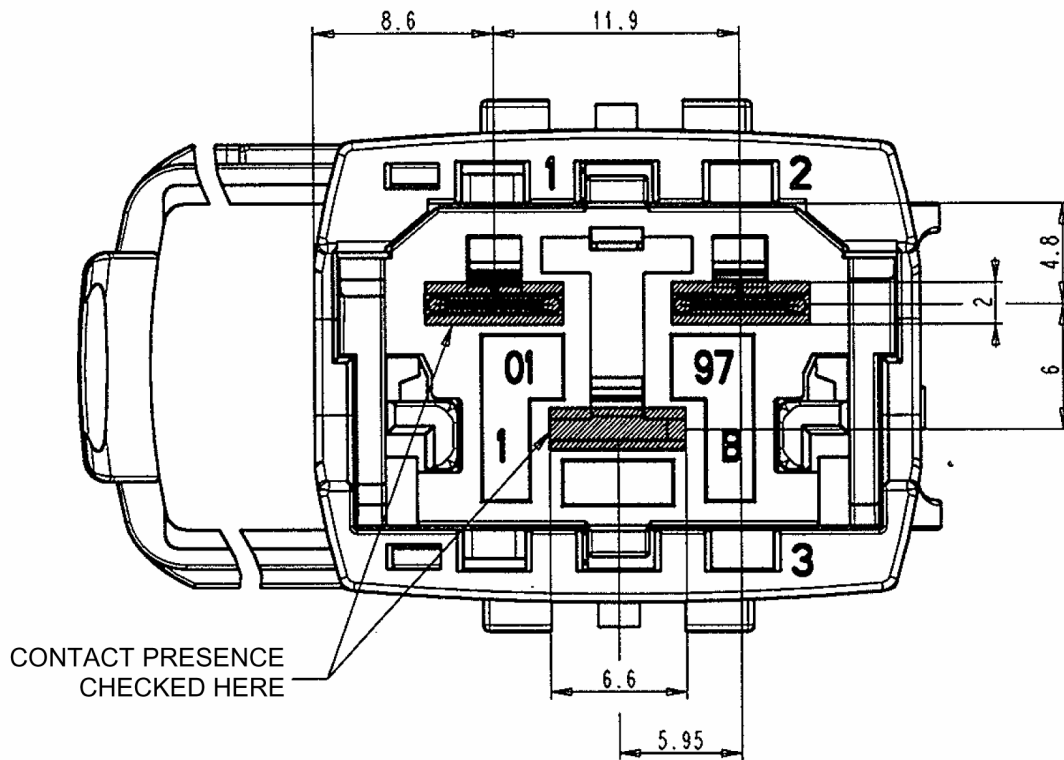

- CONTACT "PRESENCE IS CHECKED AFTER INSERTION AND LOCKING OF ALL TABS IN THE TAB HOLDER, AND BEFORE CLOSING THE DETECTION GRID

UTILISATION OF 6.35 mm 3-WAY CONNECTOR CH/TH

TAB HOLDER - WIRING (2)

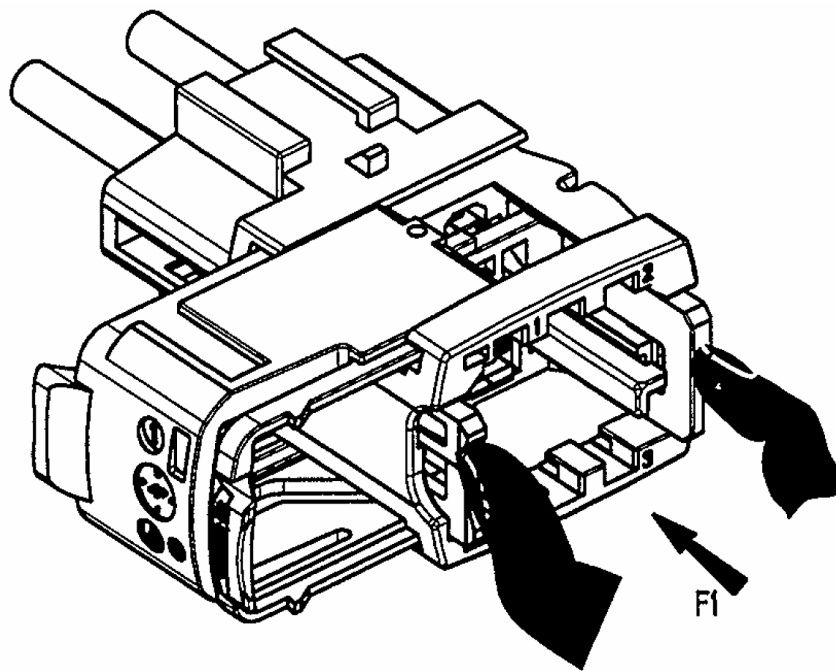

- WHEN ALL TABS HAVE BEEN INSERTED INTO THE TAB HOLDER, CLOSE THE DETECTION GRID BY PUSHING ALONG F1, AS SHOWN IN THE ABOVE DIAGRAM.

- IF THE TAB IS NOT PROPERLY LOCKED, THE DETECTION GRID CANNOT BE CLOSED



UTILISATION OF 6.35 mm 3-WAY CONNECTOR CH/TH

CLIP HOLDER - TAB HOLDER

- PRESENT THE CLIP HOLDER IN FRONT OF THE TAB HOLDER AND INSERT IT INTO THE SKIRT, ALONG F, INSERT FULLY, UNTIL THE CLIP HOLDER / CAM LOCKS ARE ENGAGED IN THE PREASSEMBLED POSITION

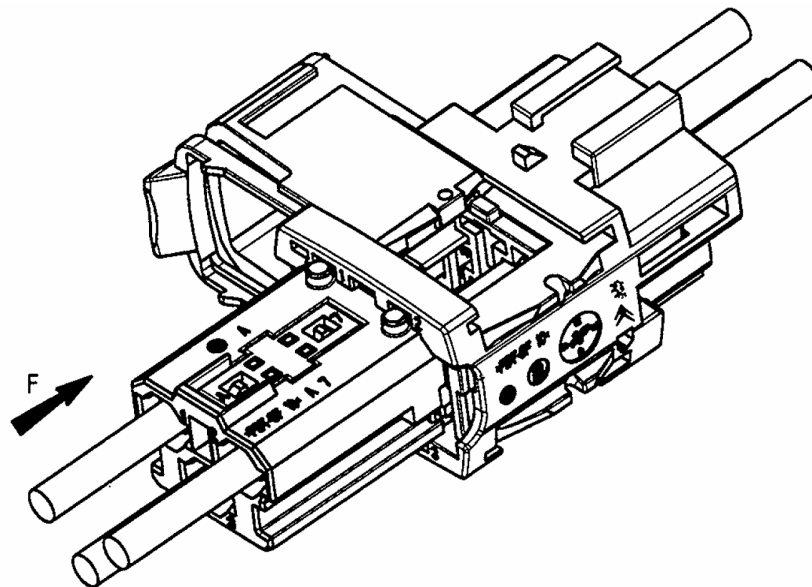

- IF THE CLIP HOLDER SECONDARY LATCH AND / OR THE TAB HOLDER DETECTION GRID REMAIN IN THE PREASSEMBLED POSITION, THE CLIP AND TAB HOLDERS CANNOT BE COUPLED.

CLIP HOLDER SECONDARY LATCH IN PREASSEMBLED POSITION PREVENTS INSERTION INTO TAB HOLDER SKIRT

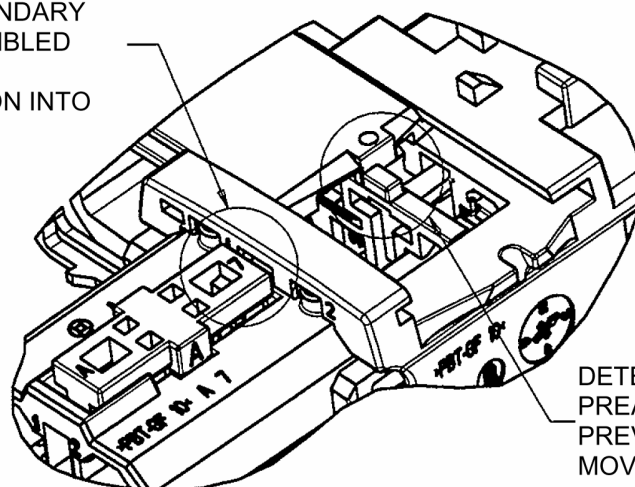

DETECTION GRID IN PREASSEMBLED POSITION PREVENTS CAM LOCKING MOVEMENT

UTILISATION OF 6.35 mm 3-WAY CONNECTOR CH/TH

CLIP HOLDER - TAB HOLDER COUPLING

- THE CONNECTOR IS PLUGGED TOGETHER BY MOVING THE CAM LOCKING

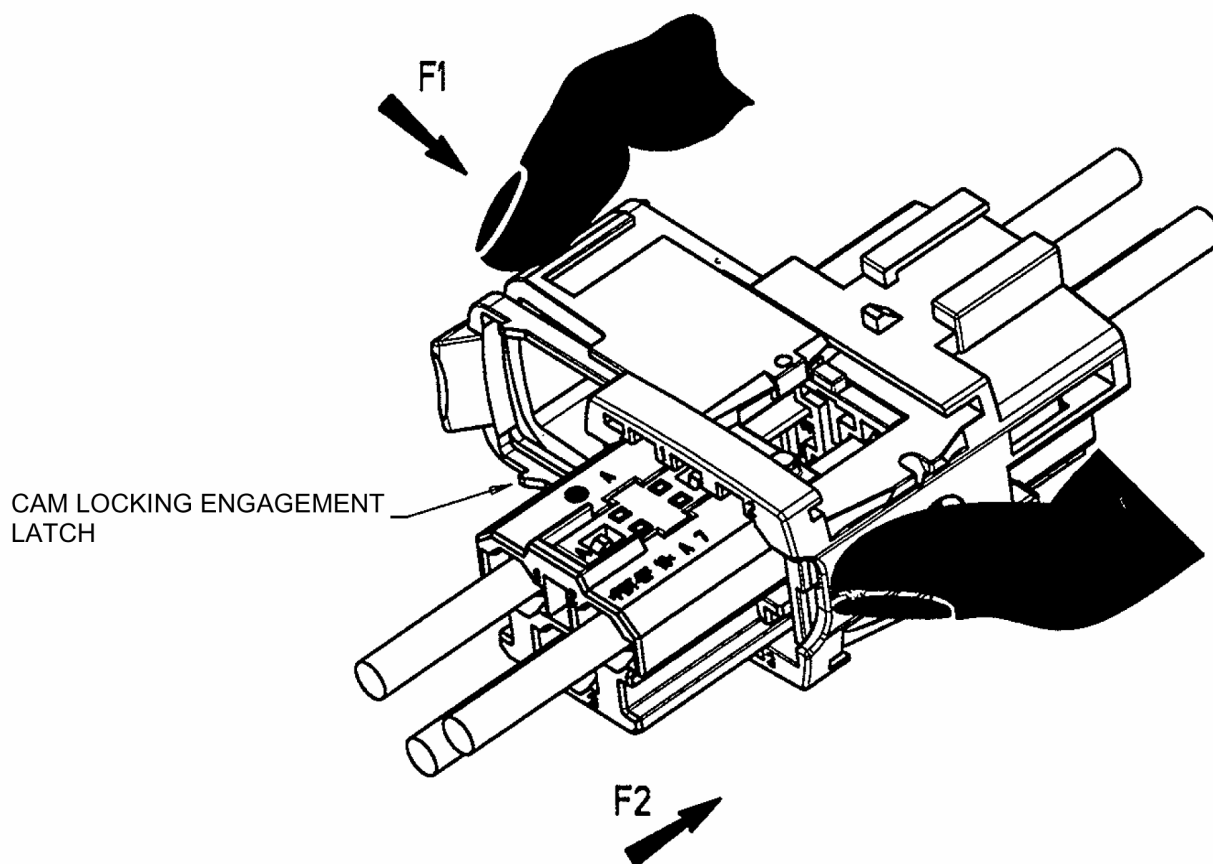

- PUSH ON THE CAM LOCKING, ALONG F1. THIS PUSHES THE CLIP HOLDER INTO THE TAB HOLDER SKIRT (ALONG F2) AND THE CONNECTOR COUPLING / LOCKING SYSTEM LOCKS THE C.L. IN POSITION.

**DISCONNECTING THE 6.35 mm 3-WAY CONNECTOR CH/TH**

**CLIP HOLDER - TAB HOLDER**

- TO DISCONNECT THE CONNECTOR, PROCEED AS FOLLOWS:

**VIEW 1**

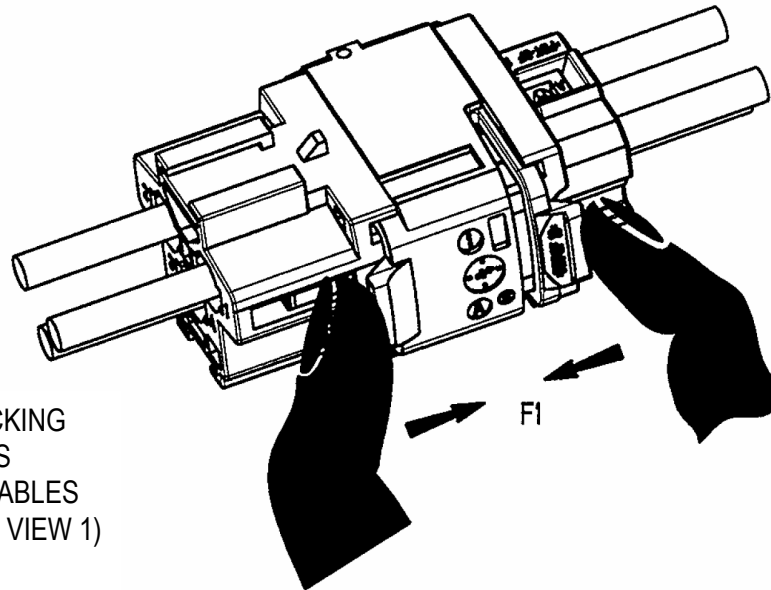

- FIRSTLY, UNLOCK THE CAM LOCKING BY PUSHING THE TWO CATCHES TOGETHER, ALONG F1. THIS ENABLES TRANSLATION MOVEMENT (SEE VIEW 1)

**VIEW 2**

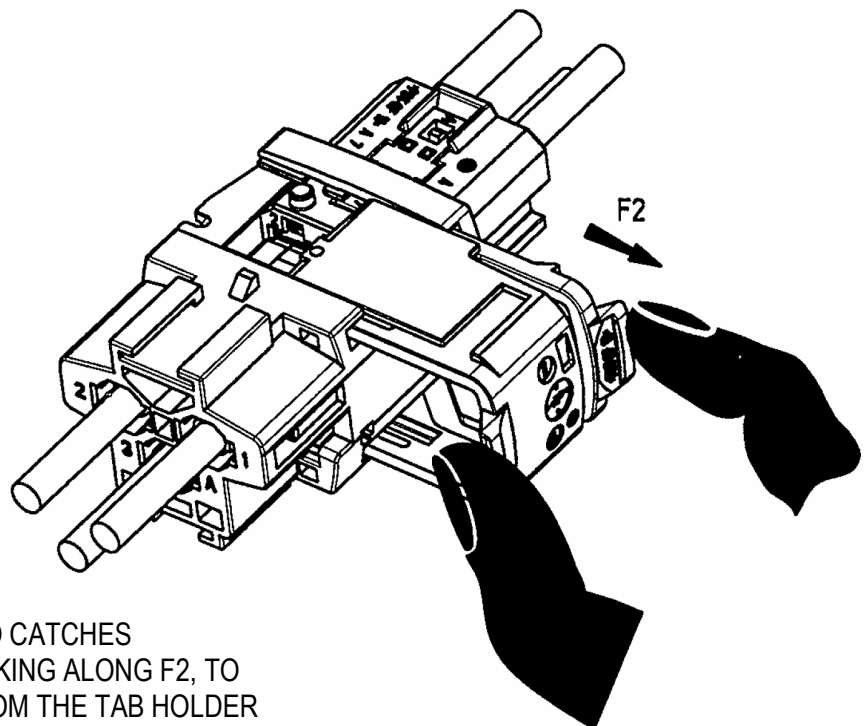

- THEN, WHILE HOLDING THE TWO CATCHES TOGETHER, PULL THE CAM LOCKING ALONG F2, TO EXTRACT THE CLIP HOLDER FROM THE TAB HOLDER  
- (SEE VIEW 2)

**REMOVAL AND REPAIR OF 6.35 mm 3-WAY CONNECTOR****CLIP HOLDER - WIRING (1)**

- USING A 2.5 mm SCREWDRIVER, RELEASE THE SECONDARY LATCH, TO RESTORE THE PREASSEMBLED POSITION, AS DESCRIBED BELOW.

- INSERT THE SCREWDRIVER INTO THE CENTRAL SLOT, AS SHOWN IN VIEW 1 (ON FRONT OR REAR OF CLIP HOLDER)

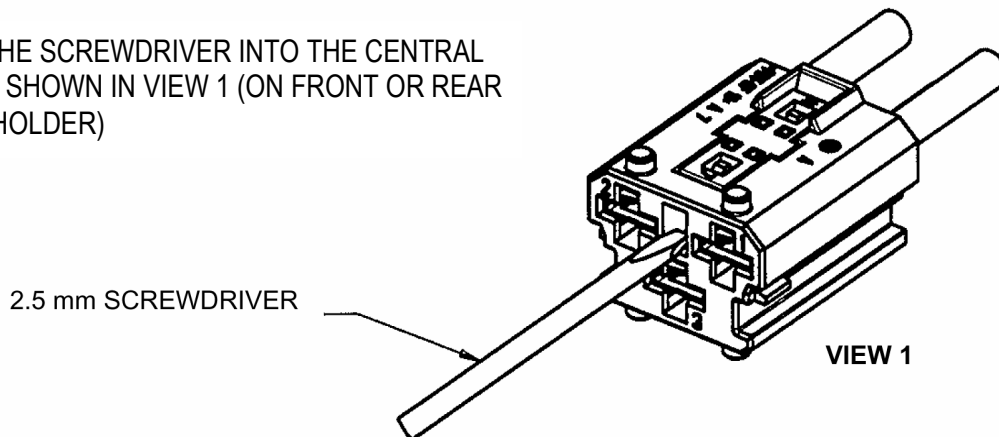

- THE SCREWDRIVER BLADE MUST BE INSERTED UNDER THE SECONDARY LATCH (VIEW 2)

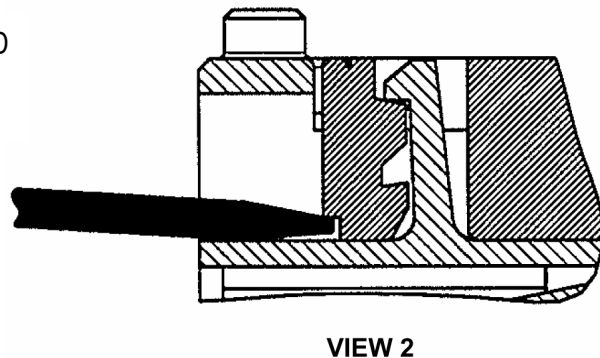

- THEN PUSH THE SCREWDRIVER HANDLE DOWN, ALONG F, TO LEVER THE SECONDARY LATCH INTO THE PREASSEMBLED POSITION.

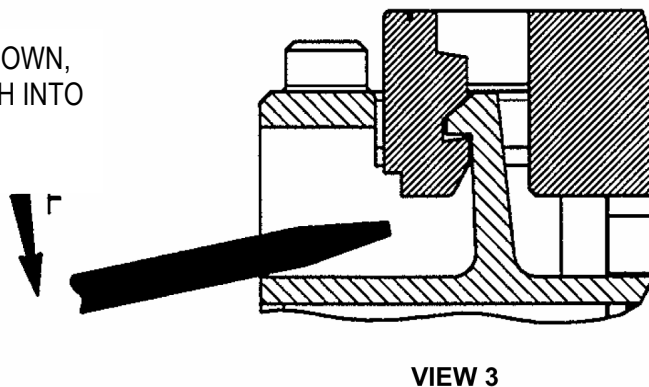

**REMOVAL AND REPAIR OF 6.35 mm 3-WAY CONNECTOR**

**CLIP HOLDER - WIRING (2)**

- THE CLIPS ARE ALSO REMOVED USING A 2.5 mm SCREWDRIVER.

- INSERT THE SCREWDRIVER INTO A SLOT, THROUGH THE FRONT OF THE CLIP HOLDER, AS SHOWN IN VIEW 1

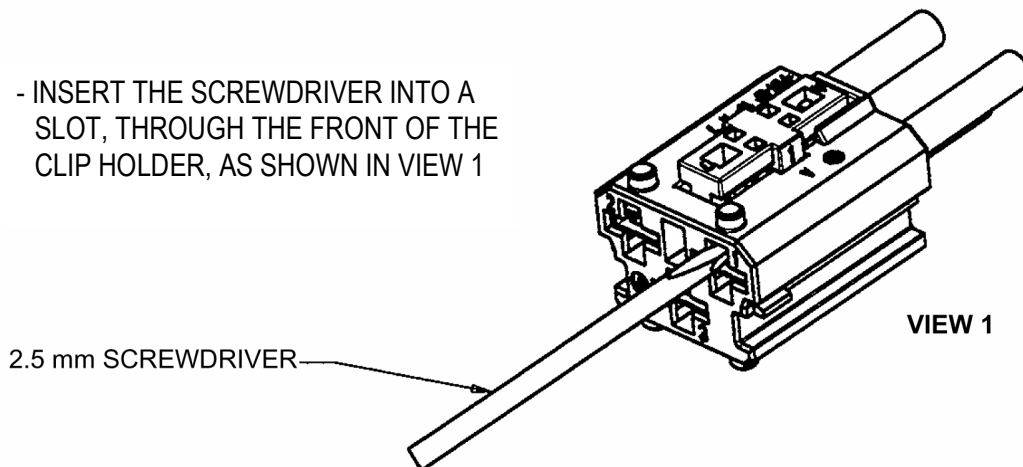

- THE SCREWDRIVER BLADE MUST BE INSERTED BETWEEN THE CLIP CAGE AND THE PRIMARY LATCH. THEN PUSH THE SCREWDRIVER HANDLE UP, ALONG F1, TO RELEASE THE PRIMARY LATCH (VIEW 2)

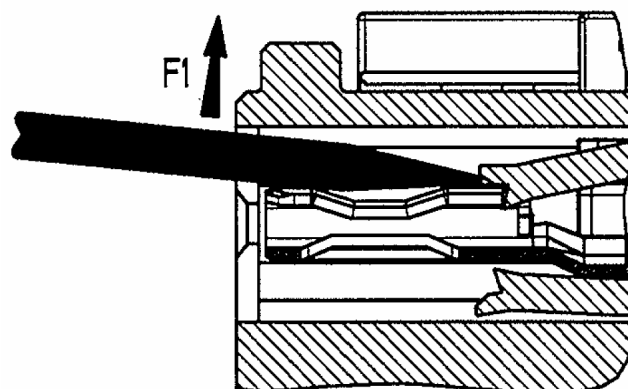

- THEN PULL ON THE CABLE TO THE CLIP FROM ITS SLOT.

VIEW 2

**REMOVAL AND REPAIR OF 6.35 mm 3-WAY CONNECTOR**

**TAB HOLDER - WIRING (1)**

- REMOVE THE DETECTION GRID, TO RESTORE THE PREASSEMBLED POSITION, USING A 2.5 mm SCREWDRIVER, AS DESCRIBED BELOW.

- INSERT THE SCREWDRIVER AS SHOWN IN VIEW 1

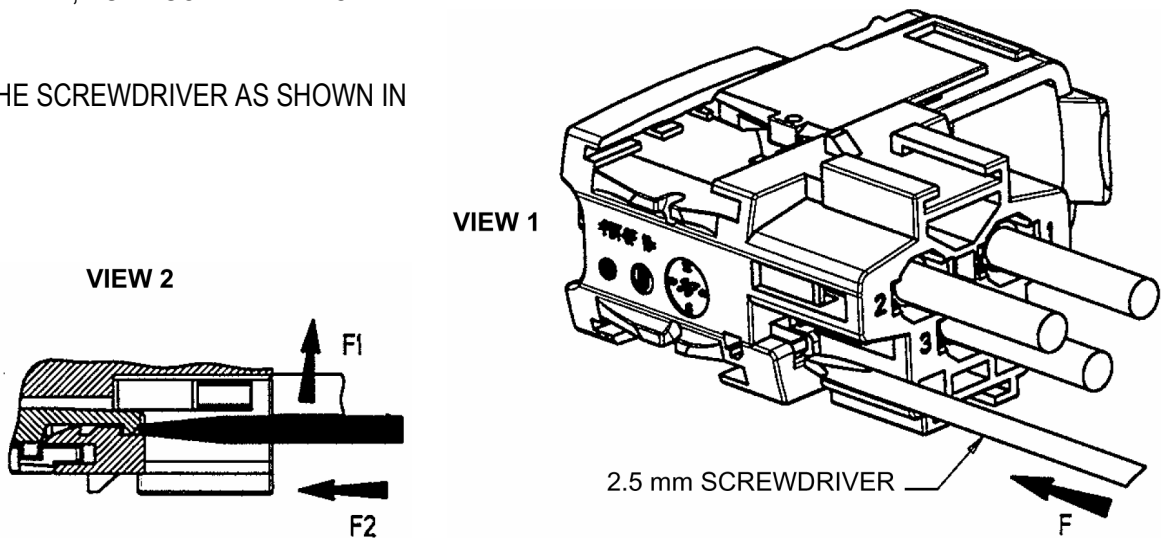

- INSERT THE SCREWDRIVER BLADE ALONG F, TO INSERT IT UNDER THE DETECTION GRID LOCKING CATCH (VIEW 2)  
THEN PUSH THE SCREWDRIVER HANDLE UP, ALONG F1, TO RELEASE THE CATCH, AND REPEAT THIS OPERATION (ALONG F2) FOR THE SECOND CATCH. THIS RESTORES THE PREASSEMBLED POSITION

- IF THE DETECTION GRID DOES NOT FULLY RETURN TO ITS PREASSEMBLED POSITION, APPLY CORRECTIVE ACTION, ALONG F3, MANUALLY (VIEW 3).

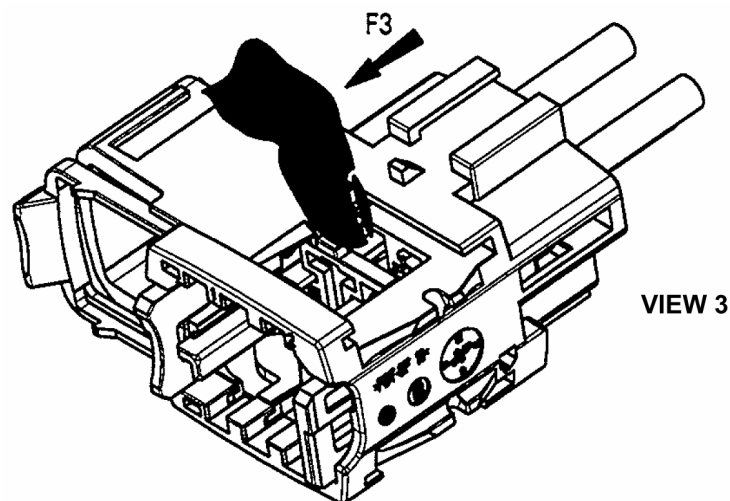

REMOVAL AND REPAIR OF 6.35 mm 3-WAY CONNECTOR

TAB HOLDER - WIRING (2)

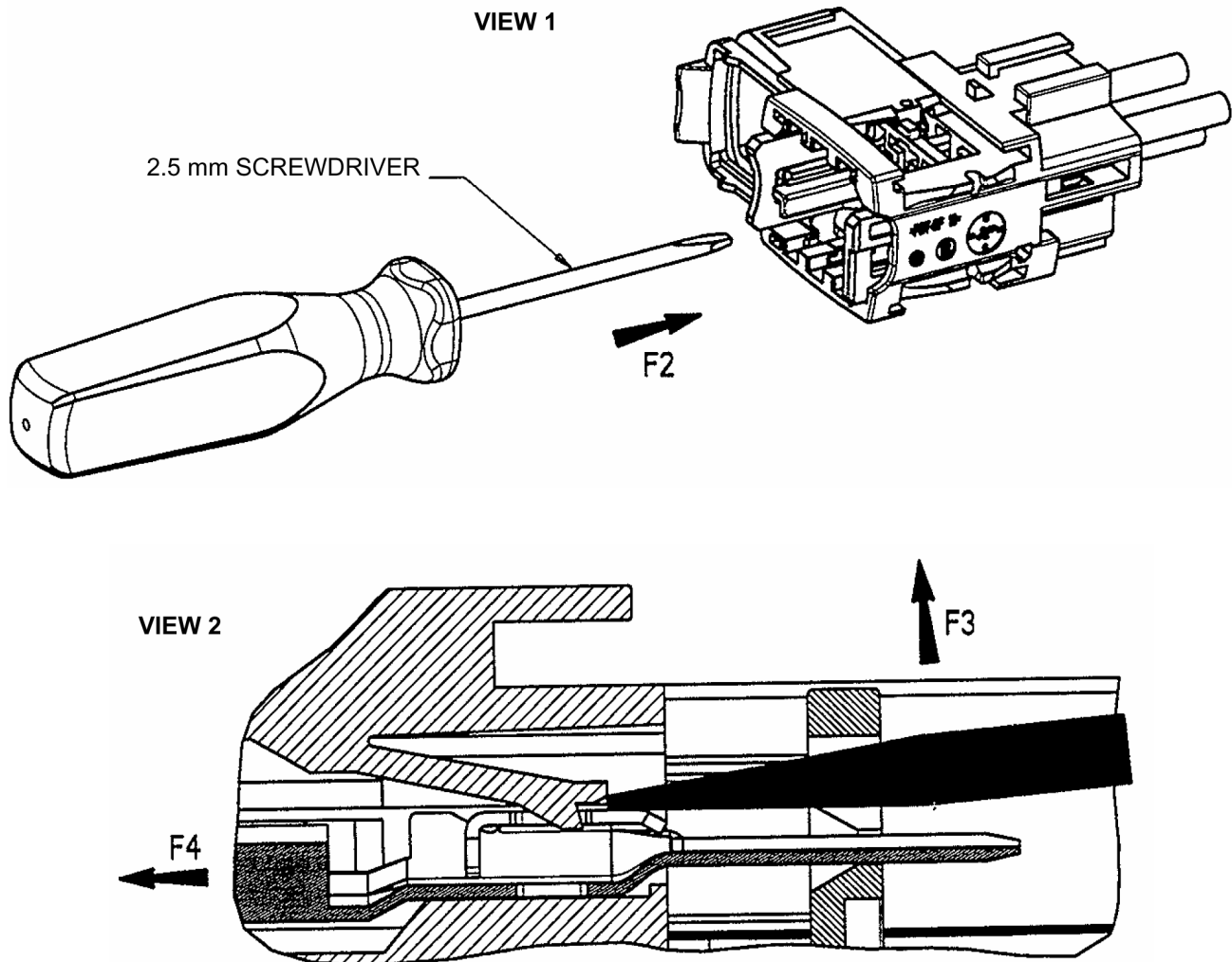

- WHEN THE DETECTION GRID HAS BEEN RETURNED TO ITS PREASSEMBLED POSITION, THE TABS MAY BE REMOVED AS DESCRIBED BELOW.

- INSERT THE SCREWDRIVER, ALONG F2, INTO ONE OF THE DETECTION GRID SLOTS (VIEW 1)

- THEN INSERT THE SCREWDRIVER BLADE UNDER THE PRIMARY LATCH AND RAISE THE SCREWDRIVER HANDLE, ALONG F3 (VIEW 2) TO RELEASE THE TAB, SO THAT IT CAN BE EXTRACTED, ALONG F4.

6.35 mm 3-WAY CONNECTOR - WIRING APPENDIX

CLIP HOLDER AND TAB HOLDER

POSITION OF END OF OUTER SHEATH

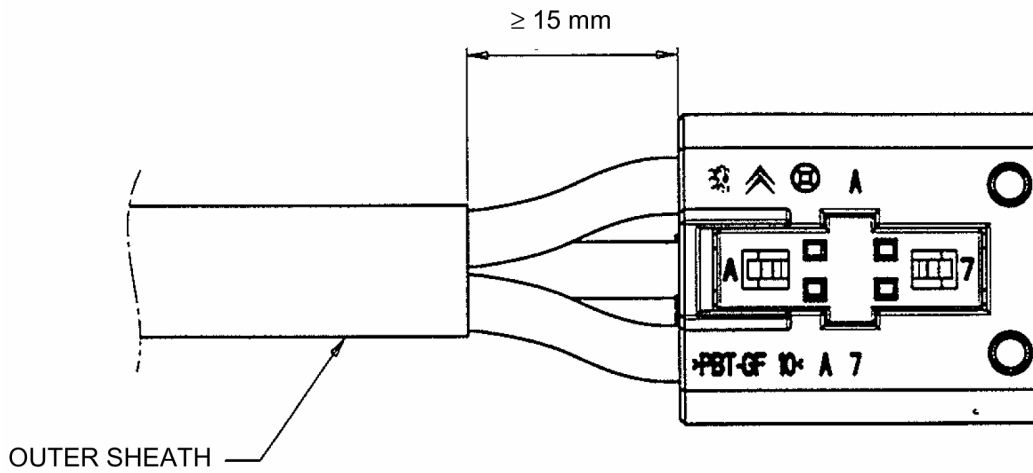

MINIMUM RADIUS

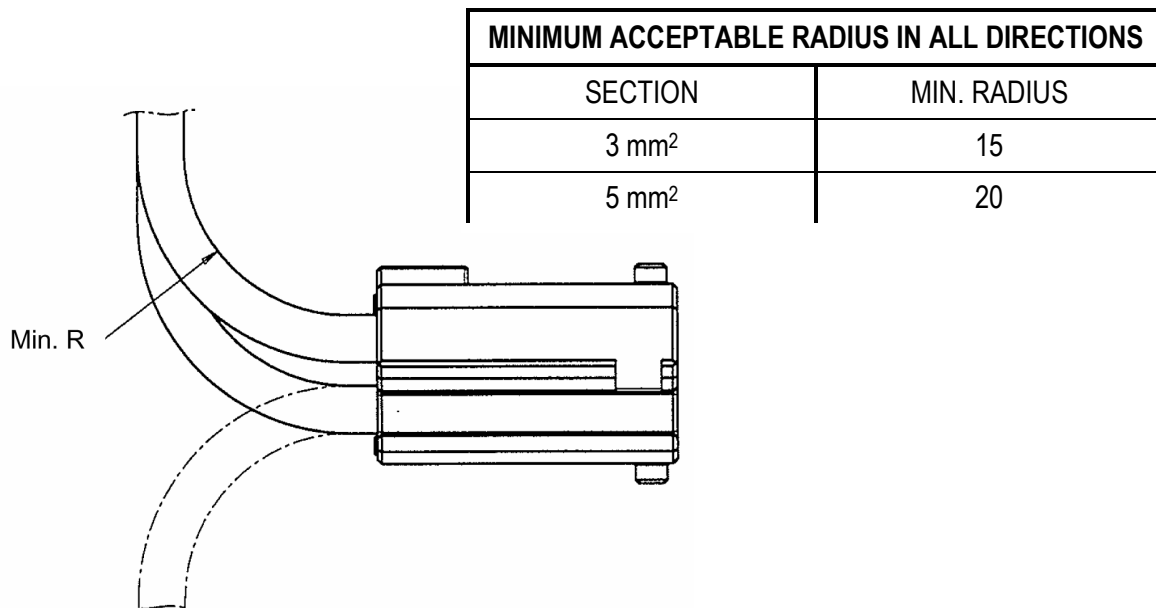



**6.35 mm 3-WAY CONNECTOR - TRACEABILITY**

**CLIP HOLDER - TAB HOLDER**

MOLDING COMPONENTS STAMPS  
(LETTER for MONTH / NUMBER for YEAR)

