

MALE PIN CONTACT	
PART NUMBER	DESCRIPTION
1488220-[]	Tin Plated
1488208-[]	Gold Plated

OPTIONAL HOLD-DOWN ATTACHMENT	
PART NUMBER	DESCRIPTION
345484-1 ■	Body Clip
184288-1 ■	Anti-Rotational Body Clip
1437839-1	Insulator Mounting Clip

■ This hold-down attachment is NOT compatible with all cap connectors. Call PRODUCT INFORMATION at the number at the bottom of this page for compatibility.

Figure 1

1. INTRODUCTION

Sealed Cap Connector Assemblies 1488750-[] accept the male pin contacts listed in Figure 1. A hold-down attachment can be used to mount the cap connector to the automotive panel. Available attachments are listed in Figure 1. These cap connectors mate with 1 × 3 sealed plug connector assemblies. Refer to instruction sheet 408-8630 for assembly of the mating connector.

NOTE



Dimensions in this instruction sheet are in millimeters [with inches in brackets]. Figures are not drawn to scale.

These instructions cover assembly (inserting the contacts into the cap connector, installing a hold-down attachment, and mating the connectors) and disassembly (unmating the connectors and extracting the contacts from the cap connector) procedures. Recommended probe locations for continuity testing is also covered.

A flat-blade screwdriver with a tip having a width between 0.8 and 1.0 mm is required for contact extraction.

Reasons for reissue of this instruction sheet are provided in Section 6, REVISION SUMMARY.

2. DESCRIPTION

Each cap connector features a housing with contact cavities, mating latch bumps, a seal cover, keying slot, TPA lock, and a hold-down retainer. Refer to Figure 1.

The contact cavities are polarized to prevent the contacts from being inserted upside-down. When inserted into the housing, the contact deflects the housing retention finger, locking the contact into place. After all contacts are inserted, the TPA lock is used to ensure that the contacts are fully seated and to provide additional contact retention.

The cap connector is shipped with the TPA lock in the pre-lock (OPEN) position. The lock is actuated when moved to the final-lock (CLOSED) position.

The hold-down retainer is used to attach the hold-down attachment to the cap connector.

When mating connectors, the mating latches of the cap connector engage the locking tabs of the plug connector to prevent separation.

3. ASSEMBLY

3.1. Inserting Contacts

The following procedure assumes that the contacts have been properly crimped. For detailed inspection requirements, refer to Application Specification 114-13006.

Proceed as follows:

1. Ensure that the TPA lock of the cap connector is in the OPEN position as shown in Figure 2, Detail A. If it is not, follow Step 2 in Paragraph 4.2.
2. Grasp the wire of the contact approximately 20 [.75] behind the insulation barrel (refer to Figure 1).
3. Align the contact with the desired contact cavity at the wire end of the cap connector, orienting the contact so that the retention window is facing the bottom of the cap connector. See Figure 2, Detail B. Push the contact straight into the contact cavity until it stops (there will be an audible “click”).

CAUTION  To avoid damage to the seal (located behind the seal cover), ALWAYS push the contact STRAIGHT into the contact cavity.

CAUTION  DO NOT force the contact into the contact cavity. If there is resistance or the wire “buckles,” pull the contact out, ensure proper orientation, and re-insert the contact.

4. After all contacts are inserted, push the TPA lock into the housing until the TPA lock is in the CLOSED position. Make sure to avoid pushing the tips of the contacts. The TPA lock is in the CLOSED position when it is flush with the contact cavities. See Figure 3. The recommended method of closing the TPA lock is to mate the cap connector with an empty plug connector.

NOTE  If the TPA lock does not fully close, pull the TPA lock to the OPEN position, ensure that all contacts are fully seated, then try again. DO NOT force the TPA lock to close.

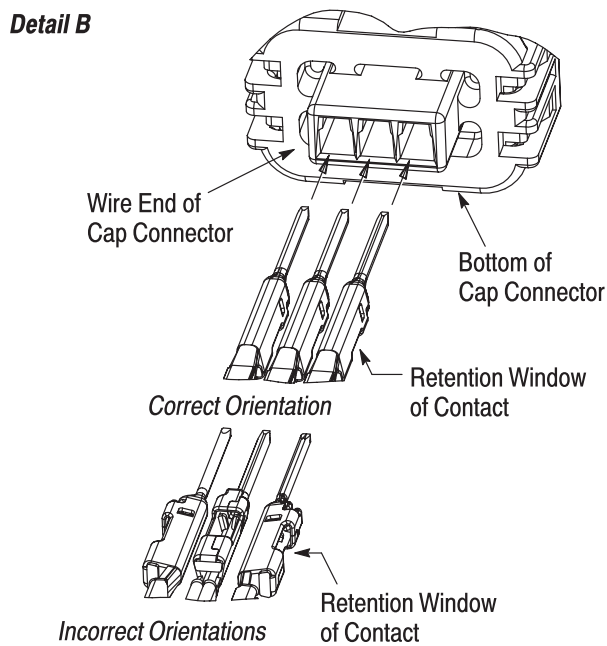
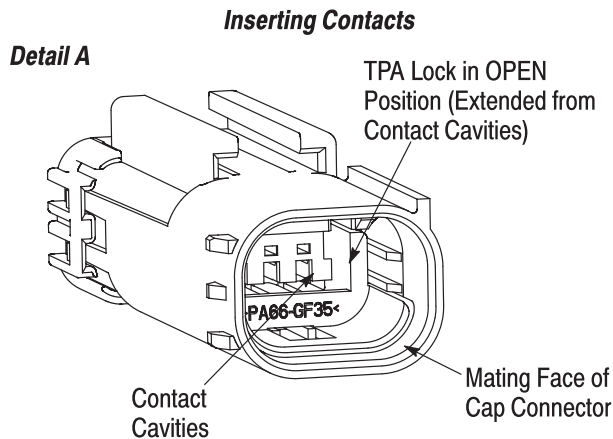

Figure 2

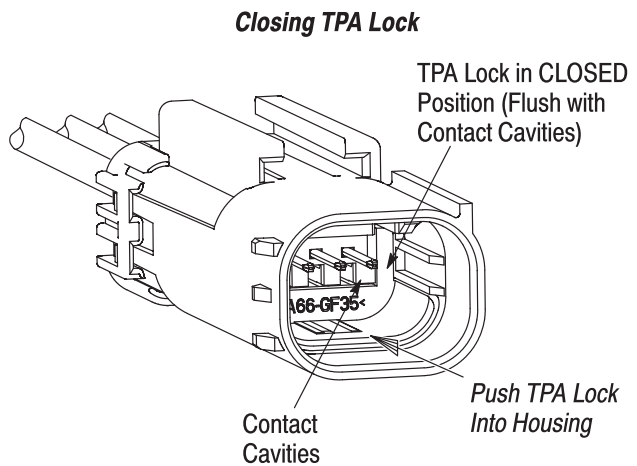

Figure 3

3.2. Installing Hold-Down Attachment

1. Align the hold-down attachment with the mating face of the cap connector so that the end of the base faces the end of the hold-down retainer of the cap connector. See Figure 4.

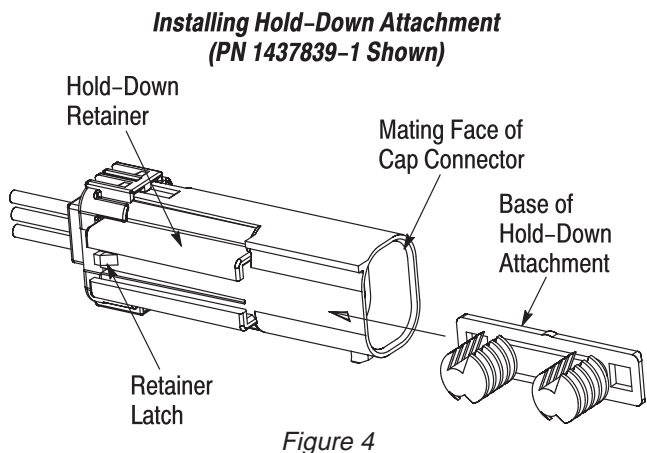

Figure 4

2. Slide the hold-down attachment onto the cap connector until it engages the retainer latch of the cap connector. See Figure 5.

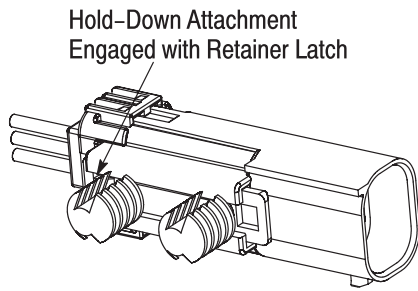

Figure 5

3.3. Mating Connectors

1. Align the mating faces of the connectors so that the three mating latch bumps of the cap connector are on the same side as the connector position assurance (CPA) lock of the plug connector. See Figure 6, Detail A.
2. Push the connectors together, making sure that the key of the cap connector enters the keying slot of the plug connector, until the mating latch bumps and mating latch engage (there will be an audible “click”).
3. Slide the CPA lock of the plug connector toward the cap connector until it is in the CLOSED position. The CPA lock is in the CLOSED position when the slide rails are completely exposed. See Figure 6, Detail B.

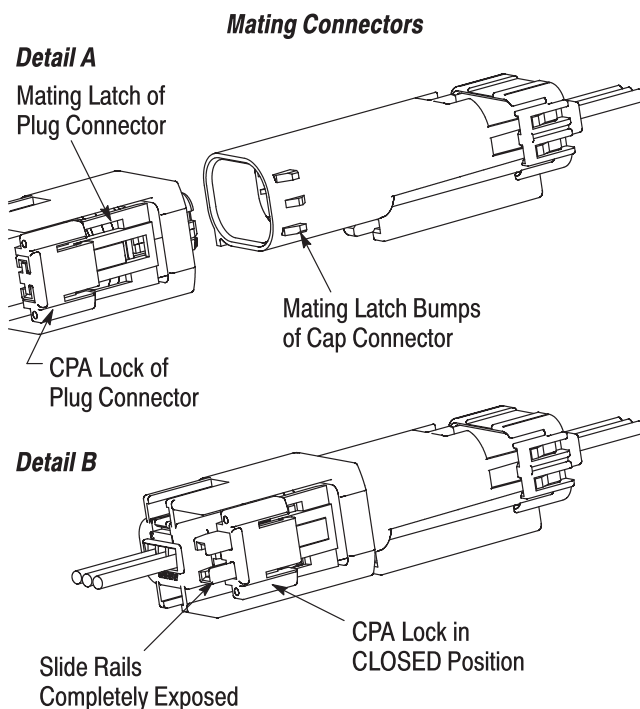

Figure 6



CAUTION DO NOT force the CPA lock to close. The CPA lock will not close unless the connectors are fully mated. If the CPA lock is difficult to close, try to push the connectors together further.

4. DISASSEMBLY

4.1. Unmating Connectors

1. Move the CPA lock of the plug connector into the OPEN position (refer to 408-8630 for instruction). The CPA lock MUST be in the OPEN position before unmating the connectors.
2. Depress the locking latch of the plug connector, and pull the cap connector straight away from the plug connector.

4.2. Removing Contacts

1. Unmate the connectors (as described in Paragraph 4.1).
2. Move the TPA lock to the OPEN position by inserting the tip of the screwdriver into the notch at the base of the TPA lock and pivoting the screwdriver away from the contacts. The TPA lock is in the OPEN position when it extends from the contact cavities. See Figure 7.

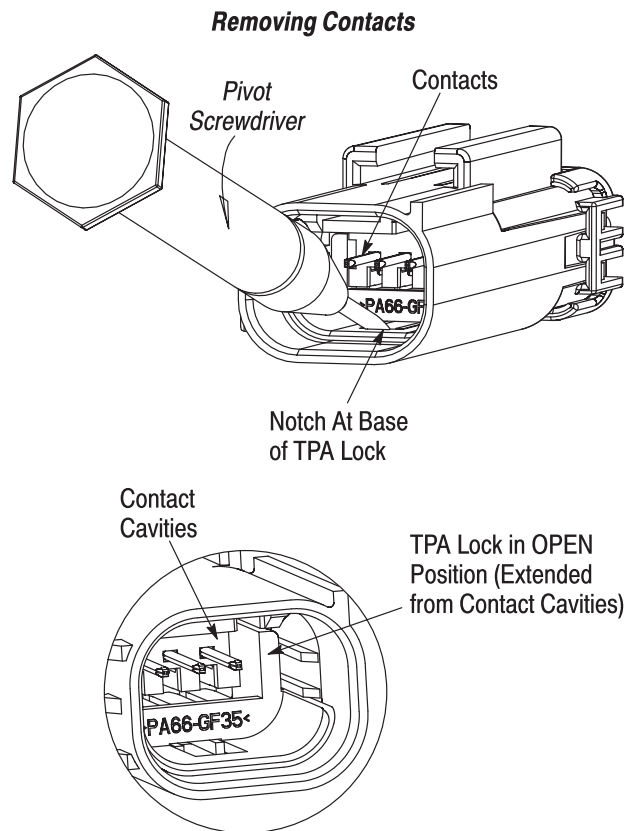

Figure 7

Removing Contacts

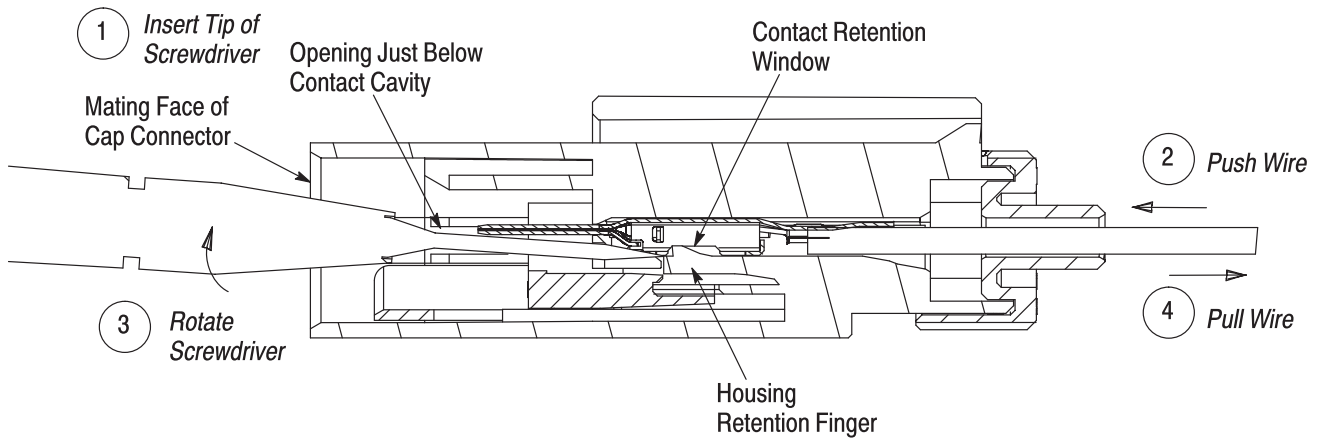

Figure 8

3. At the mating face of the cap connector, insert the tip of the screwdriver into the opening just below the contact cavity of the contact to be removed until it stops. Refer to Figure 8.

4. Holding the screwdriver in place, *gently* push the wire of the contact to be removed toward the housing until it stops (this will relieve the pressure on the contact retention window).

5. Rotate the screwdriver toward the contact to lift the housing retention finger away from the contact retention window. Refer to Figure 8. While holding the screwdriver in position, pull the wire until the contact is released, then pull the contact straight out of the contact cavity.



To avoid damage to the seal (located behind the seal cover), **ALWAYS** pull the contact **STRAIGHT** out of the contact cavity.

6. Pull the screwdriver out of the cap connector.

7. Push the TPA lock into the housing until it is in the CLOSED position as described in Step 4 of Paragraph 3.1.

4.3. Continuity Testing

It is recommended to touch the probe to each contact box. Refer to Figure 9.



TAKE CARE not to damage the tips of the contacts.

5. REPLACEMENT AND REPAIR

The contacts and housings are not repairable. **DO NOT** use any defective or damaged contacts or connectors. **DO NOT** re-use a terminated contact by removing the wire.

Probe Location

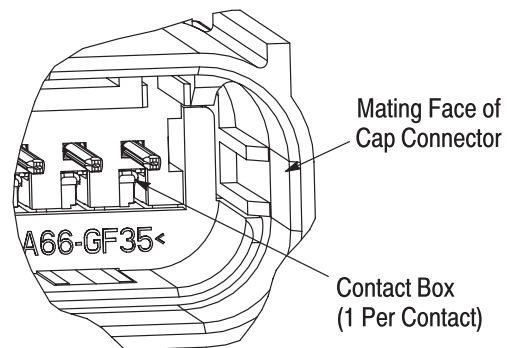

Figure 9

6. REVISION SUMMARY

Revisions to this instruction sheet include:

- Updated document to corporate requirements