



1. INTRODUCTION

This instruction sheet covers the installation and operation of the Type PROTMR Universal Timing Relays. Read these instructions thoroughly before installing the relay.

NOTE

Dimensions in this instruction sheet are in millimeters [with inches in brackets]. Figures are not drawn to scale.

2. DESCRIPTION

The universal timer can be used as an On-Delay relay, an Off-Delay relay, an electronically-held interval relay, or a latching interval relay.

The output contacts of the PROTMR timer are contained in a replaceable plug-in relay. Select the MP relay according to the control voltage used to operate the timer. The MP relay must be ordered separately.

Each relay is an accurate instrument using a minimum of moving parts. When satisfactory performance cannot be restored, the unit should be returned to Cutler-Hammer for repair or replacement.

3. MOUNTING DIMENSIONS

Refer to Figure 1 for mounting dimensions.

4. WIRING (Figure 2)

NOTE

The terminal markings shown for the timer are different from the plug-in relay terminal markings. Install jumper connection between terminals 7 and 8 for 24 or 48 volt operation (AC or DC).

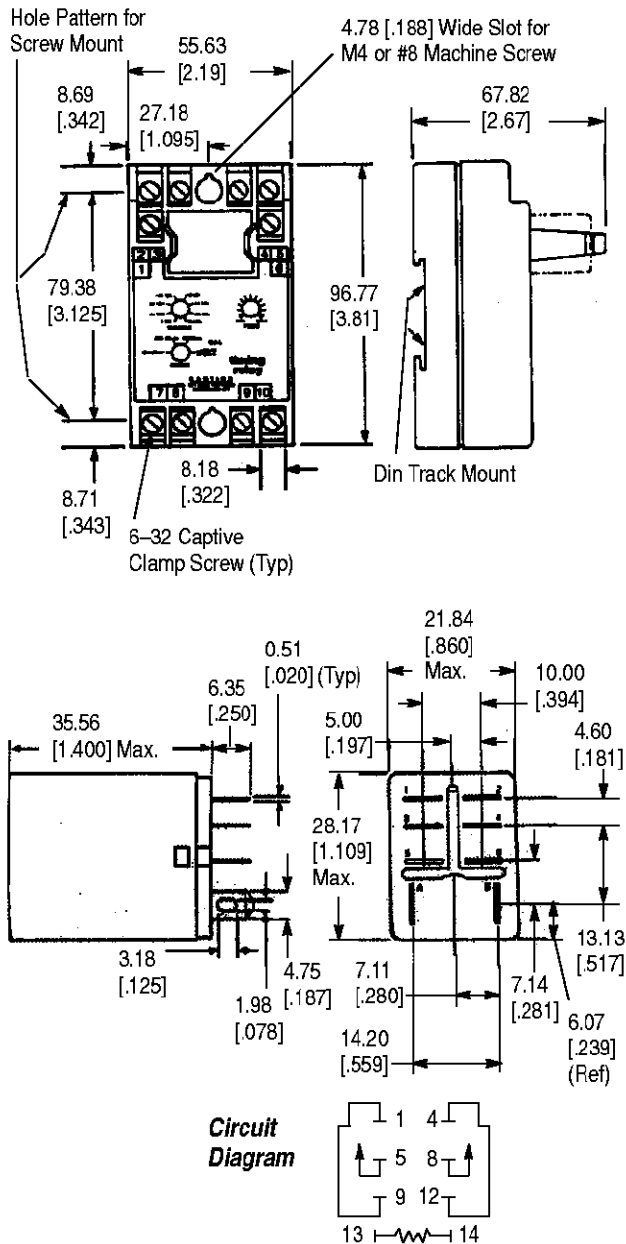
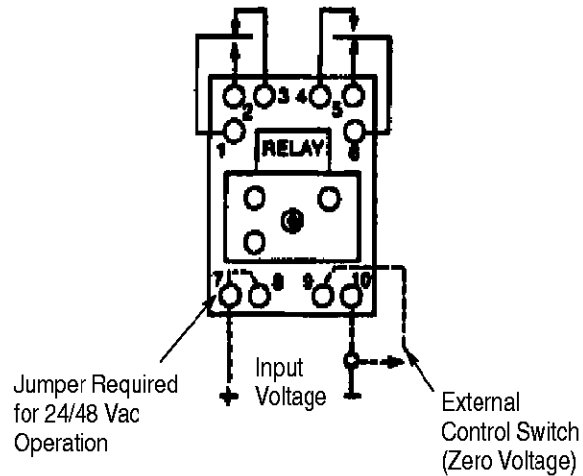

Figure 1



NOTE: External Wiring Shown by Broken Lines.

OUTPUT RELAY OPERATING VOLTAGES

120 Vac	48 Vdc
240 Vac	24 Vdc
24 Vac	110 Vdc
48 Vac	

Figure 2

5. OPERATION

With power removed from timer, set desired mode and range with appropriate controls on face of timer.

NOTE *Timer mode and range will not change unless power is removed.*

Install relay and apply operating voltage to timer. Set timer delay with “time” adjust control on face of timers.

The minimum allowable duration of the control path closure for mode Types 2 and 4 (listed below) is 100 ms.

6. OPERATIONAL MODES

6.1. Type 1: On-Delay (Figure 3)

Time delay initiated upon application of operating voltage and closure of the control path. If both are maintained, output relay transfers upon expiration of time delay. If either is interrupted, timer will reset and, if the time delay has also expired, the output relay will release.

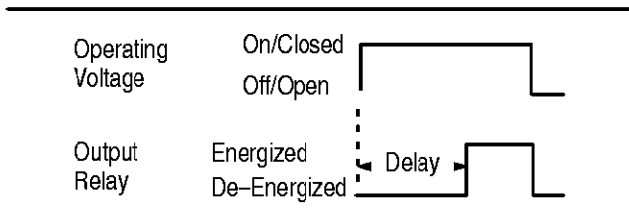

Figure 3

6.2. Type 2: Off-Delay (Figure 4)

Operating voltage applied continuously. Output relay transfers upon closure of control path. Time delay initiated upon opening of control path. If control path remains open, output relay releases upon expiration of time delay. If control path is re-closed prior to expiration of time delay, timer will reset.

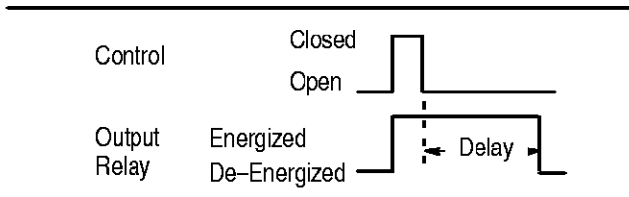

Figure 4

6.3. Type 3: Interval (Figure 5)

Output relay transfers and time delay is initiated upon application of operating voltage and closure of the control path. If both are maintained, output relay will release upon expiration of time delay. If either is interrupted prior to expiration of time delay, output relay will release and timer will reset. If either is interrupted after expiration of time delay, timer will reset.

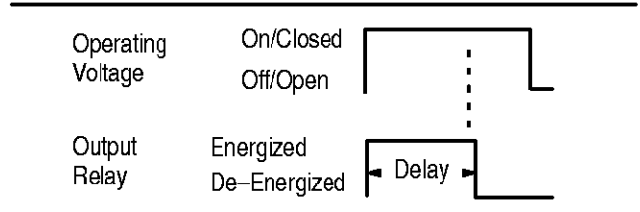

Figure 5

6.4. Type 4: Latching Interval (Figure 6)

Operating voltage applied continuously. Output relay transfers and time delay is initiated upon closure of control path. Opening and closing of control path prior to the expiration of the time delay will not reset the timer. Upon expiration of the time delay, output relay releases. If the control path is not open when the time delay expires, it must be opened before the next cycle can be initiated.

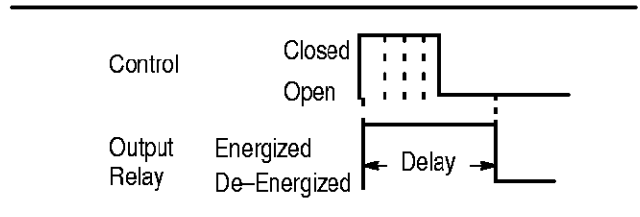

Figure 6

7. QUALIFICATIONS

The Type PROTMR Universal Timing Relays are recognized components by Underwriters Laboratories Inc. (UL) under File No. E15631, and certified to the Canadian Standards Association (CSA) under File No. LR29186.

8. REVISION SUMMARY

Per EC 0990-1531-01:

- Initial release of instruction sheet