

Figure 1

1. INTRODUCTION

These instructions cover Heavy Duty/Side Feed applicators that crimp Fully Insulated FASTON terminals on wire that has been pre-stripped.

These applicators are used on:

- A modified AMP-O-ELECTRIC* Model "K" Terminating Machine 565435-5. See Customer Manual 409-5128.

NOTE



The Model "K" AMP-O-ELECTRIC Terminating Machine 565435-5 has been superseded by the Model "G" Terminating Machine 354500-1 for new applications. For existing applications, the Model "K" is still recommended because of the large number of installed machines.

- An AMP-O-ELECTRIC Model "G" Terminating Machine 354500-[]. See Customer Manual 409-5842.
- A standard "T" Terminating Unit when installed on the Model IV-A AMPOMATOR* Machine. See Customer Manual 409-5289.

The terminals are retained in a plastic housing and are supplied in reel form to be fed into the applicator. The terminals are sheared from the carrier strip before they are crimped to the ends of the pre-stripped wire. Refer to the documentation package supplied with applicator for the terminal number, wire disc setting (A through D) for each wire size, and the required crimp height.

This instruction sheet, Document Package 854060-1, Applicator Installation Sheet 408-8098, the assembly drawing packaged with the applicator, the appropriate machine manual, and the machine conversion kit provide all the information required to operate and maintain the applicator and machine.

Pay particular attention to DANGER, CAUTION, and NOTE statements.

DANGER



Denotes an imminent hazard which may result in moderate or severe injury.



Denotes a condition which may result in product or equipment damage.



Highlights special or important information.



Compressed air used for cleaning this applicator must be reduced to less than 207 kPa [30 psij], and effective chip guarding and personal protective equipment (including eye protection) must be used.

Reasons for reissue of this instruction sheet are provided in Section 8, REVISION SUMMARY.

2. DESCRIPTION

Major components of the applicator are identified in Figures 1 through 7.

The terminal strip enters the applicator from the left, passing under the terminal drag between the strip guides. The lead terminal is always positioned in the "target area," and centered over the anvil, at the beginning of each cycle. This requires air pressure to be applied to the extension port of the feed air cylinder.

On the downward stroke of the ram, air pressure to the cylinder is stopped, allowing the internal spring pressure within the cylinder to retract the feed finger.

As the ram begins the upward stroke, air pressure to the air cylinder starts to move the feed finger. By the time the ram is completely lifted, the feed finger has moved forward, placing the terminal and carrier strip over the anvil and shear plate, and under the shear blade. The motion of the ram controls several cams, which actuate two valves which power the terminal feed, insertion, and terminal back-up. A simplified description of shearing, crimping, and insertion follows. As the ram begins its downward stroke, the insert cam actuates the latch mechanism, and the latch drops, holding the terminal insertion mechanism.

Approximately half way through the downward stroke, the terminal back-up moves up, and the insertion cylinder is activated. At bottom of ram travel, the terminal is crimped to the wire by the crimper.

When the termination is completed, the ram begins its upward stroke, allowing the crimper to release the terminated wire. During the upward stroke of the ram, the latch releases the insertion mechanism and the insulating housing is inserted over the crimped terminal to complete the cycle.

The applicator ram contains the insulation crimper, wire crimper, spacers, and cams. The cams (one on each side of the ram) actuate the valves and the insertion latch assembly. See Figure 3.

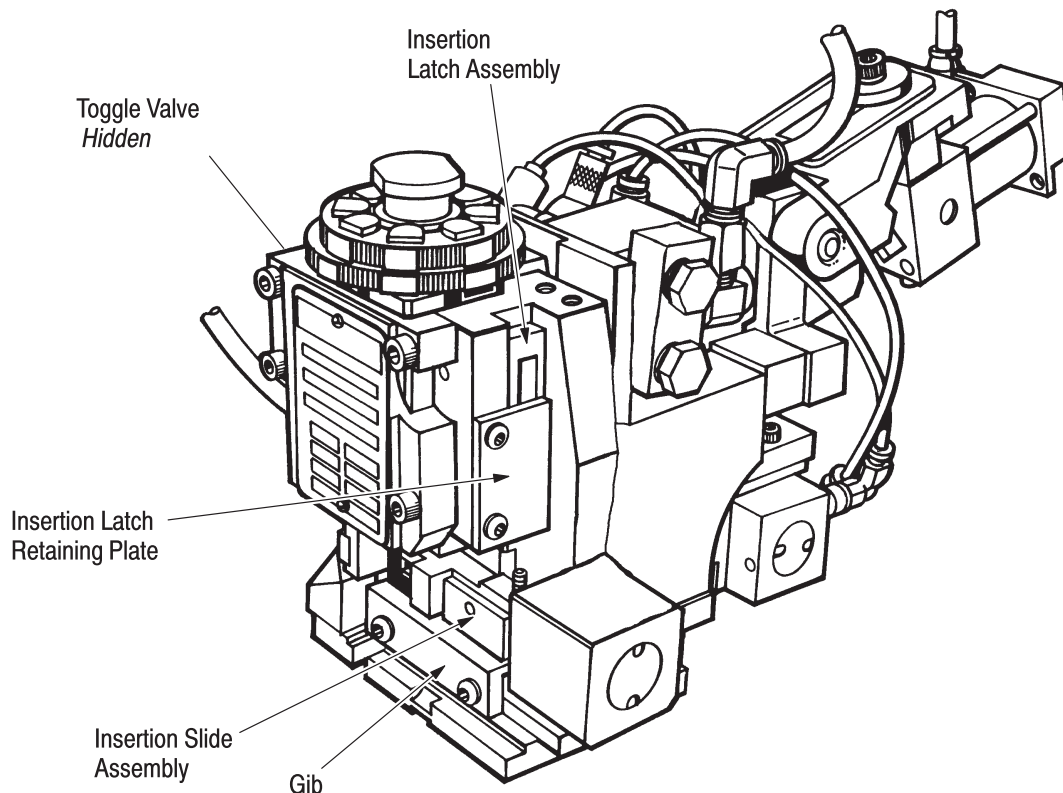

Figure 2

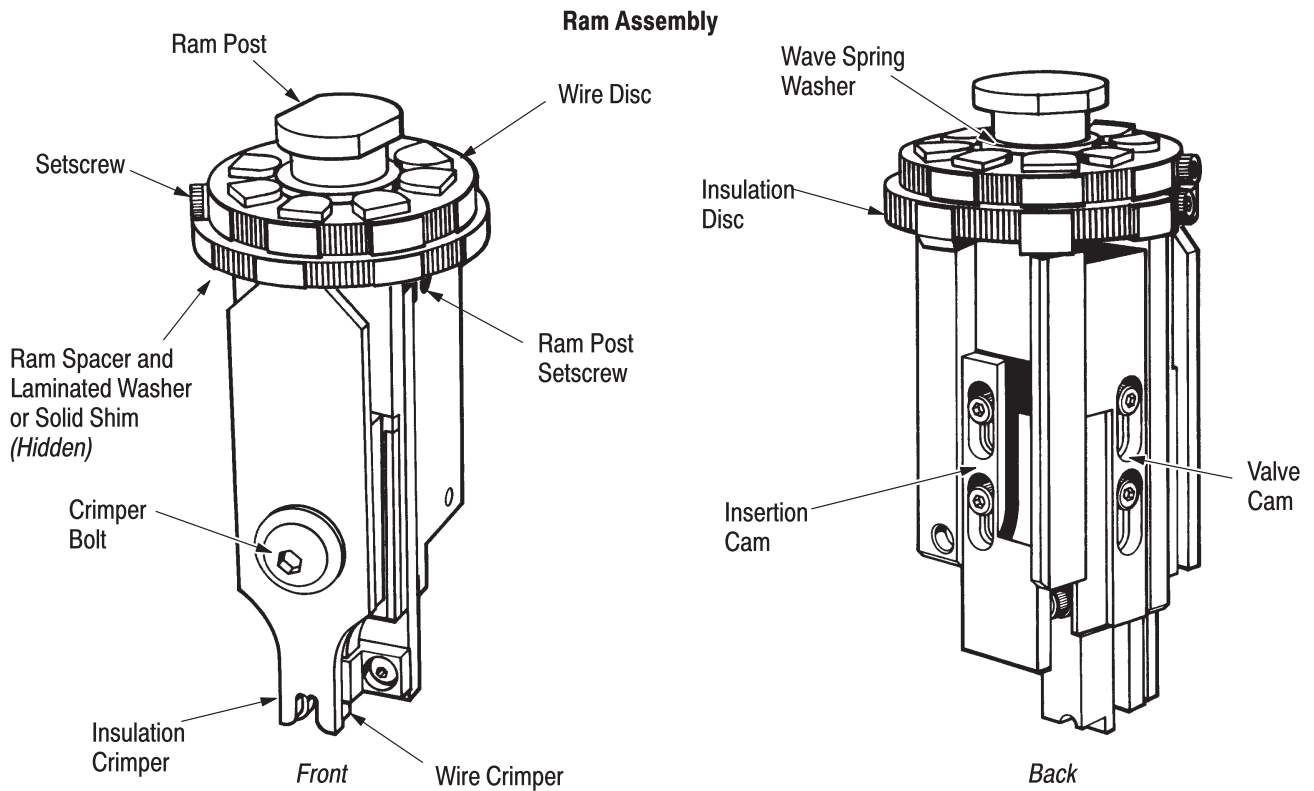

Figure 3

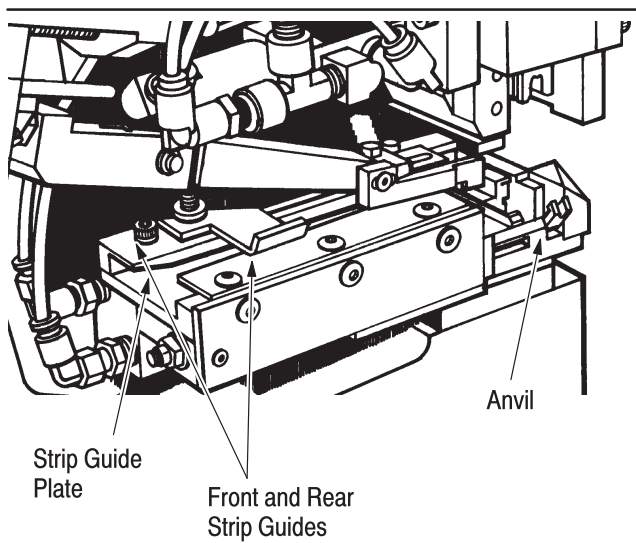

Figure 4

The top of the ram contains the ram post that connects the applicator to the ram post adapter of the machine. On the ram post is a wire disc containing up to four pairs of pads, each pair of a different height. The desired crimp height is produced by rotating the wire disc to align a pair of pads with the lobes on the bottom of the machine ram post adapter. Directly above the wire disc is a wave spring washer. Directly beneath the wire disc is a ram spacer and a

laminated washer or a solid shim. The laminated washer provides a means of fine adjustment to compensate for machining tolerances within the applicator to produce correct crimp heights in terminating units with a preset shut height.

The applicator mounting surface is the base plate which supports the lower tooling and the strip guide plate. See Figures 1 and 4 respectively.

The lower tooling comprises shear plates, the insertion slide, the anvil, stripper stop block, and the terminal back-up. See Figure 5.

3. TERMINAL STRIP LOADING AND UNLOADING



BEFORE attempting to load or unload the applicator with terminal strip, MAKE SURE the electrical power is "OFF". The air supply may remain "ON" to extend the feed cylinder.

3.1. Loading

1. Mount terminal reel on reel support. Terminal strip must unreel and enter the left end of applicator with carrier strip down and toward the back.
2. Be sure the machine ram is fully raised. If necessary, hand-cycle unit as described in applicable customer manual.

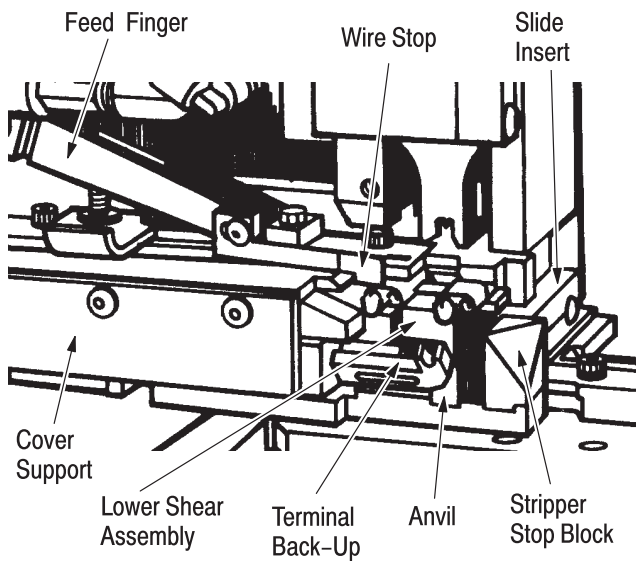

Figure 5

3. Raise terminal drag, then feed the terminal strip into the applicator between strip guides (See Figure 6).
4. Lift and hold feed finger and continue to feed terminal strip until the lead terminal is centered over the anvil. Release feed finger to engage

behind feed point in terminal strip. Release terminal drag.

5. With air pressure being applied to the feed air cylinder, pull back on the terminal strip to be sure feed point is against the feed finger.

6. Check to make sure the lead terminal is centered over the anvil. If the terminal is not centered over the anvil, make any necessary adjustments as described in Section 4, ADJUSTMENTS.

7. Adjust the applicator for proper crimp heights as specified in the applicator parts list. Follow the procedure in Paragraph 4.1 to adjust the crimp height.

3.2. Unloading (Figure 6)

1. Make sure the machine ram is fully raised. If necessary, hand-cycle as described in the appropriate customer manual.
2. Raise the terminal drag by lifting the drag lever upward.
3. Lift and hold the feed finger while pulling the terminal strip back through the strip guides.
4. After the terminal strip is out of the applicator, rewind the terminal strip onto the reel.

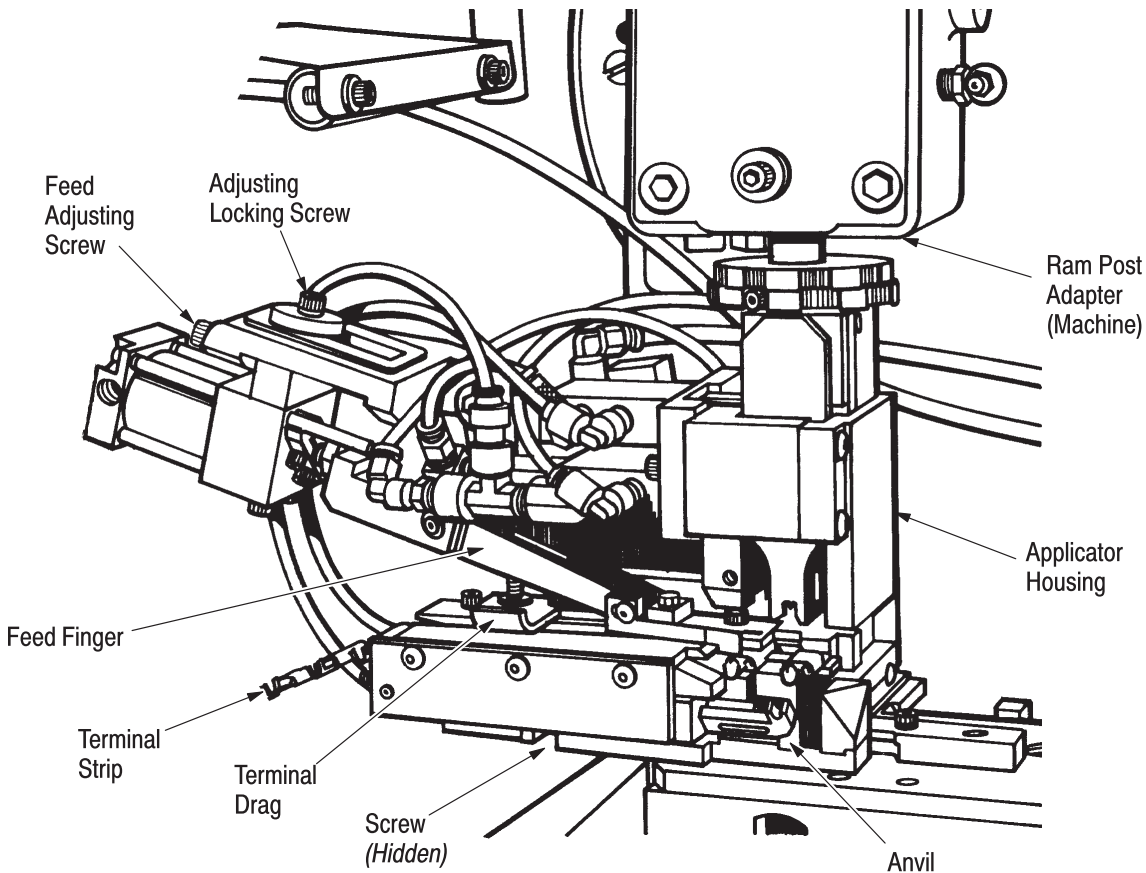

Figure 6

4. ADJUSTMENTS



BEFORE attempting any adjustments, MAKE SURE electrical power and air supply are "OFF", unless otherwise specified.

4.1. Crimp Height Adjustment (Figure 3)

1. Refer to applicator log for the settings of the wire disc. The wire disc has lettered settings (A through D) used to set the crimp heights for the different terminals and wire sizes being used.
2. Turn the wire disc to align a pair of pads (A through D) with lobes on the machine ram post adapter.
3. To check for proper height, refer to Paragraph 4.6, Wire Crimp Adjustment.

4.2. Terminal Strip Feed Adjustment (Figure 6)

1. Apply air pressure to the feed cylinder to position the lead terminal over the anvil.
2. Pull back on terminal strip to be sure feed point is against feed finger. See Figure 5.
3. If the lead terminal is not centered over the anvil, determine the direction in which the terminal must move to be centered over the anvil.
4. Loosen the adjusting locking screw on top of feed adjusting bracket.
5. Turn the feed adjusting screw until the lead terminal is centered over the anvil. To retract the terminal, pull back on the strip while making the adjustment.
6. After centering the terminal, secure the feed adjusting screw by tightening the adjustment locking screw.

4.3. Strip Guide Plate Adjustment (Figure 4 and Figure 6)

The terminal strip feed adjustment screw (Paragraph 4.2) aligns the terminal over the anvil from side-to-side. The strip guide plate adjustment aligns the terminal over the anvil from front-to-rear. If a strip guide plate adjustment (front-to-rear) is necessary, proceed as follows:

1. Slightly loosen the five screws underneath the strip guide plate adjusting block, which secures the strip guide plate to the base plate, and adjust front to back as required, with the ram DOWN.
2. After adjustment, tighten the five screws to secure guide plate to base plate.

4.4. Strip Guide Adjustment (Figure 4)

This adjustment should not be necessary unless there is a variation in the width of the terminal strip, or the front and rear strip guides are not parallel. If an adjustment must be made, proceed as follows:



DO NOT make this adjustment when front-to-rear adjustment of BOTH strip guides is required. If adjustment of both strip guides is needed, perform the procedure in Paragraph 4.3.

1. Wedge or block the feed finger so that it clears the rear strip guide. See Figure 5.
2. Determine if front or rear strip guide is to be adjusted. BOTH strip guides must be parallel with the front edge of the strip guide plate. See Figure 4.
3. Loosen screws securing strip guide to the plate.
4. Using a piece of terminal strip as a gage, adjust strip guide as required to be parallel with the other guide, and to obtain minimum clearance without binding.
5. After the adjustment is made, tighten the screws to secure the strip guide to the plate.

4.5. Slug Blade Adjustment (Figure 7)

1. With the ram bottomed, loosen the locking screws holding the slug blade (118) to the ram.
2. Adjust the blade left to right until the blade engages into the lower shear.

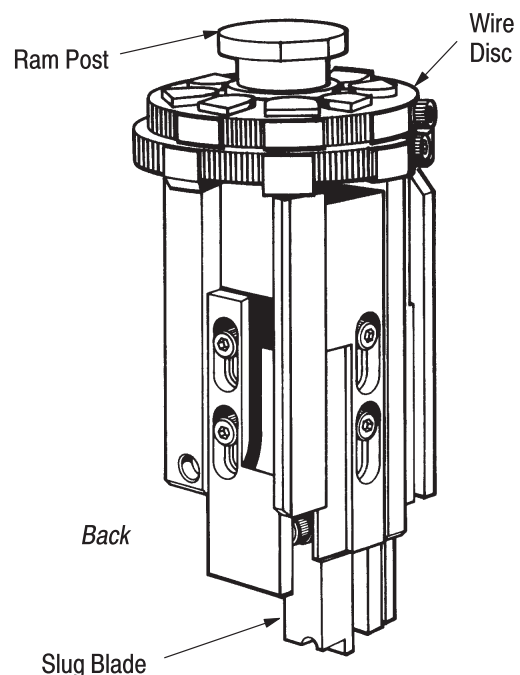

Figure 7

3. Tighten the locking screws.



BE SURE the slug blade is not bottoming on the shear plate.

4.6. Wire Crimp Adjustment

1. Refer to data plate, on applicator housing, Figure 8, and select pad letter (A, B, C, or D) for AWG wire size to be used.
2. Rotate applicator's wire disc (upper disc, See Figure 7) to align selected pad letter with bosses on machine ram (post adapter, See Figure 6). This will provide proper crimp height for that wire size.
3. After making Insulation Crimp Adjustment described in Paragraph 4.7, perform several test cycles and inspect the terminations CLOSELY for the following:
 - a. Evidence of rough and/or sharp edges (flash) around crimped barrels, deformed crimps, bent terminals, or other defects caused by worn or broken tooling. If necessary, replace tooling as described in Section 5. Refer also to Application Specification 114-2124 for inspecting crimped product.
 - b. If terminations appear normal, measure the crimp height of each termination as described in 408-7424, packaged with the applicator. Crimp heights must agree with measurement specified on parts list for the particular wire size being used. Record and retain crimp height dimensions for reference.
 - c. If crimp heights are INCORRECT, remove applicator and install an applicator that is KNOWN to produce terminations of CORRECT crimp height. Perform several test crimps and repeat step b. If crimp heights are INCORRECT for this applicator, the problem is the machine shut height, and corrective information may be obtained from the appropriate machine manual. If crimp heights are CORRECT, the problem is in the original applicator, and corrective measures are presented in Paragraph 5.5, Adjustable Crimp Height Repair.
4. During extensive operation, periodically repeat Step 3 to ensure that applicator is producing correct terminations.

4.7. Insulation Crimp Adjustment (Figure 9)

To adjust the insulation crimp height, rotate the applicator's insulation disc (lower disc) to align the number (1 through 8) with the top of the insulation adjustment block on the ram assembly. The tightest crimp is made by No. 8, and the loosest by No. 1, a

difference of approximately 1.78 mm [.070 in.], providing a wide variation.

To find the desired insulation crimp, start with No. 1 and make test crimps, increasing the setting one number at a time until the proper insulation crimp height is obtained.

5. REPAIR AND REPLACEMENT

The following procedures cover applicator parts which most often require repair or replacement because of wear. They are recommended spares which are the customer's responsibility to stock and replace. Refer to the applicator parts lists packaged with the applicator.



Remove the applicator from the unit, as described in Paragraph 4 of AI 8022 (also referred to as 408-8022), BEFORE making repairs or replacing parts. AFTER repair or replacement, BE SURE all adjustments are correct, as described in Section 4 of this document, before attempting operation.

5.1. Wire Crimper Replacement (Figure 3)

1. Remove the ram assembly by lifting the ram up and out.
2. Remove the crimper bolt holding the insulation crimper, crimper spacers, and wire crimper to the ram. Note the orientation of parts for replacement purposes.
3. Install new wire crimper and/or other parts removed, by reversing the removal procedure. BE SURE part numbers of new parts agree with the part numbers on the parts lists. DO NOT tighten the crimper bolt at this time.
4. To align the wire crimper with the anvil, place a piece of heavy paper over the anvil, install the ram into the applicator housing, and push the ram DOWN over the anvil. This forces the crimper to align with the anvil. When the ram is bottomed, tighten the crimper bolt to secure the wire crimper, spacers, and insulation crimper to the ram.

5.2. Anvil Replacement (Figure 6)

1. From the bottom of the applicator base plate, remove the screw securing the anvil to the base plate.
2. Remove the anvil from the base plate.
3. Install the new anvil using the reversed procedure. Be sure the part number of the anvil agrees with the part number on the parts lists.
4. Check the alignment of the crimper with the anvil as described in Paragraph 5.1, and make any necessary adjustments.

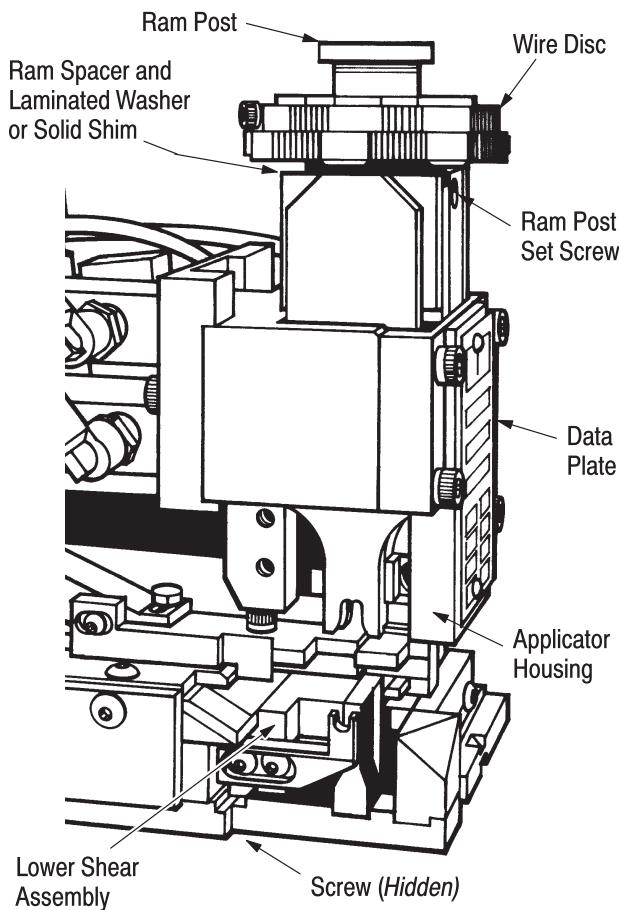

Figure 8

5.3. Slug Blade Replacement (Figure 7)

1. Lift the ram assembly (or remove the ram assembly if it is more convenient).
2. Remove the two screws securing the slug to the ram.
3. Install the new slug blade by reversing the removal procedure. BE SURE the part number agrees with the part numbers on the parts list.

5.4. Shear Plate Replacement (Figure 8)

1. Lift the ram assembly (or remove the ram assembly if it is more convenient).
2. Remove the five screws under the base plate and remove the strip guide plate. See Figure 3.
3. Remove the screw securing the lower shear assembly to strip guide plate. See Figure 8.
4. Slide out the shear plates.
5. Install the new shear plate by reversing the removal procedure. BE SURE the part number agrees with the part numbers on the parts list.

NOTE



The shear plate fits against the housing and cannot be adjusted.

5.5. Adjustable Crimp Height Repair (Figures 8 and 9)

Under the disc and the ram spacer is a laminated washer or a solid shim which may break or compress, causing the applicator to produce terminations with a different crimp height than specified for the setting of the wire disc. To correct this problem, proceed as follows:

1. Subtract the specified crimp height from the average crimp height recorded in Paragraph 4.6. This dimension will be the thickness of washer(s) (PN 690125-1) to be ADDED under the ram spacers.

NOTE



Washer 690125-1 is a peel-type, laminated washer consisting of five layers, each layer being 0.05 mm [.002 in.] thick.

2. Remove the applicator from the unit.
3. Remove ram assembly from applicator housing by pulling upward.
4. Loosen setscrew in side of ram securing ram post, then turn ram upside down and secure ram post in a vise.
5. Unscrew ram from ram post, leaving ram spacer and wire disc on ram post.

CAUTION



If ram spacer and wire disc are removed from ram post, detent ball and spring will pop out and may become lost.

6. Measure thickness of old laminated washer or the solid shim after removal from ram post, using a micrometer. ADD this thickness to the thickness determined in step 1. The total is the thickness required for the new washer.
7. Install new washer on ram post, then install ram. Tighten ram until snug, then check that numbers on wire disc align with center of ram sides. If not, turn ram back slightly until they do align, then tighten setscrew to secure ram post.
8. Remove ram assembly from vise, then turn wire disc to other positions to check numbers for centering on sides of ram.
9. Install ram assembly in applicator housing, and install applicator in the unit. Make some test crimps under power, then measure crimp heights of terminations. If crimp heights are within specified tolerances, applicator may be placed in service. If not, repeat the procedure.

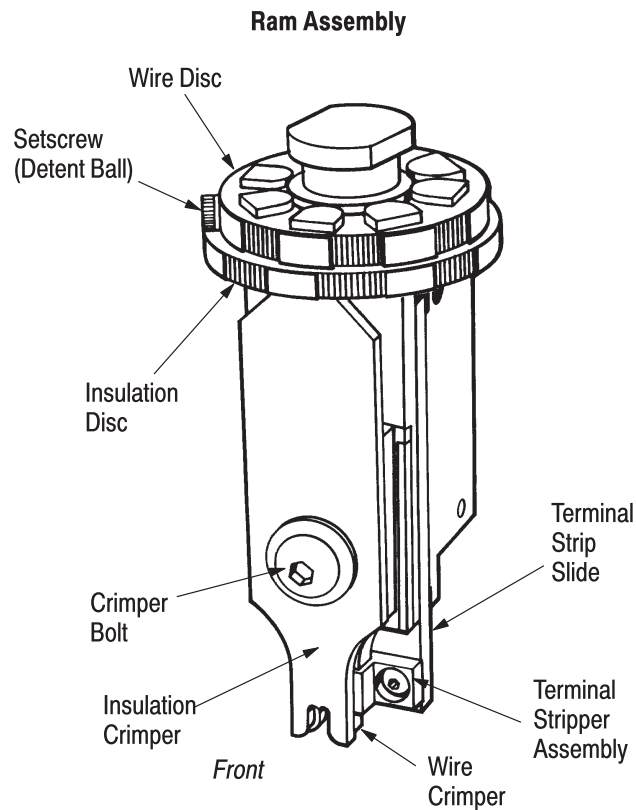

Figure 9

6. CLEANING AND LUBRICATION

For optimum performance and minimum downtime, the applicator should be cleaned and lubricated after each eight hours of operation, and each time it is removed from the unit to be placed in storage.



DANGER Disconnect electrical power and air supply when performing maintenance, lubrication, inspection, and repairs.

6.1. Cleaning

1. Remove the applicator from the unit as described in Paragraph 4 of 408-8022 .
2. Remove the ram assembly from the applicator as described in Paragraph 5.1.
3. Using a clean cloth or air hose, remove all evidence of dirt and foreign matter. If desired, the entire ram may be immersed in a suitable commercial solvent (one that will not affect paint or plastic) to flush out dirt, chips, etc, then dried with an air hose or clean cloth.

DANGER



Compressed air used for cleaning must be reduced to less than 207 kPa [30 psi], and effective chip guarding and personal protective equipment (including eye protection) must be used.

4. Lubricate the applicator as described in Paragraph 6.2, before installing the ram assembly.

6.2. Lubrication

The applicator is to be lubricated at the following points using SAE 20 motor oil (non-detergent) or light grease.

CAUTION



DO NOT use an excessive amount of lubricant. Any excess MUST be removed. Avoid lubricant around the wire disc.

1. Apply a few drops of oil to all pivot points.
2. Apply a thin film of grease to the four corners of the ram or the applicator housing for the ram assembly, and to the transfer slide tracks.
3. Apply a small amount of grease in the cam tracks on the applicator.
4. Install the ram assembly in the applicator housing, then remove any excess grease or oil.

7. APPLICATOR STORAGE

1. Rather than remove the terminal strip from the applicator, cut the terminal strip several terminals away from the point of entry into the strip guides. This will leave a sample of the type terminals used in the applicator when it is returned to service.
2. Remove the applicator from the unit as described in Paragraph 4 of 408- 8022.
3. Clean and lubricate the applicator as described in Section 6.
4. Bottom the ram assembly to retain lead terminal between crimpers and anvil. Store in a clean, dry area.

8. REVISION SUMMARY

Since the previous release of this document, the following changes have been made.

- Updated document to corporate requirements, including current logo
- Removed reference to Model I CLS machine