

AUTOMATIC MACHINE DIVISION

1. Each MATE-N-LOK Connector consists of two Housings (a Plug and a Cap) and Pin and Socket Contacts. The Cap accepts Pin Contacts. The Plug accepts Socket Contacts. See Figure 1.

2. CONTACT CRIMPING

Crimp Contacts using:

- (a) The proper A-MP Auto-Machine Applicator according to the AMP Instruction Manual shipped with the Applicator.
- (b) The Hand Tools and Instruction Sheets listed in Figure 2.

3. CONTACT INSERTION

NOTE: Use Pins only in Cap. Use Sockets only in Plug.

(a) For single-wire leads, push Contact into Housing as far as it will go. See Figure 1. Pull back lightly on Wire to make sure Contact is latched in place.

(b) For two-wire leads, first align Contact with Cavity as shown in Figure 3. Then push Contact into Housing and check to make sure it is properly inserted.

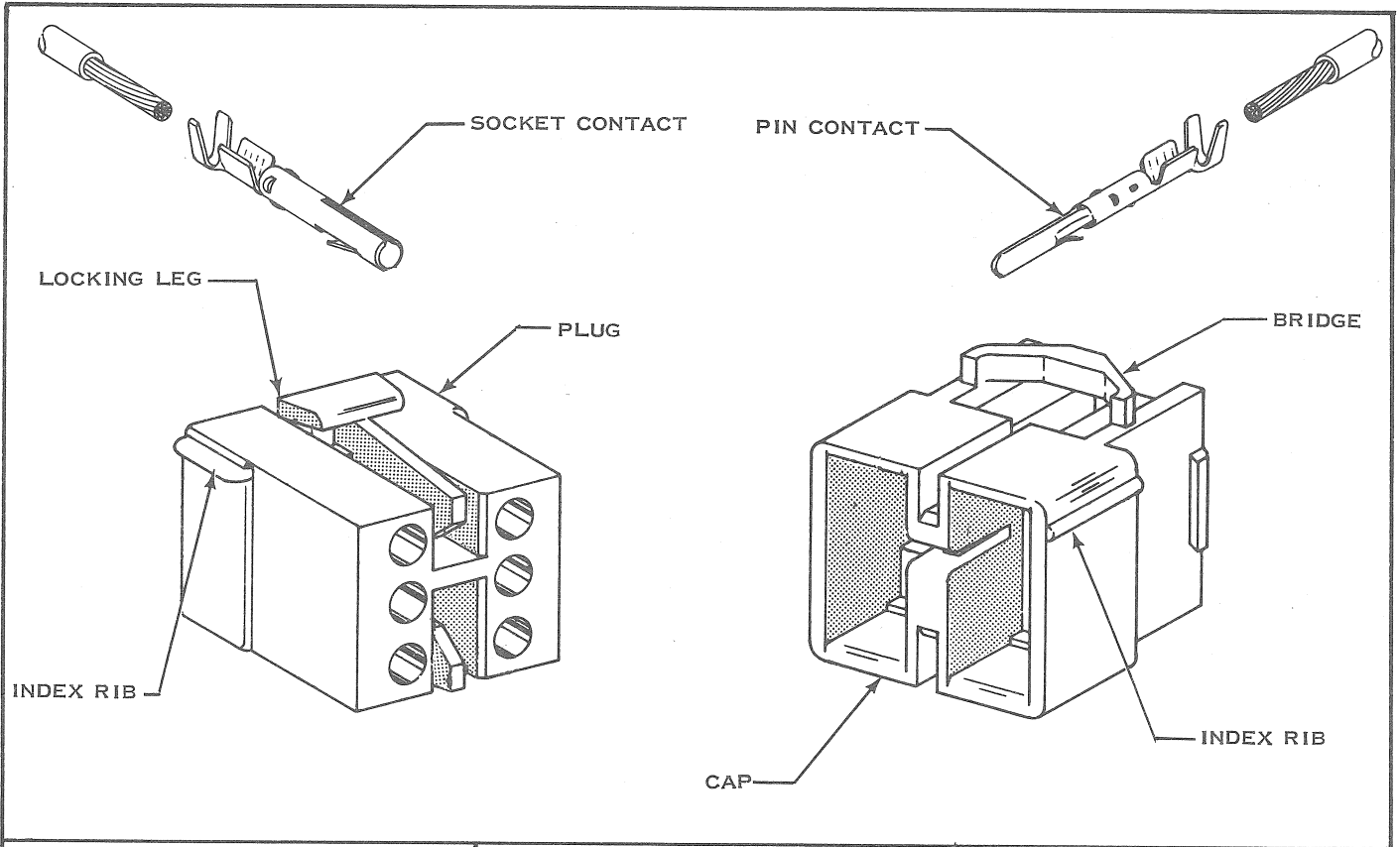

© 1965 by AMP Incorporated. All international rights reserved. A-MP products covered by U. S. and foreign patents and/or patents pending.

NUMBER OF CIRCUITS	PLUG NUMBER	CAP NUMBER
6	480270	480340
8	480283	480345
10	480285	480339

*Trademark of AMP Incorporated

FIG. 1

SOCKET NUMBER		PIN NUMBER		TOOL NUMBER	INSTRUCTION SHEET NO.
STRIP	LOOSE PIECE	STRIP	LOOSE PIECE		
60510	60617	60511	60618	90123	7159
60527	60619	60528	60620	90124	
60496	60615	60497	60616		

FIG. 2

NOTE: Two-wire leads may be used only in Socket Contacts.
 (c) When inserting Contacts crimped to small flexible Wire, use A-MP Insertion Tool No. 91002.

(b) To disengage Housings, squeeze Locking Legs together and pull Plug out of Cap. See Figure 4.

4. HOUSING ENGAGEMENT & DISENGAGEMENT

(a) To mate Housings, align Index Ribs on Plug and Cap and push Plug into Cap until Locking Legs on Plug engage Cap. See Figure 4.

5. CONTACT EXTRACTION

To remove Contacts from Housings, use A-MP Extraction Tool No. 1-305183-1 for Pin Contacts and No. 1-305183-2 for Socket Contacts. See AMP Instruction Sheet No. 7158.

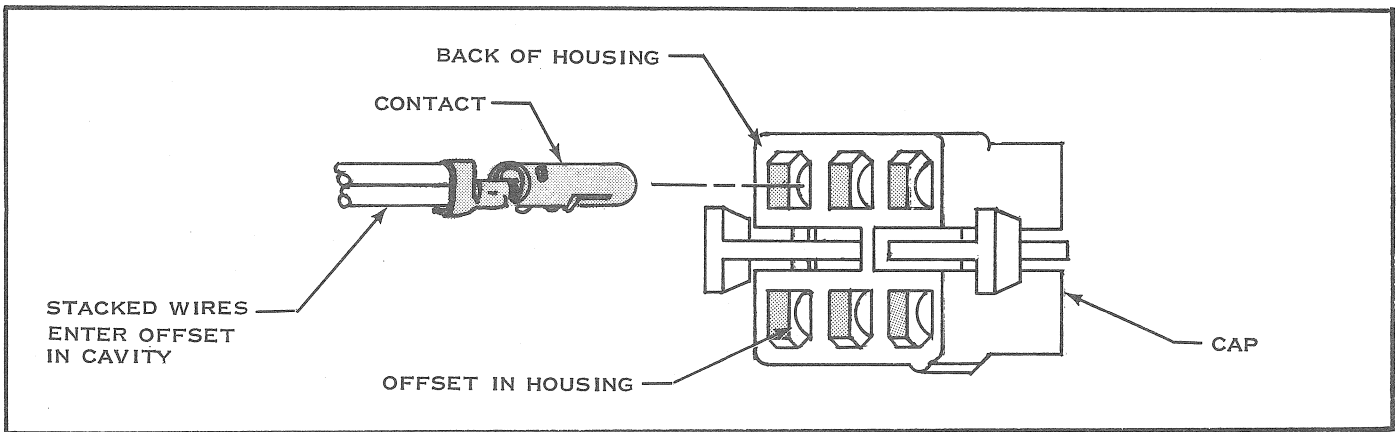

FIG. 3

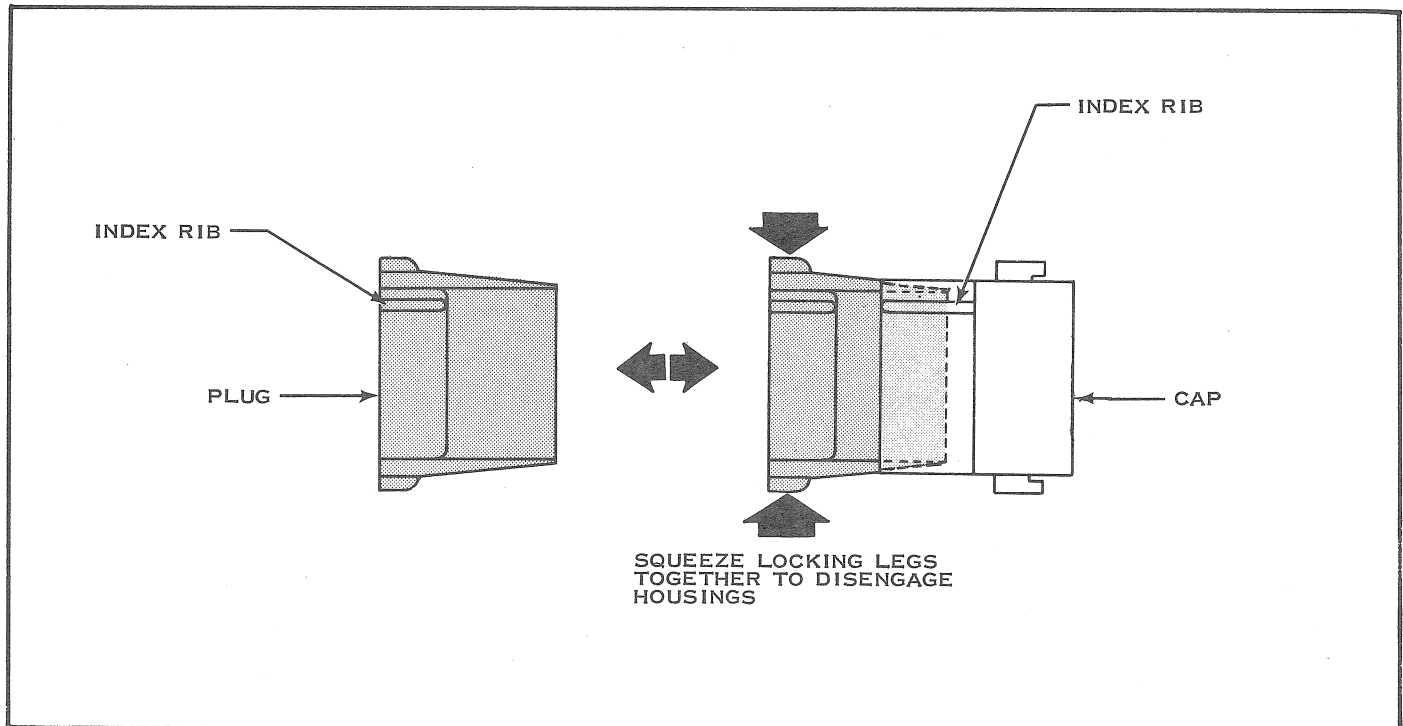

FIG. 4