

HVSA-3-1580S

15kV Class

Transition Splice for 3/C PILC to
3/C Armored Extruded Dielectric (Poly/EPR) Power Cables

ENERGY DIVISION

Suggested Installation Equipment (not supplied with kit)

- Cable preparation tools
- Tyco Electronics P63 cable preparation kit or cable manufacturer approved solvent
- Clean, lint-free cloths
- Non-conducting abrasive cloth, 120 grit or finer
- Electrician's tape
- Connector(s) and installation tools
- Tyco Electronics recommended torch

Safety Instructions

DANGER: When installing electrical power system accessories, failure to follow applicable personal safety requirements and written installation instructions could result in fire or explosion and serious or fatal injuries.

To avoid risk of accidental fire or explosion when using gas torches, always check all connections for leaks before igniting the torch and follow the torch manufacturer's safety instructions.

To minimize any effect of fumes produced during installation, always provide good ventilation of confined work spaces.

As Tyco Electronics has no control over field conditions which influence product installation, it is understood that the user must take this into account and apply his own experience and expertise when installing product.

Customer Service

For 24 hour customer service, call 800-327-6996.

Recommended Tyco Electronics Torches

Install heat-shrinkable cable accessories with a "clean burning" torch, i.e., a propane torch that does not deposit conductive contaminants on the product.

Clean burning torches include the Tyco Electronics FH-2629, FH-2649 (uses refillable propane cylinders) and FH-2618A (uses disposable cylinder).

Adjusting the Torch

Adjust regulator and torch as required to provide an overall 12-inch bushy flame. The FH-2629 will be all blue, the other torches will have a 3- to 4-inch yellow tip. Use the yellow tip for shrinking.

Regulator Pressure

FH-2618A	Full pressure
FH-2649	25 psig
FH-2629	15 psig

Cleaning the Cable

Use an approved solvent, such as the one supplied in the P63 Cable Prep Kit, to clean the cable. Be sure to follow the manufacturer's instructions. Failure to follow these instructions could lead to product failure.

Some newer solvents do not evaporate quickly and need to be removed with a clean, lint-free cloth. Failure to do so could change the volume resistivity of the substrate or leave a residue on the surface. Please follow the manufacturer's instructions carefully.

General Shrinking Instructions

- Apply outer 3- to 4-inch tip of the flame to heat-shrinkable material with a rapid brushing motion
- Keep flame moving to avoid scorching
- Unless otherwise instructed, start shrinking tube at center, working flame around all sides of the tube to apply uniform heat

To determine if a tube has completely recovered, look for the following, especially on the back and underside of the tube:

1. Uniform wall thickness
2. Conformance to substrate
3. No flat spots or chill marks
4. Visible sealant flow if the tube is coated

Note: When installing multiple tubes, make sure that the surface of the last tube is still warm before positioning and shrinking the next tube. If installed tube has cooled, re-heat the entire surface.

Installation Instructions

1. Product selection

Check kit selection with cable diameter dimensions in Table 1.

Note: Table is for 100% insulated Poly cable. For 133% insulated cable, check actual cable dimensions.

Table 1 Kit	PILC/Poly Nominal Cable Range	PILC Insulation Diameter Range	Poly Insulation Diameter Range	Maximum Connector Dimensions	
				Length	Diameter
HVSA-3-1581S	#4-4/0	0.60-1.00 (15-25mm)	0.65-1.05 (17-27mm)	4.5 (115mm)	0.90 (23mm)
HVSA-3-1582S	4/0-350	0.85-1.10 (22-28mm)	0.90-1.30 (23-33mm)	5.5 (140mm)	1.15 (29mm)
HVSA-3-1583S	500-750	1.05-1.50 (27-38mm)	1.10-1.60 (28-41mm)	7.0 (178mm)	1.60 (41mm)
HVSA-3-1584S	750-1000	1.15-1.75 (29-44mm)	1.25-1.80 (32-46mm)	8.0 (203mm)	1.85 (47mm)

2. Check ground braid

Verify that ground braid(s) or bond wire have equivalent cross-section to cable metallic shield. Additional braid may be needed for LC shield, lead sheath cables, or if external grounding or shield interrupting is required.

Raychem HVS-EG supplies ground braid, spring clamp and suggested modifications to make an external ground or shield interrupt.

3. Prepare cables

Choose the cable type (Choice 1-3) and use the dimensions shown in Table 2 to prepare the cables.

Table 2 Kit	Jacket Cutbacks		Metallic Shield Cutback/ Wire Pullback B	Semi-con Cutback C
	A1	A2		
HVSA-3-1581S	34" (863mm)	19" (483mm)	9" (229mm)	5-1/2" (115mm)
HVSA-3-1582S	33" (838mm)	20" (508mm)	10" (254mm)	6" (152mm)
HVSA-3-1583S	39" (990mm)	22" (559mm)	11" (279mm)	7" (178mm)
HVSA-3-1584S	38" (965mm)	23" (584mm)	12" (305mm)	7-1/2" (190mm)

Choice 1

If Metallic Tape Shield Cable

Refer to Table 2 and prepare the cables as shown. Remove any fillers to the armor cutback. Bend back the grounding conductor(s) over the jacket as shown.

Go to Step 4, page 3.

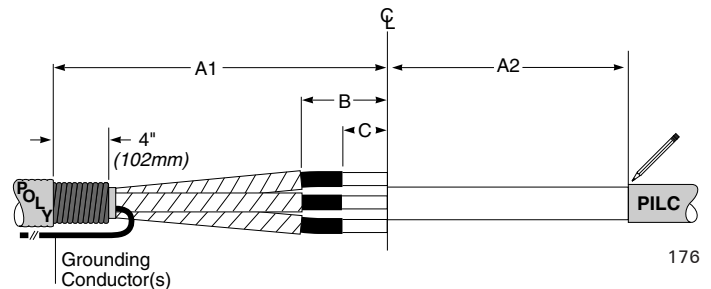

Choice 2

If Drain Wire Shield Cable

Refer to Table 2 and prepare the cables as shown. Remove any fillers to the armor cutback. Pull drain wires back to Dimension B and temporarily tape over ends as shown. Bend back the grounding conductor(s) over the jacket as shown.

Go to Step 4 below.

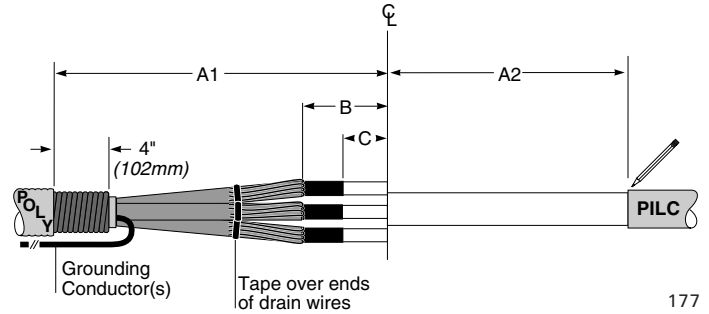

177

Choice 3

If UniShield* Cable

Refer to Table 2 and prepare the cables as shown. Remove any fillers to the armor cutback. Pull drain wires back to Dimension B and temporarily tape over ends as shown. Bend back the grounding conductor(s) over the jacket as shown.

Go to Step 4.

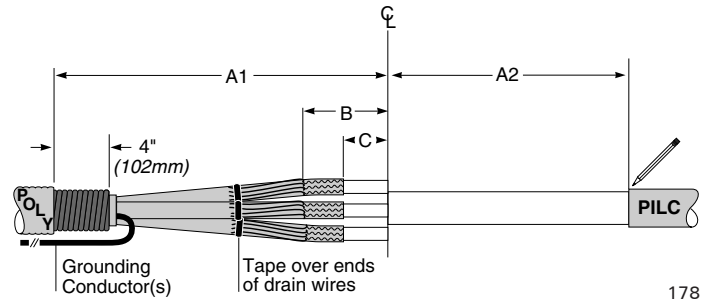

178

*UniShield is a trademark of General Cable Technologies Corporation

4. Prepare lead sheath

Abrade the lead sheath and clean with oil-free solvent as shown.

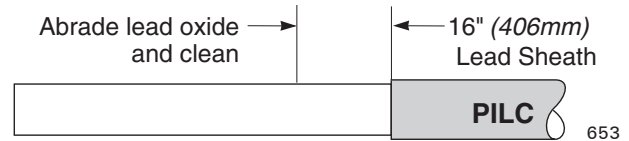

653

5. Remove lead sheath as shown

Kit	Lead Sheath Cutback G
HVSA-3-1581S	14" (356mm)
HVSA-3-1582S	15" (381mm)
HVSA-3-1583S	16" (406mm)
HVSA-3-1584S	17" (432mm)

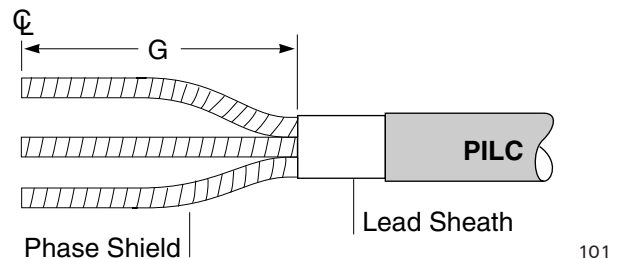

101

6. Cut back shield or belt papers

Choose the cable type (choice 1 or 2) and follow the directions given.

Choice 1

If Shielded PILC Cable

Cut back any bedding and/or shielding tapes over all three phases to lead sheath cutback. Cut back phase shields and remove any conductive material from paper insulation as shown.

Tack solder metal tape shields to prevent unwrapping and tape over sharp edges with one wrap of electrician's tape.

Go to Step 7 page 4.

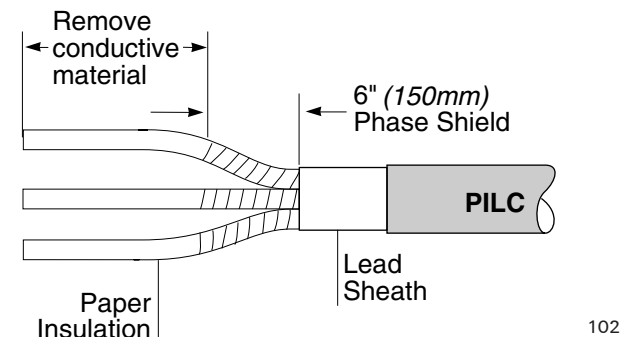

102

Choice 2

If Belted PILC Cable

Remove belt papers as shown.

Go to Step 7.

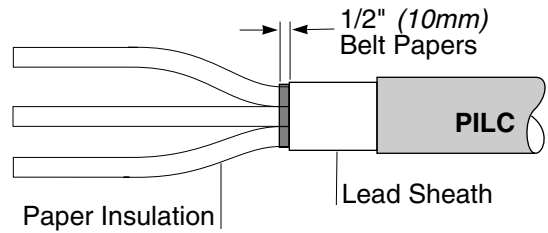

103

7. Mark insulation as shown

Kit	H
HVSA-3-1581S	3-1/2" (89mm)
HVSA-3-1582S	4" (102mm)
HVSA-3-1583S	5" (127mm)
HVSA-3-1584S	5-1/2" (140mm)

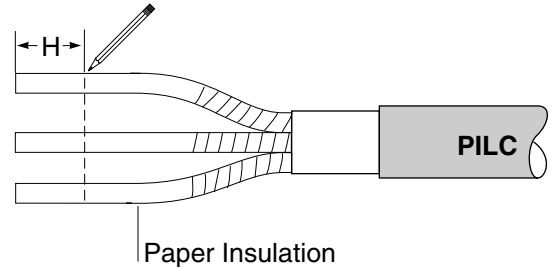

104

8. Apply Stress Relief Material (SRM)

Remove backing strip from one side of a long strip of SRM. Roll up the SRM and remaining backing strip into a convenient size.

Removing the remaining backing strip, tightly wrap one, half-lapped layer of SRM around each phase as shown. Wrap SRM in same direction as insulating papers on cable.

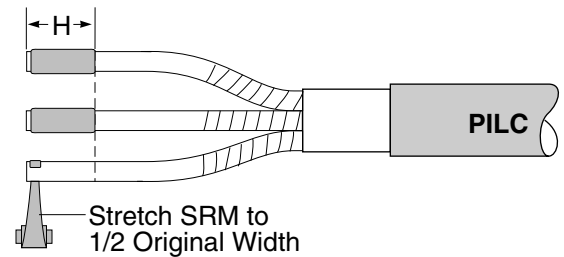

105

9. Position OBT; shrink in place

Place an Oil Barrier Tube (OBT) over each phase, butted to the lead sheath (or belt paper) cutback. Shrink the three OBTs in place starting at the lead sheath cutback.

Note: To achieve a smooth, wrinkle-free installation, use a reduced flame to install the thin-walled OBT.

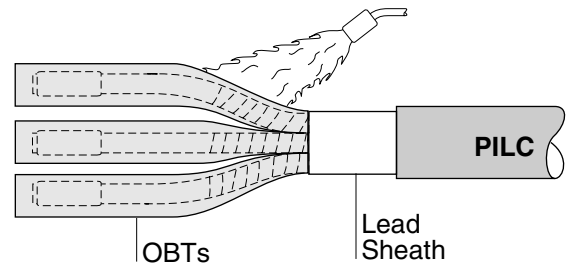

394

10. Inspect OBTs

The installed OBTs should have a smooth, wrinkle-free surface after shrinking. Reheat to smooth any wrinkled areas.

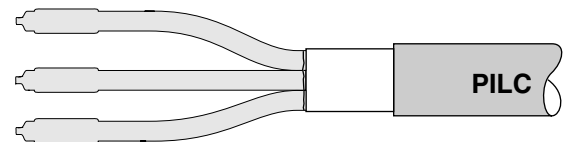

395

11. Install 1" wide copper mesh

If Belted PILC Cable...Discard 1" wide copper mesh. **Go to Step 12.**

If Shielded PILC Cable...follow directions below.

Fold the 1 inch (25mm) wide copper mesh in half lengthwise.

Wind mesh around each phase shield as closely as possible to the lead sheath cut.

Solder copper mesh to the lead sheath. Cut off excess mesh close to lead sheath.

Go to Step 12.

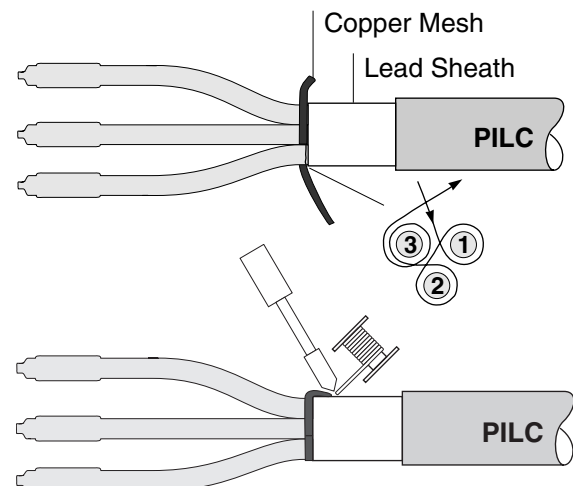

290

207

12. Mark OBT/ Insulation at "I"

Kit	I
HVSA-3-1581S	6-1/2" (165mm)
HVSA-3-1582S	7" (178mm)
HVSA-3-1583S	8" (203mm)
HVSA-3-1584S	8-1/2" (216mm)

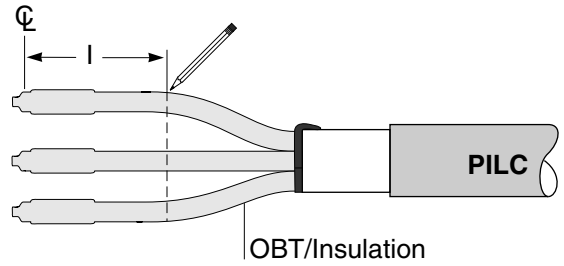

220

13. Position black conductive tubes; shrink in place

Place black conductive tube over each phase and position at dimension "I".

Shrink in place starting at the end nearest to the center of the splice.

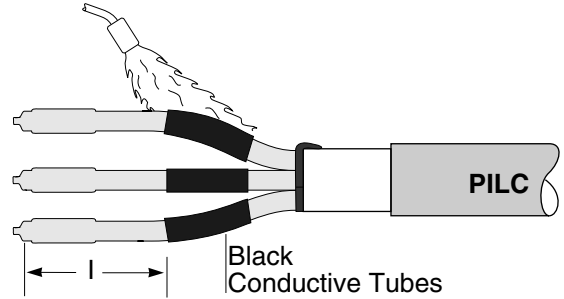

221

14. Clean OBTs

Using an approved solvent, clean the OBT/Insulation, as shown.

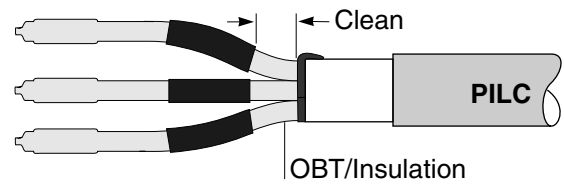

222

15. Install SRM insert

Assemble SRM insert per box instructions. Spread the phases and position the insert as shown.

Note: The SRM insert is packaged inside the conductive breakout.

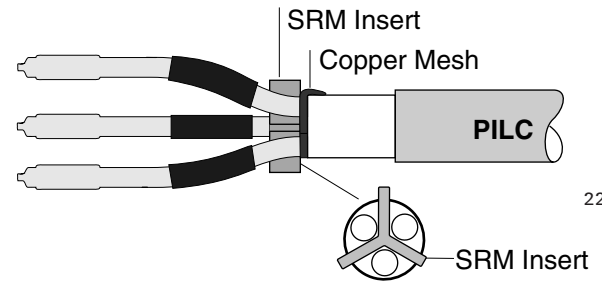

223

16. Trim excess SRM insert

Trim SRM insert to extend 1/8" (3mm) beyond each phase.

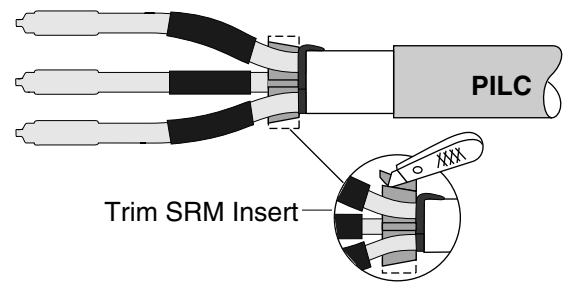

224

17. Clean lead sheath

Reclean lead sheath as shown using an approved solvent.

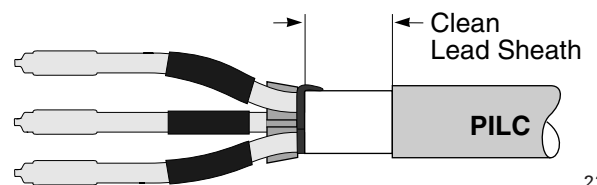

225

18. Mark lead sheath as shown

Note: To ensure SRM to OBT adhesion, gently heat the SRM insert and adjacent OBT before moving on to the next step.

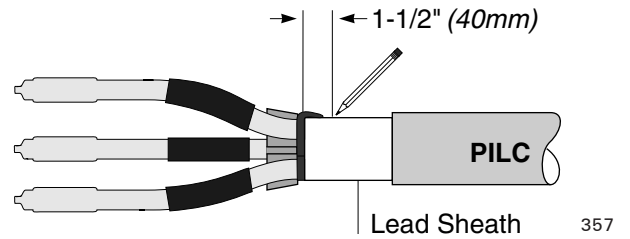

19. Install oil seal

Remove backing from one side of a long strip of SRM. Roll the SRM and remaining backing strip into a convenient size. Removing the remaining backing strip, tightly wrap the SRM from the mark on the lead sheath to the outer edge of the SRM insert. Four to six strips of SRM should be used to build the SRM to the shape shown.

Note: Do not over apply. The finished SRM diameter should not exceed that of the breakout installed in the next step.

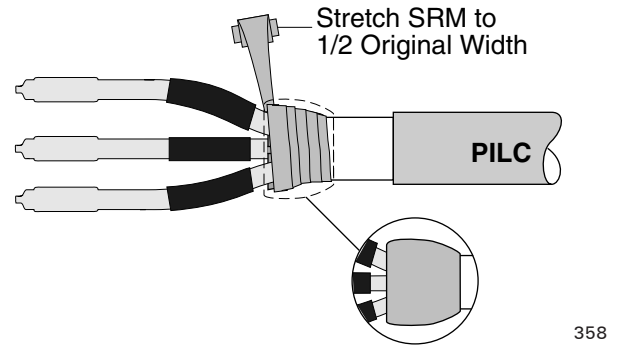

20. Position conductive breakout; shrink in place

Position the conductive breakout over the SRM so that the inside butts up hard against the SRM.

Shrink in place starting at the fingers and working toward the other end.

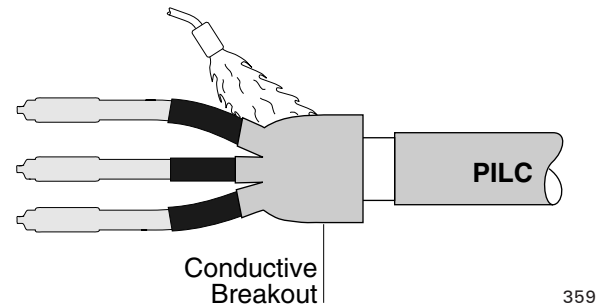

21. Inspect breakout

After the breakout has shrunk, continue to apply heat until the breakout has a smooth, uniform surface.

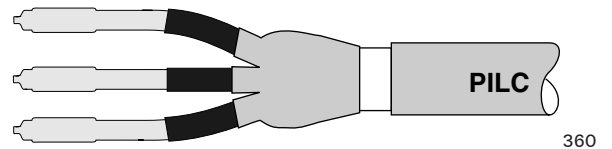

22. Clean cables; position splice components

Abrade insulation, if necessary, to remove imbedded semi-con. Clean Poly cable jackets for 30" (760mm).

Place one set of nested tubes over each clean Poly cable.

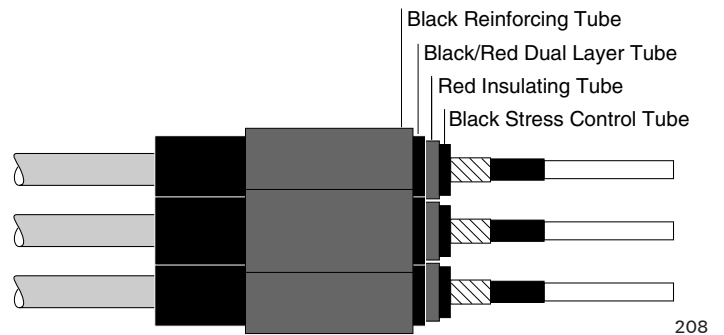

23. Remove insulation

Refer to Table 5 and cut back the insulation as shown.

Table 5: Connector Dimensions

Kit	Max Length	Max O.D.	Expansion Gap "X"
HVSA-3-1581S	4-1/2" (114mm)	0.90" (23mm)	1/4" (5mm)
HVSA-3-1582S	5-1/2" (140mm)	1.15" (29mm)	1/4" (5mm)
HVSA-3-1583S	7" (178mm)	1.60" (41mm)	1/2" (10mm)
HVSA-3-1584S	8" (203mm)	1.85" (47mm)	1/2" (10mm)

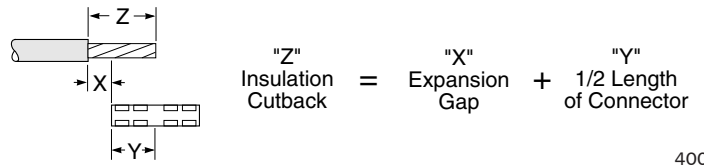

400

24. Install connectors

Make sure connector has center oil stop.

After installation, deburr connections.

Note: A Poly tape shield to PILC splice is shown in this instruction as an example. Any cable combination discussed earlier can be used.

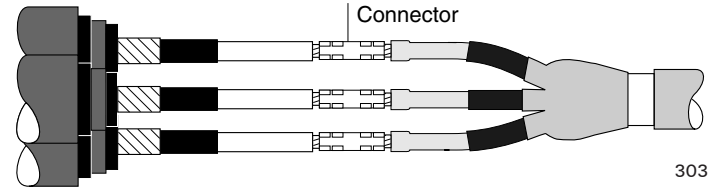

25. Clean connector area

Complete Steps 25-29 working on one phase at a time.

Using an approved solvent, clean the insulation as shown, paying particular attention to the OBT/insulation surface.

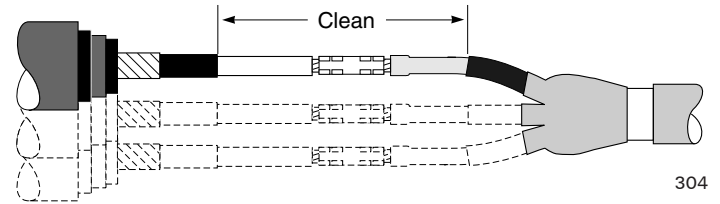

26. Apply SRM over connector

Remove backing from one side of a long strip of SRM. Roll the SRM and remaining backing strip into a convenient size. Removing the remaining backing strip, tightly wrap the SRM around the connector and exposed conductor. Be sure to fill the gaps and low spots around the connector.

Continue to wrap the SRM onto the insulation as shown.

Note: If the connector diameter is larger than the insulation diameter, apply two half-lapped layers of SRM over the entire connector. Discard any excess SRM (long strips).

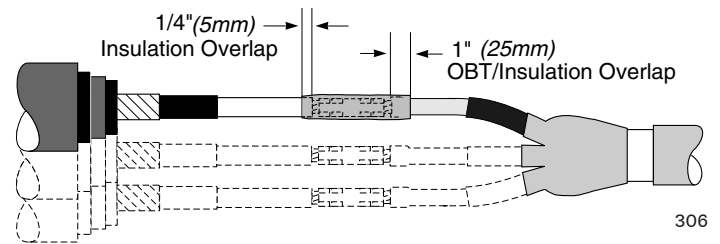
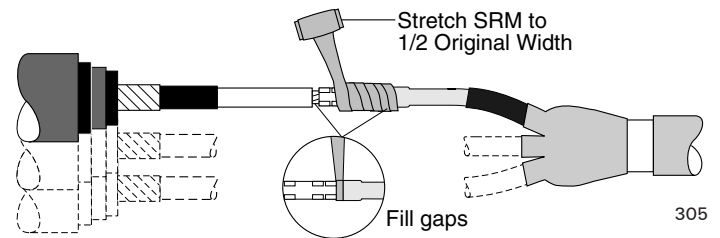

27. Apply SRM at black conductive tube step

Remove backings from the short angle-cut piece of SRM. Place tip of SRM at black conductive tube step and tightly wrap to fill the step. Overlap black conductive tube and OBT/Insulation and taper down to meet OBT insulation as shown.

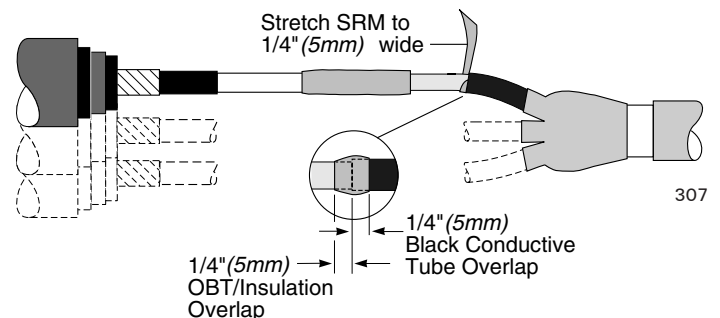

28. Apply SRM at semi-con cutback

Remove backings from the short angle-cut piece of SRM. Place tip of SRM at semi-con step and tightly wrap to fill the step. Overlap semi-con and insulation and taper down to meet insulation as shown.

Note: If using UniShield* cable, apply SRM as shown to fill conductive jacket step.

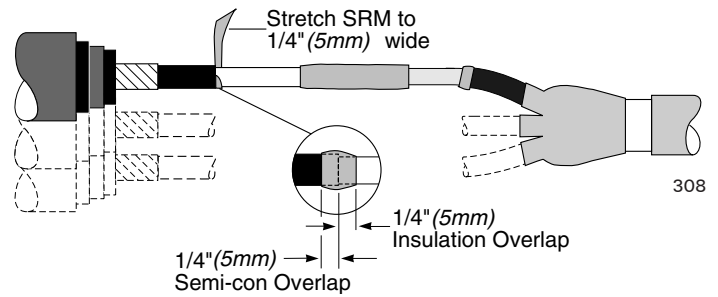

*UniShield is a trademark of General Cable Technologies Corporation

29. Apply Discharge Control Compound (DCC)

Snip open the end of the DCC ampule and apply a thin film of compound over the three applications of SRM.

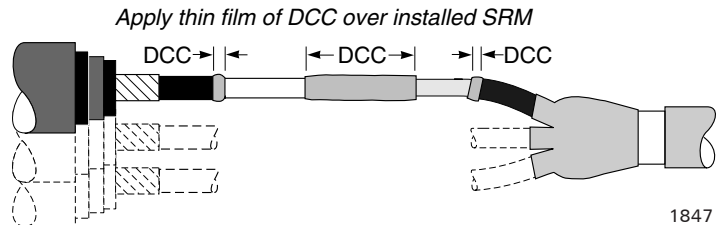

30. Position black stress control tube

Center black stress control tube over the completed connector area. Be sure to equally overlap the Poly cable semi-con and the PILC cable black conductive tube.

Repeat Steps 25-30 for the remaining two phases.

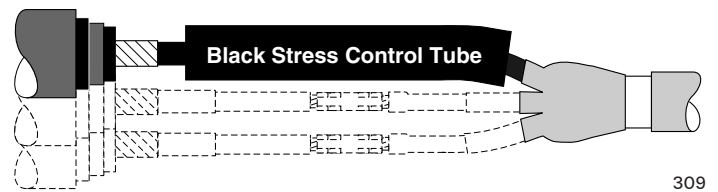

31. Check position of black stress control tubes; shrink in place

Center the tubes over the splice. Begin shrinking at the center (1) of the tubes, working the torch around all sides of the tubes. After the center portion shrinks, work towards one end (2), then to the opposite end (3).

Note: Do not point the flame at the cable semi-con.

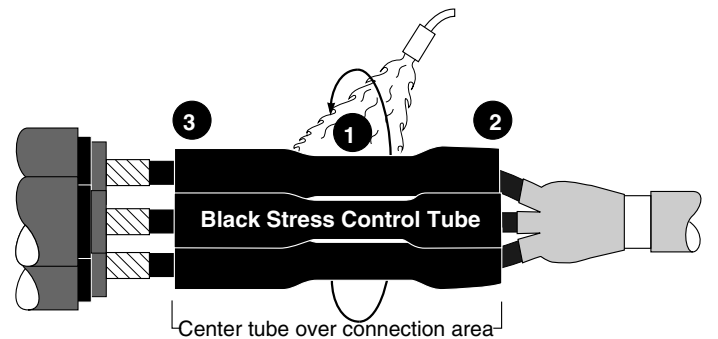

The rings from the SRM wraps may be visible as the tubing shrinks.

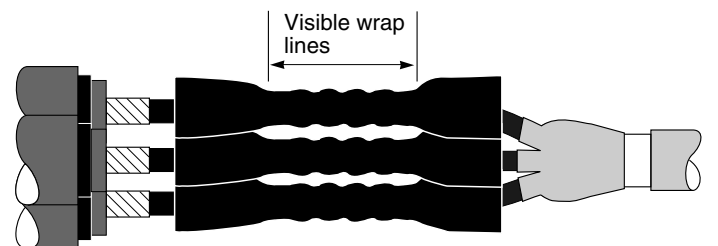

Post heat the connector area until the tube surface is smooth and the underlying SRM wraps are no longer visible.

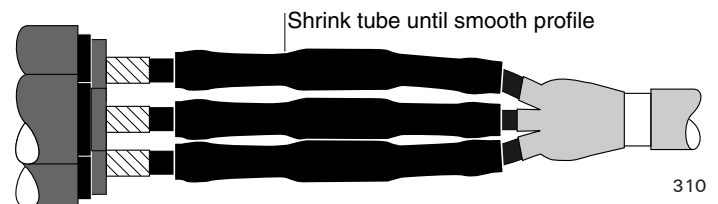

32. Position red insulating tubes; shrink in place

Center tubes over the black stress control tubes. Shrink in place using the same method as in Step 31.

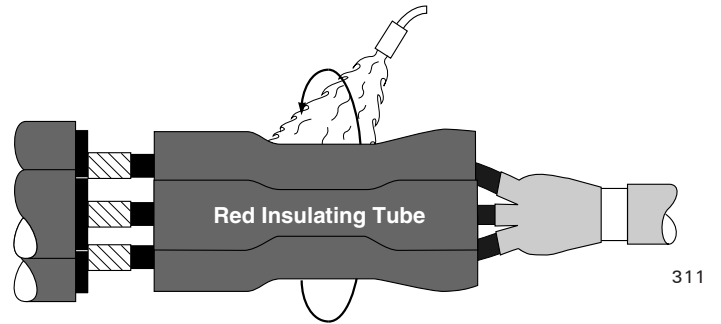

33. Apply red sealant

Remove backing from red sealant. Using light tension, wrap sealant over the cable, butted against the red insulating tube as shown. Build the sealant to the level of the red insulating tube.

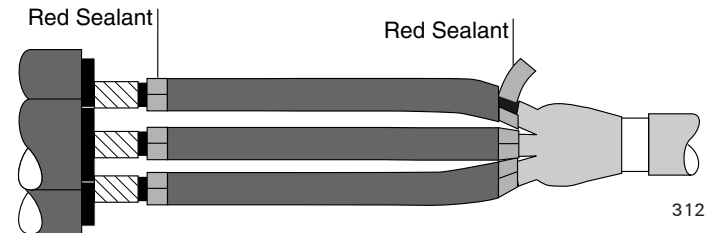

34. Position black/red dual layer tubes; shrink in place

Center tubes over the red insulating tubes. Shrink in place using the same method as in Step 31.

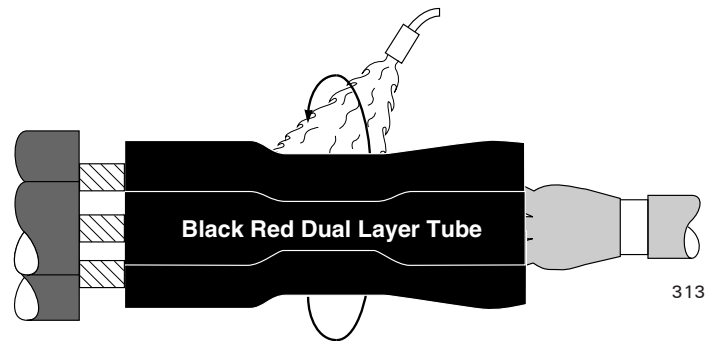

35. Position black reinforcing tubes; shrink in place

Center tubes over the black/red dual layer tubes. Shrink in place using the same method as in Step 31.

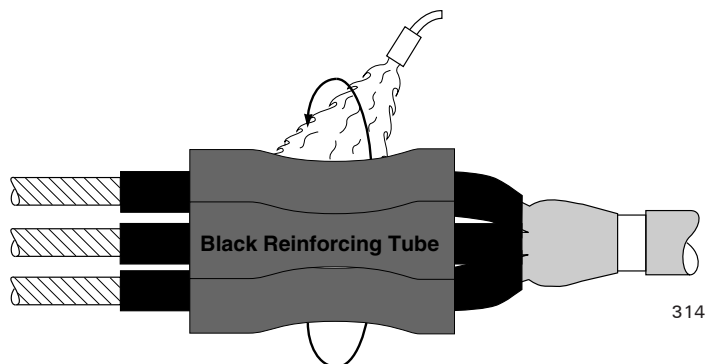

Note: If External Grounding or Shield Interrupting

Refer to the Raychem HVS-EG, "Guide for External Grounding and Shield Interrupting of Power Cable Splices" for modifications to these instructions.

36. Install ground

Choose the appropriate cable type (Choice 1-3) and follow the directions given to ground each phase.

Choice 1

If Drain Wire or UniShield Cable

Pigtail the shield wires and crimp on to the ground braid using the connectors provided.

Lay the braids across the splice tubes and solder ground braids to the lead sheath of the PILC cable. Deburr the connection, cut off excess braid and trim pigtailed wires.

Discard spring clamps, and foil tapes.

Go to Step 37.

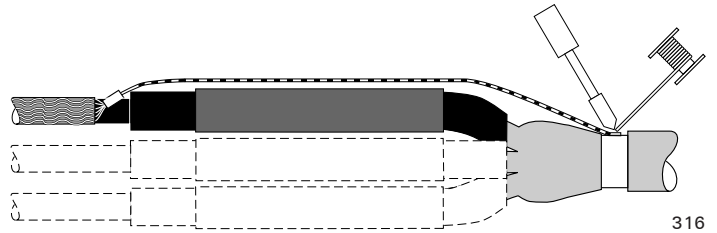
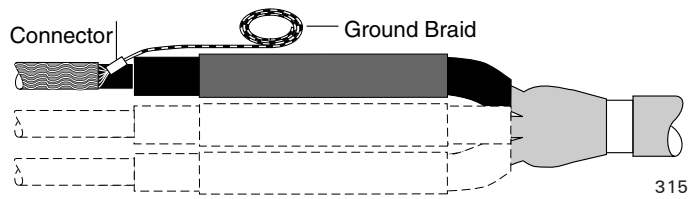

Choice 2

If Metallic Tape or LC Shield Cable

(1) Flare one end of the ground braid and place it onto the metallic tape, butted up to the red sealant.
 (2) Attach the braid to the shield by placing two wraps of the spring clamp over the braid. 3) Fold the braid back over the spring clamp wraps. Continue to wrap the remaining clamp over the braid.
 Tighten clamp by twisting it in the direction it is wrapped and secure with copper foil tape provided.

Lay the braids across the splice tubes and solder ground braids to the lead sheath of the PILC cable. Deburr the connection, cut off excess braid and trim pigtailed wires.

Discard drain wire connectors.

Go to Step 37.

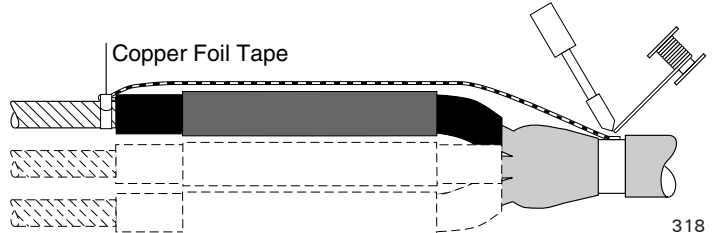
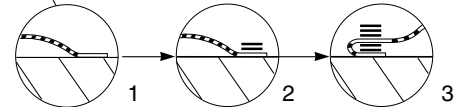
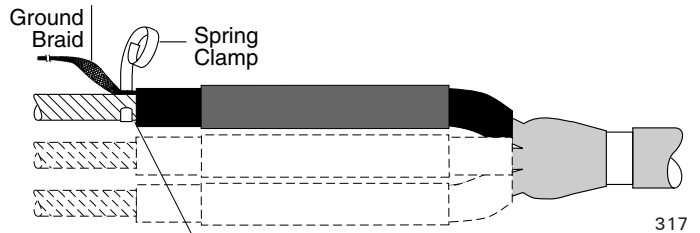

37. Connect grounding conductor(s)

Bend the grounding conductor(s) back over the tubes and solder to the lead sheath. (It may be necessary to splice in an extension to the ground conductor(s) in order to reach the lead sheath.)

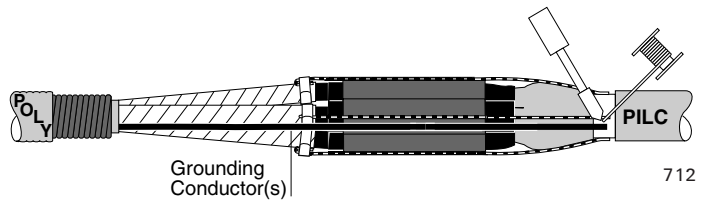

38. Install the shielding mesh

Starting on the cable shields, wrap a half-lapped layer of the mesh around all three phases across the length of the tubes and tie off on the lead sheath at the other side of the splice.

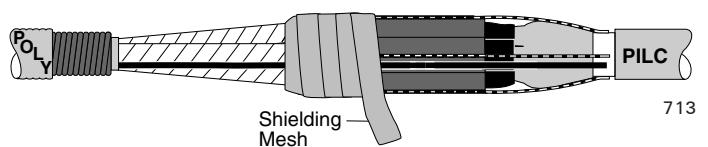

39. Install armorwrap

Position armorwrap around splice area and center on the exposed cable armor and lead sheath.

Bind the ends of the armorwrap to the cable armor and lead sheath with the tape provided.

Abrade and solvent clean cable jackets as shown to provide an oil-free, clean surface.

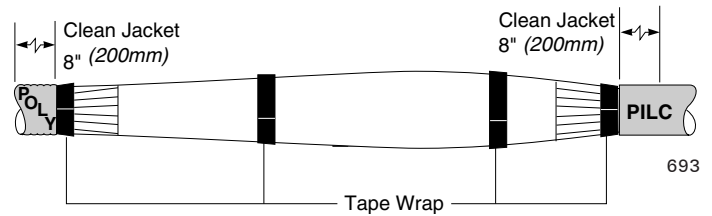

40. Apply sealant

Apply one wrap of black sealant starting at the jacket cutbacks around both cable jackets as shown.

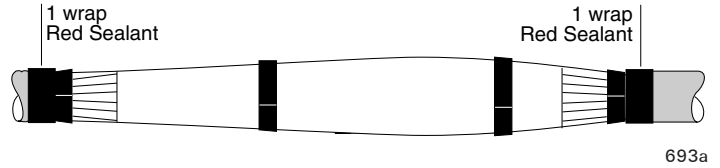

41. Position wraparound sleeve

Remove or tape over all sharp points to prevent puncture of wraparound sleeve. Remove backing from wraparound sealing sleeve and center sleeve over splice. Slide metal retention clip onto the butted rails.

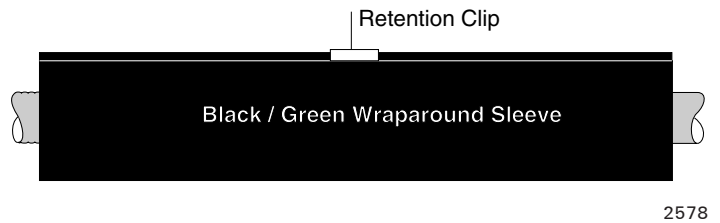

42. Install channel clip

Connect the channels by overlapping the retention clip as shown at right.

Note: Channels must overlap sleeve edge by 1/4 inch (5mm) minimum.

If channels slide on easily go to step 43. If channel fit seems tight, continue with next paragraph.

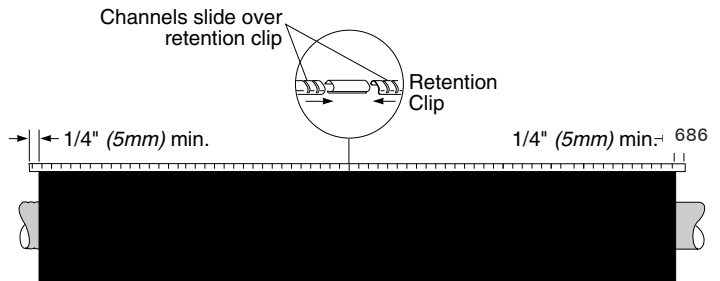

As shown in illustration A, make sure flap is not pinched between the rails. Push the sleeve up from the bottom and down from the top while sliding on channel as shown in illustration B. The idea is to flatten the rails together to prevent the channels from binding.

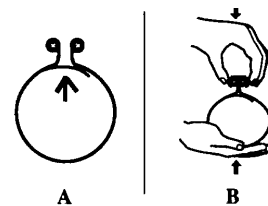

43. Shrink the wraparound sleeve

Preheat evenly along both sides of the rail/channel area until this area begins to shrink. To achieve uniform heating, move the flame back and forth from one side of the channel to the other as shown in illustration "A" while moving flame along the entire length of the channel as shown in illustration "B" until the sleeve starts to shrink. This technique will assure a properly preheated rail and channel area.

Begin shrinking at the center of the sleeve and work toward each end.

Apply heat until the sleeve is fully shrunk and the heat-sensitive green paint is completely converted to black. Continue heating the rail/channel area for another 5 seconds per foot. A white line should be visible in the channel gaps indicating sufficient heating.

Note: Green heat-sensitive paint will turn black as sleeve shrinks in place.

This completes the splice.

Note: Allow to cool before moving or placing in service.

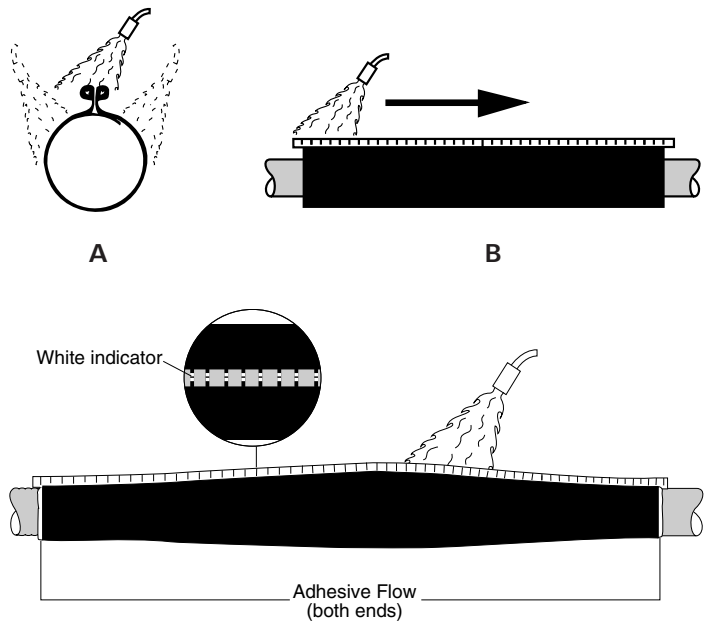

687

The Information contained in these installation instructions is for use only by installers trained to make electrical power installations and is intended to describe the correct method of installation for this product. However, Tyco Electronics Corporation has no control over the field conditions which influence product installation. It is the user's responsibility to determine the suitability of the installation method in the user's field conditions. Tyco Electronics' only obligations are those in Tyco Electronics' standard Conditions of Sale for this product and in no case will Tyco Electronics be liable for any other incidental, indirect or consequential damages arising from the use or misuse of the products.

TE (logo) and Tyco Electronics are trademarks. Copyright 1998, 2010 Tyco Electronics Corporation. All Rights Reserved.