

**PROPER USE GUIDELINES**

Cumulative Trauma Disorders can result from the prolonged use of manually powered hand tools. Hand tools are intended for occasional use and low volume applications. A wide selection of powered application equipment for extended-use, production operations is available.

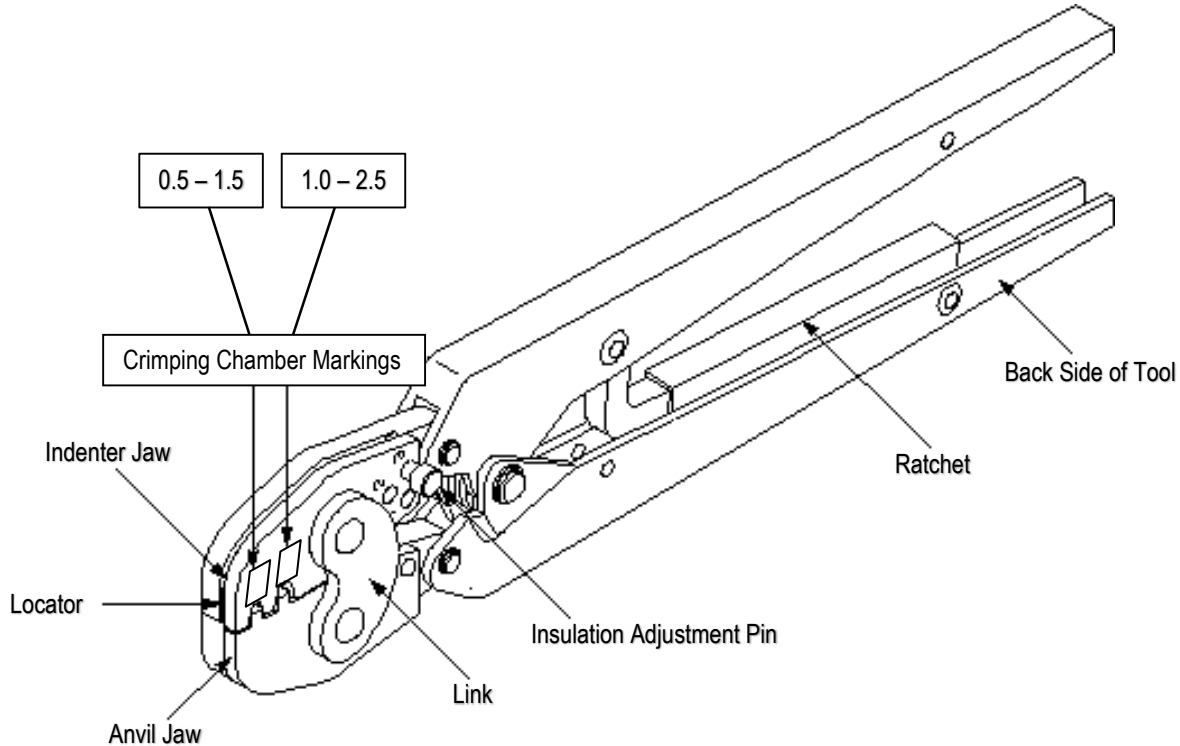

Tool		Terminal		Wire	
Part Number	Crimping Chamber Marking	Strip PN	Loose Piece PN	Range, mm <sup>2</sup>	Insulation Diameter Range, mm
675930-1	0.5-1.5	160430	160490	0.5-1.5	2.3-3.3
		160433	160493		
	1.0-2.5	160429	160491	1.0-2.5	3.1-3.8
		160431	160492		

Figure 1

**1. INTRODUCTION**

CERTI-CRIMP Hand Crimping Tool 675930-1 is designed to crimp FASTON\* .187 Series receptacles onto wire sizes 0.5-1.5 mm<sup>2</sup> and 1.0-2.5 mm<sup>2</sup>. Refer to Figure 1.

**i NOTE**  
 Read these instructions thoroughly before using the hand tool.

**i NOTE**  
 Dimensions in this instruction sheet are in metric units [with U.S. customary units in brackets]. Figures and illustrations are for reference only and are not drawn to scale.

Reasons for reissue of this instruction sheet are provided in Section 7, REVISION SUMMARY.

## 2. DESCRIPTION

Each hand tool features two jaws (anvil and indenter), a locator, an insulation adjustment pin, and a ratchet. When closed, the jaws form two crimping chambers each marked on the BACK side of the tool with the letters A and B. The wire size range is marked on the link. See Figure 1.

The locator positions the receptacle in the jaws and aids in locating the wire in the receptacle. The insulation adjustment pin is used to regulate the crimp height of the insulation barrel of the receptacle. The ratchet assures full crimping of the receptacle. Once engaged, the ratchet will not release until the tool handles have been FULLY closed.



### CAUTION

*The jaws bottom before the ratchet releases. This design feature ensures maximum electrical and tensile performance of the crimp. DO NOT re-adjust the ratchet.*

## 3. CRIMPING PROCEDURE

Select the appropriate receptacle and wire size for the hand tool. The wire size and insulation diameter must be within the specified range for the receptacle. Strip the wire to the length shown in Figure 2. DO NOT nick or cut the wire strands. Then, proceed as follows:

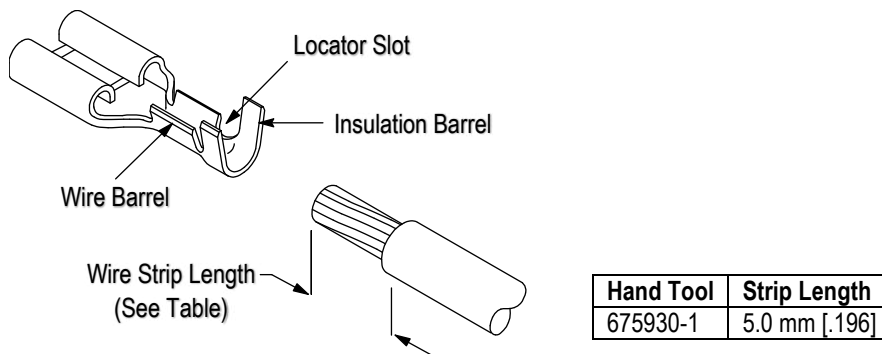

Figure 2

1. Hold tool so that the BACK side is facing you.
2. Open the jaws by squeezing the tool handles together until the ratchet releases.
3. Center the receptacle wire barrel in the appropriate nest of the anvil jaw (refer to Figure 1). Make sure the tool locator enters the receptacle locator slot. See Figure 3.

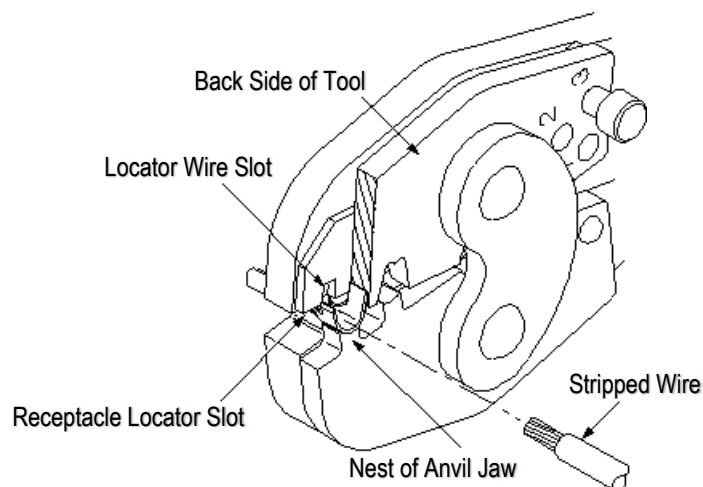

Figure 3

4. Holding the receptacle in place, squeeze the tool handles together just enough to hold the receptacle in the jaws.

**CAUTION**

*Squeezing the handles together excessively will deform the wire barrel.*

5. Insert the stripped wire into the receptacle insulation barrel and through the wire slot of the tool locator until the wire insulation butts against the locator. See Figure 3.
6. Holding the wire in place, squeeze the tool handles together until the ratchet releases.
7. Allow the tool handles to open FULLY and remove the crimped receptacle from the tool.

#### 4. INSULATION CRIMP ADJUSTMENT

Each tool has three insulation adjustment positions to adjust the wire insulation grip: 1-Small, 2-Medium, and 3-Large. To determine the proper insulation crimp setting, proceed as follows:

1. Insert the adjustment pin into Position 3 as shown in Figure 1.
2. Position the receptacle into the jaws as described in Section 3, CRIMPING PROCEDURE.
3. Insert an UNSTRIPPED wire into just the insulation barrel of the receptacle. Crimp the receptacle and remove it from the jaws.
4. Check the insulation support by bending the wire back and forth once. The insulation barrel should retain grip on the wire insulation. If the wire pulls out, move the insulation adjustment pin to the next smaller position (2) and perform another test crimp. If the wire does not pull out, the pins are properly adjusted.

Move the insulation adjustment pin as necessary until the desired insulation grip is obtained. The crimp should hold the wire insulation firmly without cutting into it.

#### 5. MAINTENANCE AND INSPECTION PROCEDURE

It is recommended that a maintenance and inspection program be performed periodically to ensure dependable and uniform terminations. Though recommendations call for at least one inspection a month, frequency of inspection depends on:

- ◆ The care, amount of use, and handling of the hand tool,
- ◆ The presence of abnormal amounts of dust and dirt,
- ◆ The degree of operator skill, and,
- ◆ The established standards of the facility.

The hand tool is inspected before being shipped; however, it is recommended that the tool be inspected immediately upon arrival to ensure that the tool has not been damaged during shipment.

##### 5.1. Daily Maintenance

1. Hand tool should be immersed (handles partially closed) in a reliable commercial degreasing compound to remove accumulated dirt, grease, and foreign matter. When degreasing compound is not available, tool may be wiped clean with a soft, lint-free cloth. DO NOT use hard or abrasive objects that could damage the tool.
2. Make certain that the retaining pins are in place and that they are secured with retaining rings.
3. All pins, pivot points, and bearing surfaces should be protected with a THIN coat of any good SAE 20 motor oil. DO NOT oil excessively.
4. When the tool is not in use, keep handles closed to prevent objects from becoming lodged in the jaws. Store the tool in a clean, dry area.

## 5.2. Periodic Inspection

### A. Lubrication

Lubricate all pins, pivot points, and bearing surfaces with SAE 20 motor oil as follows:

- ◆ Tool used in daily production - lubricate daily
- ◆ Tool used daily (occasional) - lubricate weekly
- ◆ Tool used weekly - lubricate monthly

Wipe excess oil from tool, particularly from crimping area. Oil transferred from the crimping area onto certain terminations may affect the electrical characteristics of an application.

### B. Visual Inspection

1. Close the tool handles until the ratchet releases and then allow them to open freely. If they do not open quickly and fully, the spring is defective and must be replaced. See Section 6, REPLACEMENT AND REPAIR.
2. Inspect the jaws for worn, cracked, or broken areas. If damage is evident, return the tool for evaluation and repair. See Section 6, REPLACEMENT AND REPAIR.

### C. Crimp Height Inspection

Crimp height inspection is performed through the use of a micrometer with a modified anvil, commonly referred to as a crimp-height comparator. TE does not manufacture or market crimp-height comparators. Detailed information on obtaining and using crimp height comparators can be found in Instruction Sheet 408-7424.

Proceed as follows:

1. Select a receptacle and maximum size wire for each crimping chamber.
2. Refer to Section 3, CRIMPING PROCEDURE, and crimp the receptacle accordingly.
3. Measure the wire barrel crimp height as shown in Figure 4. If the crimp height conforms to that height, the tool is considered dimensionally correct. If not, return the tool for evaluation and repair. See Section 6, REPLACEMENT AND REPAIR.

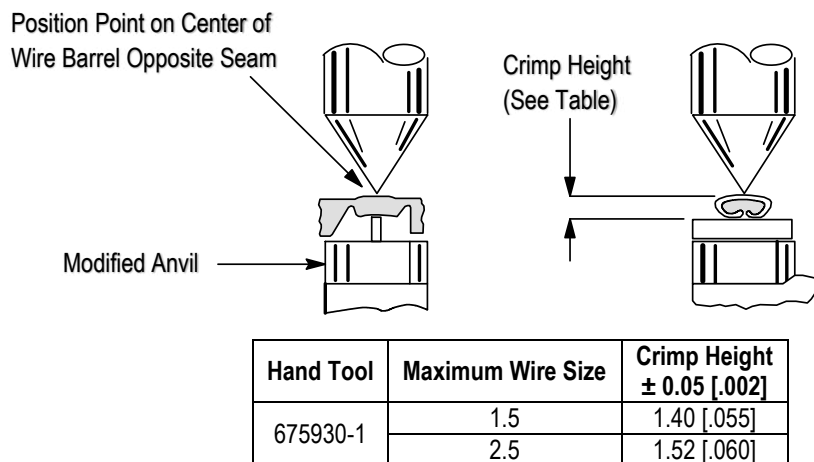

Figure 4

### D. Ratchet Inspection

1. Select a receptacle and maximum size wire for the tool.
2. Position the receptacle and wire between the jaws as described in Section 3, CRIMPING PROCEDURE.

3. Hold the wire in place and squeeze the handles until the ratchet releases. Hold the handles in this position, maintaining just enough tension to keep the jaws closed.
4. Check the clearance between the bottoming surfaces of the jaws. If the clearance is 0.025 mm [.001 in.] or less, the ratchet is satisfactory. If clearance exceeds 0.025 mm [.001 in.], the ratchet is out of adjustment and must be repaired. See Section 6, REPLACEMENT AND REPAIR.

## 6. REPLACEMENT AND REPAIR

Customer-replaceable parts are listed in Figure 5. A complete inventory can be stocked and controlled to prevent lost time when replacement of parts is necessary. Order replacement parts through your TE Representative, or call 1-800-526-5142, or send a facsimile of your purchase order to 717-986-7605, or write to:

CUSTOMER SERVICE (038-035)  
 TE CONNECTIVITY CORPORATION  
 PO BOX 3608  
 HARRISBURG PA 17105-3608

For tool evaluation and customer repair service, call 1-800-526-5136.

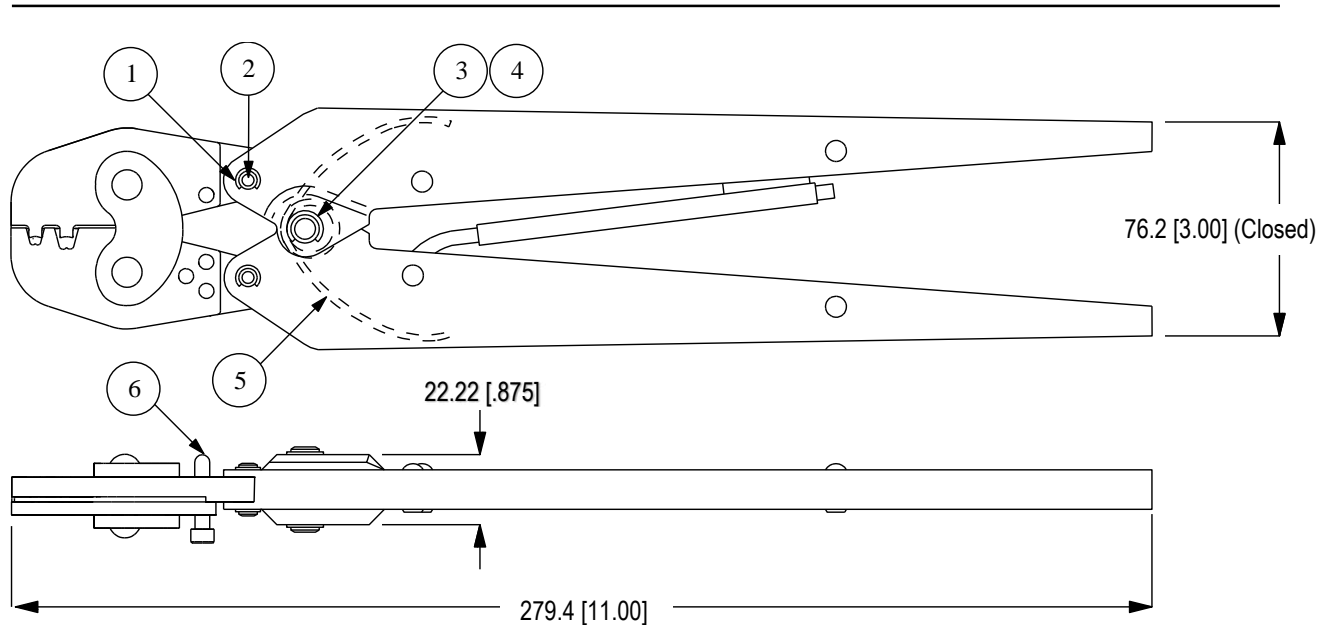

**Weight:** 539 g [1 lb 3 oz]

REPLACEMENT PARTS			
Item	Part Number	Description	Qty Per Tool
1	21045-3	RING, External Crescent Retaining, .188-in. D Shaft	4
2	8-59558-2	PIN, Retaining, .187-in. D x .521 in. L	2
3	21045-6	RING, External Crescent Retaining, .250-in. D Shaft	2
4	2-23620-9	PIN, Retaining, .250-in. C x .838 in. L	1
5	39364	SPRING, Handle	1
6	39207	ADJUSTMENT PIN, Insulation Crimp	1

Figure 5

## 7. REVISION SUMMARY

Initial Release