

NOTE: Not to Scale

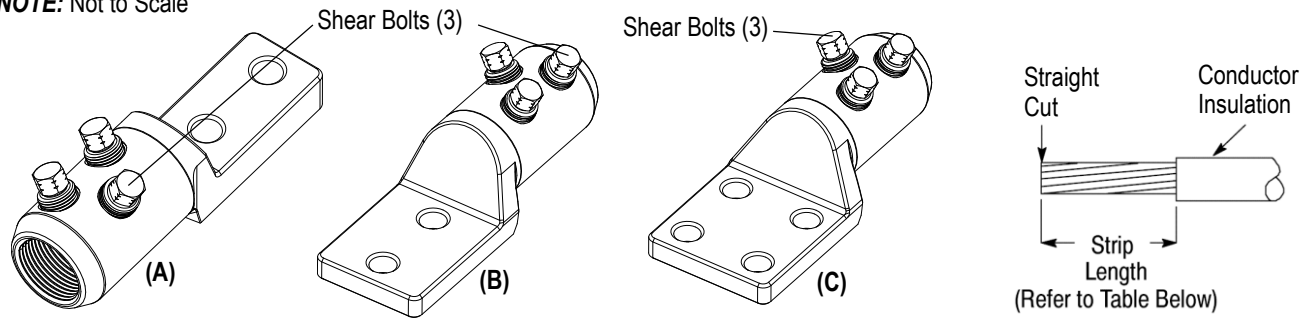

CONNECTOR						CABLE		
FIGURE LETTER (REF)	PART NO. AND CATALOG NO.	LENGTH (mm [in.])	OD (mm [in.])	SOCKET SIZE (mm [in.])	PAD WIDTH	CONDUCTOR RANGE	STRIP LENGTH (mm [in.])	CONDUCTOR DIA RANGE (mm [in.])
A	1974132-1 ASBT-1250-2-N (3-Bolt)	176.7 [6.96]	50.8 [2]	13 [1/2]	42 [1.7]	1250 kcmil Compact Stranded to 1250 kcmil Compressed Stranded	75 [2.95]	30.23-31.75 [1.19-1.25]
B	1974133-1 ASBT-1250-2 (3-Bolt)	176.7 [6.96]	50.8 [2]	13 [1/2]	63.5 [2.5]	1250 kcmil Compact Stranded to 1250 kcmil Compressed Stranded	75 [2.95]	30.23-31.75 [1.19-1.25]
C	1974134-1 ASBT-1250-4 (3-Bolt)	176.7 [6.96]	50.8 [2]	13 [1/2]	76 [3]	1250 kcmil Compact Stranded to 1250 kcmil Compressed Stranded	75 [2.95]	30.23-31.75 [1.19-1.25]

Figure 1

1. INTRODUCTION

This instruction sheet provides installation procedures for the Aluminum ShearBolt Terminals that accommodates 1250 kcmil aluminum or copper conductors.

To obtain information on Energy Products, visit the TE Connectivity Energy website at: <http://energy.te.com>.



NOTE

Dimensions in these instructions are in metric units [with imperial units in brackets]. Figures are for reference only and are not drawn to scale.

Reasons for re-issue can be found in Section 3, REVISION SUMMARY.

ShearBolt Terminals are designed to be compatible with Raychem cable accessories and insulation products. For other applications, consult the manufacturer's installation instructions for compatibility.

2. INSTALLATION PROCEDURES

2.1. Cable Preparation



CAUTION

DO NOT use a conductor that has been previously terminated.

1. Ensure that the 1250 kcmil conductor end has a straight (right-angle) cut. Strip conductor end to the dimension shown in the table in Figure 1.
2. Using a wire brush dedicated for use on aluminum or copper conductors, thoroughly clean the bare surface strands of each conductor end. Cleaned conductor ends should be installed immediately to prevent reformation of fresh oxides.

2.2. Connector Installation

1. Back out all bolts to give clearance for the conductor in the connector body. DO NOT remove the inhibitor contained inside the connector.



NOTE

Do not completely remove bolts from the connector body. Removing bolts followed by improper bolt re-installation could result in stripping of the threads.

2. Insert the conductor into the connector body. For proper installation, there should be NO GAP between the insulation and the connector body.
3. Tighten bolts in a three-step process:
 - a. Hand-tighten the bolts to firmly grip conductors in place. Follow the tightening sequence shown in Figure 2.
 - b. Using a wrench with a hexagonal socket, tighten the bolts one to one-and-a-half turns, (one second interval if using the TE Connectivity [cordless] impact wrench), repeating the sequence in the previous step. Bolts should remain un-sheared. Prevent core bending by using Holding Tool 188072-000 (or equivalent) with the wrench as shown in Figure 2.



NOTE

Cordless Impact Wrench CA 7469-000 can be used instead for installation. A holding tool is not needed if using this wrench.

- c. Repeat the sequence (above), tightening each bolt until the head of the bolt shears off. The wrench should remain parallel to the connector body.
4. Smooth sharp edges of protruding bolts using the sandpaper provided. Clean connector to remove particles.
5. For medium voltage applications, all bolt heads must be covered with the termination body to prevent moisture ingress. For PILC applications, additional oil sealing components must be specified.

3. REVISION SUMMARY

- Initial release of document

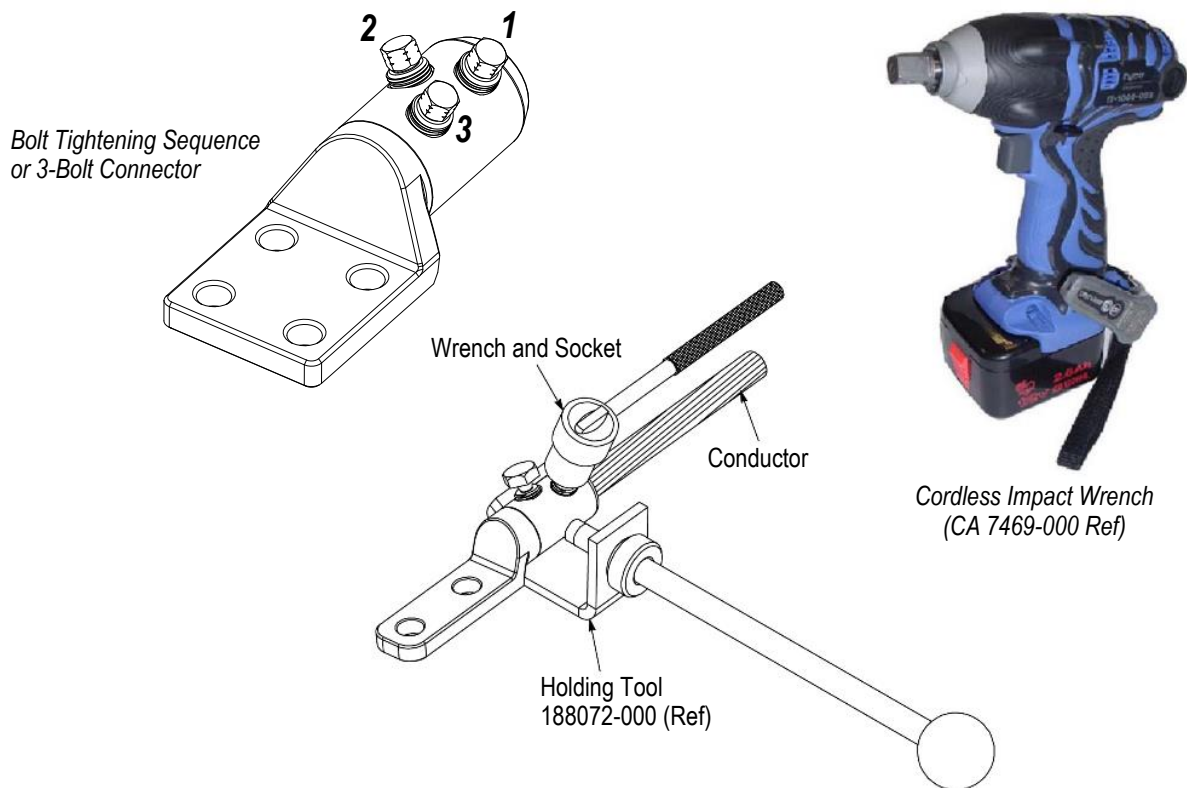

Figure 2