

Figure 1

1. INTRODUCTION

SMPM Jack (Direct Solder Attachment) Connector 1757642-1 shown in Figure 1 is designed to be soldered to semi-rigid coaxial cable with a diameter of 1.20 mm [.047 in.] using the tools referenced in Figure 2.

TOOL DESCRIPTION	TOOL PART NUMBER	
	CURRENT	PREVIOUS
Cable Fixture Subassembly	1055439-1	2098-5206-54 (T-4567)
Insert Assembly	1055543-1	2098-5797-54
Locator Tool (For Housing Subassembly)	1055887-1	2598-5406-02

Figure 2

NOTE Dimensions in this instruction sheet are in millimeters [with inches in brackets]. Figures and illustrations are for reference only and are not drawn to scale.

2. DESCRIPTION

The jack consists of a one-piece connector assembly. See Figure 1.

3. ASSEMBLY PROCEDURE

DANGER Follow safety precautions included with the tools used for assembly.

1. Insert the squared cable end into Hole Pattern 2 of the cable fixture subassembly. Refer to Figure 3.

2. Place a saw in the saw slot and while rotating the cable, cut through the cable jacket and into, but not through, the dielectric. Remove the cable from the cable fixture subassembly, and finish cutting the dielectric with a blade.

3. Pry the jacket and dielectric from the cable to expose the center conductor. Make sure that the center conductor meets the dimension shown in Figure 3.

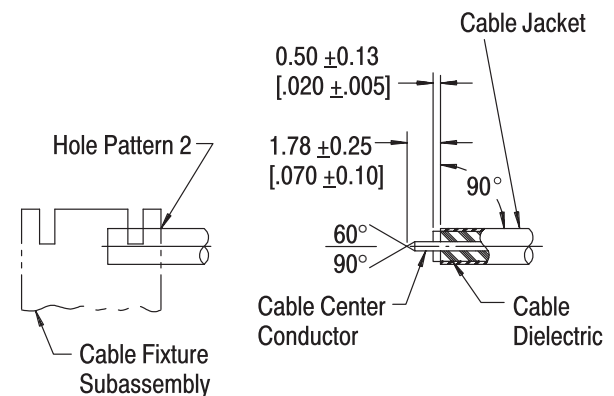

Note: Not to Scale

Figure 3

4. Insert the cable into the housing subassembly until it bottoms.

5. Place the assembly in the cable fixture subassembly as shown in Figure 4. Tighten the clamp screw to secure the cable, and tighten the locator tool to seat the housing subassembly firmly against the cable.

6. Using solder made of 60% tin and 40% lead, join the housing subassembly to the cable at the location shown in Figure 4.

7. Adherence to assembly procedure should yield tolerances shown in Figure 5.

4. REPLACEMENT AND REPAIR

CAUTION Components of the jack are not repairable. Replace any defective or damaged components.

5. REVISION SUMMARY

- Initial release of document

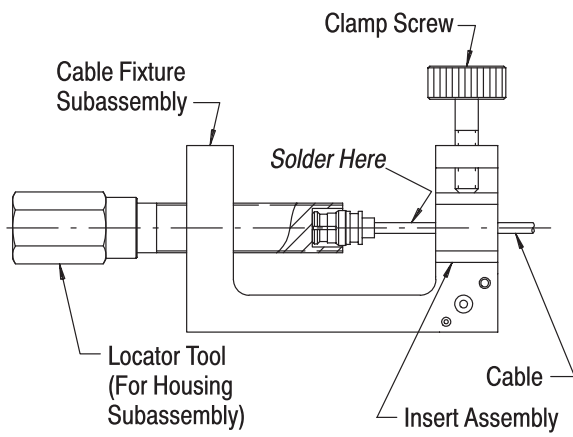

Figure 4

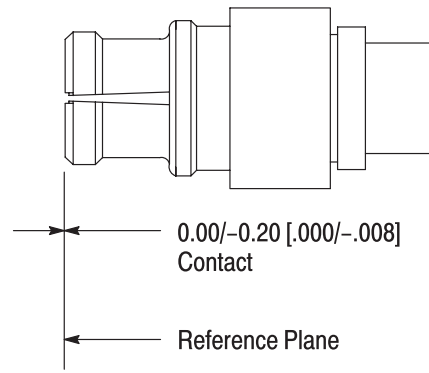

Figure 5