46 WAY ABS / EPB CONNECTOR

TABLE OF CONTENTS**1 GENERAL**

- 1.1 PURPOSE
- 1.2 CUSTOMER DRAWINGS / INTERFACE SPECIFICATION
- 1.3 DELIVERY CONDITION OF CONNECTOR AND WIRE COVERS
- 1.4 APPLICABLE COMPONENTS

2 CONNECTOR OPERATING INSTRUCTIONS

- 2.1 ASSEMBLY OF THE CONNECTOR
- 2.2 TERMINAL INSERTION / REMOVAL INSTRUCTIONS
 - 2.2.1 TERMINAL INSERTION
 - 2.2.2 SPACER (TPA) REMOVAL
 - 2.2.3 TERMINAL EXTRACTION
- 2.3 WIRE OUTER DIAMETER REQUIREMENTS FOR SEALING (MAT SEAL)
- 2.4 COVER MOUNTING / REMOVAL INSTRUCTIONS FOR CABLE EXIT 180°/90°
 - 2.4.1 COVER MOUNTING
 - 2.4.2 COVER REMOVAL

3 CONNECTOR MATING / UNMATING ON / FROM AGGREGATE HEADER

- 3.1 CONNECTOR MATING
- 3.2 CONNECTOR UNMATING

1 GENERAL

1.1 PURPOSE

THIS SPECIFICATION DESCRIBES HOW TO HANDLE THE 46 WAY CONNECTOR COMPONENTS.

1.2 CUSTOMER DRAWINGS / INTERFACE SPECIFICATION

THIS APPLICATION SPECIFICATION IS BASED ON THE LATEST VALID CUSTOMER DRAWINGS.

C2141968 46 WAY ABS CONNECTOR ASSEMBLY

C2141969 46 WAY ABS CONNECTOR WIRE COVER ASSEMBLY,
CABLE EXIT 180°

C2141685 46 WAY ABS CONNECTOR WIRE COVER ASSEMBLY, CABLE EXIT 90°

INTERFACE SPECIFICATION: 114-94025 46 WAY ABS CONNECTOR

1.3 DELIVERY CONDITION OF CONNECTOR AND WIRE COVERS

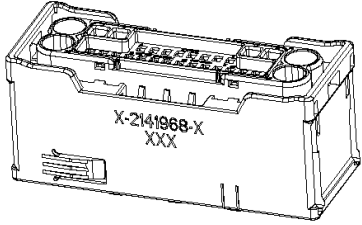
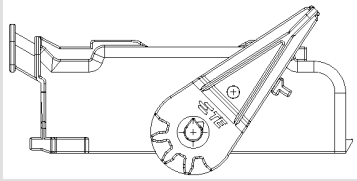
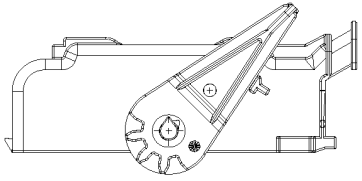
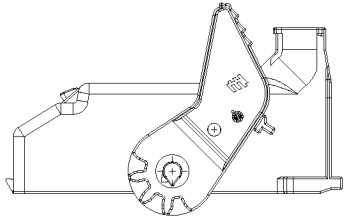
| | | |
|--|-----------------------|---|
| <p>46 WAY ABS CONNECTOR ASSEMBLY</p> | <p>PN X-2141968-X</p> |  |
| <p>46 WAY ABS CONNECTOR WIRE COVER ASSEMBLY, CABLE EXIT 180° LEFT</p> | <p>PN 0-2141969-1</p> |  |
| <p>46 WAY ABS CONNECTOR WIRE COVER ASSEMBLY, CABLE EXIT 180° RIGHT</p> | <p>PN 0-2141969-2</p> |  |
| <p>46 WAY ABS CONNECTOR WIRE COVER ASSEMBLY, CABLE EXIT 90° RIGHT</p> | <p>PN 0-2141685-1</p> |  |

 NOT TOOLED

1.4 APPLICABLE COMPONENTS

| APPLICABLE COMPONENTS BOX | | | | | |
|--|-----------------|----------|---|--------------------------------|----------------------------|
| DESCRIPTION | PLATING /COLOUR | SUPPLIER | SUPPLIER PART NO. (WIRE SIZE)  | TE APPL. SPEC. /TE PROD. SPEC. | APPL CONTACT CAVITY NUMBER |
| 0.64 GENERATION Y UNSEALED FEMALE TERMINAL | TIN | TE | 2098753-6 | 114-13183 | 4-11, 15-29, 31-45 |
| 0.64 GENERATION Y UNSEALED FEMALE TERMINAL | TIN | TE | 2098753-5 | 114-13183 | 4-11, 15-29, 31-45 |
| 2.8 UNSEALED FEMALE TERMINAL | TIN | FCI | 54002231 (AWG 22) | - | 2, 3, 12, 13 |
| 2.8 UNSEALED FEMALE TERMINAL | TIN | FCI | 54001431 (AWG 14) | - | 2, 3, 12, 13 |
| 2.8 UNSEALED FEMALE TERMINAL | TIN | FCI | 54001839 (AWG 18) | - | 2, 3, 12, 13 |
| 6.3 SEALED FEMALE TERMINAL | TIN | YAZAKI | 7116-4140-02 (0.5-1.0mm ²) | - | 1, 14, 30, 46 |
| 6.3 SEALED FEMALE TERMINAL | TIN | YAZAKI | 7116-4141-02 (1.5mm ²) | - | 1, 14, 30, 46 |
| 6.3 SEALED FEMALE TERMINAL | TIN | YAZAKI | 7116-4142-02 (2.5-4.0mm ²) | - | 1, 14, 30, 46 |
| 6.3 SEALED FEMALE TERMINAL | TIN | YAZAKI | 7116-4143-02 (AWG 10) | - | 1, 14, 30, 46 |
| WIRE SEAL FOR 6.3 TERMINAL (SMALL) | RED | YAZAKI | 7158-3081-50 | - | - |
| WIRE SEAL FOR 6.3 TERMINAL (MEDIUM) | BLUE | YAZAKI | 7158-3082-90 | - | - |
| WIRE SEAL FOR 6.3 TERMINAL (LARGE) | BLACK | YAZAKI | 7158-3083 | - | - |
| WIRE SEAL FOR 6.3 TERMINAL (X-LARGE) | LIGHT GREY | YAZAKI | X39858-A400 | - | - |
| PLUG FOR 6.3 TERMINAL | GREEN | YAZAKI | 7158-3080-60 | - | 1, 14, 30, 46 |



ONLY FOR INFORMATION. CHECK LATEST REVISION OF THE SUPPLIER SPECIFICATION FOR TERMINAL PROPERTIES

2 CONNECTOR OPERATING INSTRUCTIONS

2.1 ASSEMBLY OF THE CONNECTOR

- 1 FEMALE HOUSING
- 2 SLIDER RIGHT
- 3 SLIDER LEFT
- 4 SPACER (TPA)
- 5 PERIPHERAL SEAL
- 6 MAT SEAL
- 7 MAT SEAL COVER

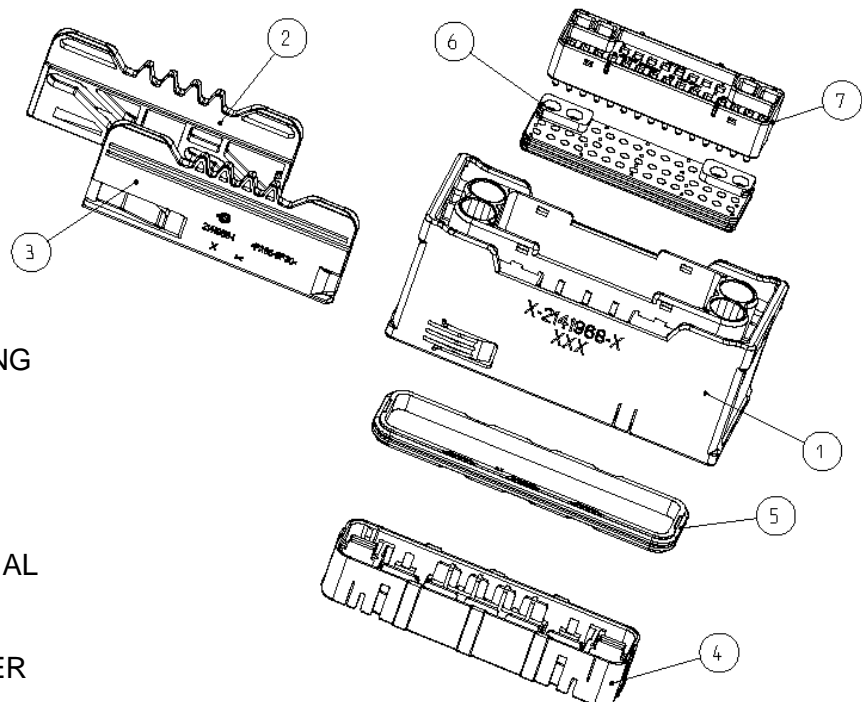

2.2 TERMINAL INSERTION / REMOVAL INSTRUCTIONS

2.2.1 TERMINAL INSERTION

GENERATION Y (0.64)

INSERT TERMINALS STRAIGHT IN CAVITIES UNTIL "CLICK".

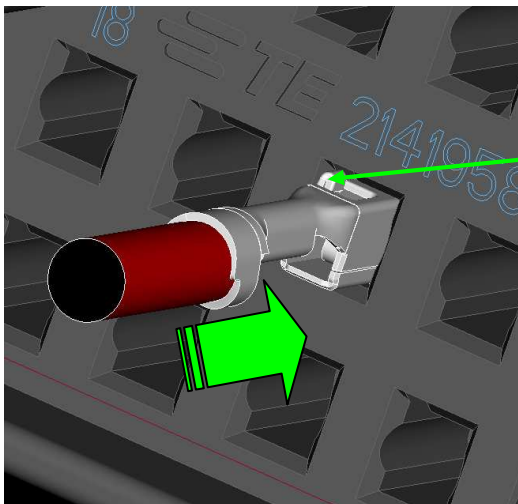

TERMINAL ORIENTATION
FEATURE

FCI APEX 2.8

INSERT TERMINALS STRAIGHT IN CAVITIES UNTIL "CLICK".

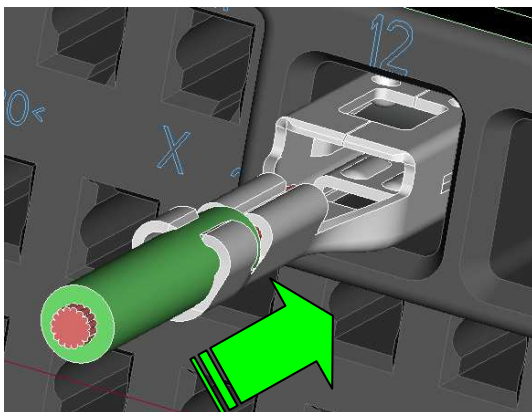

NO TERMINAL
ORIENTATION FEATURE

YAZAKI 6.3

INSERT TERMINALS STRAIGHT IN CAVITIES UNTIL "CLICK".

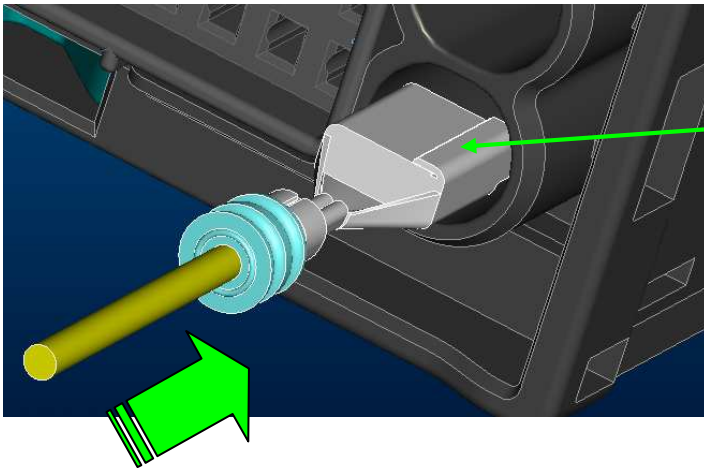

TERMINAL ORIENTATION
FEATURE

NOTE:

AFTER TERMINAL INSERTION OPERATION THE SPACER (TPA) MUST BE MOVED FROM PRE-LOCK POSITION TO FULLY ENGAGED POSITION.

2.2.2 SPACER (TPA) REMOVAL

SPACER (TPA) IN FULLY ENGAGED POSITION.

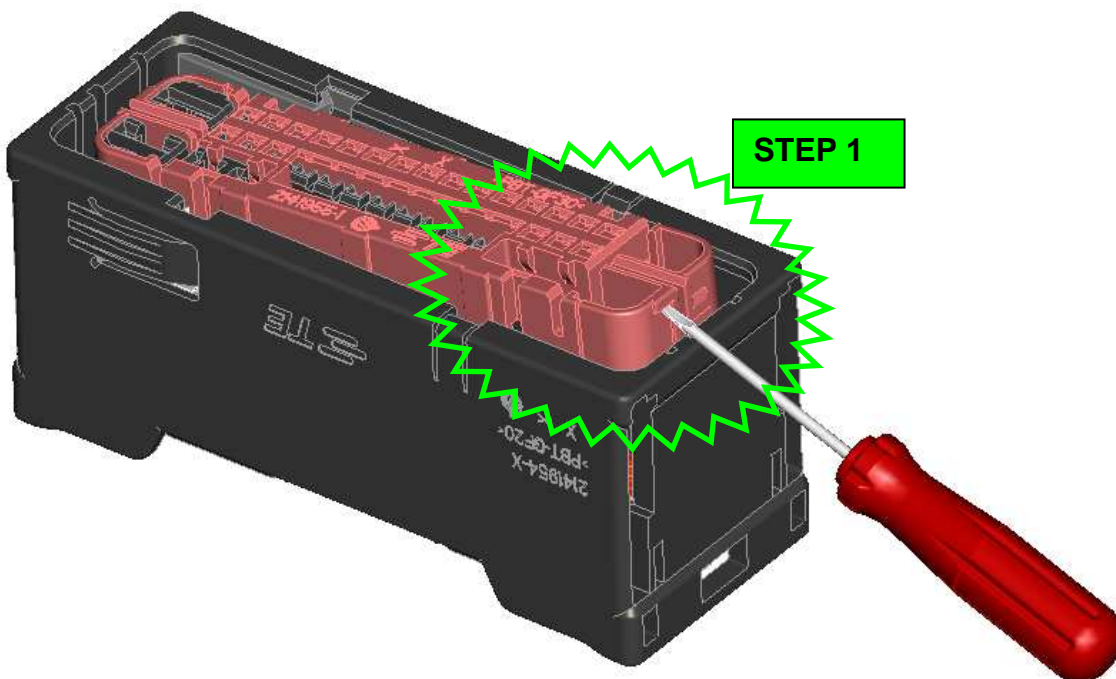

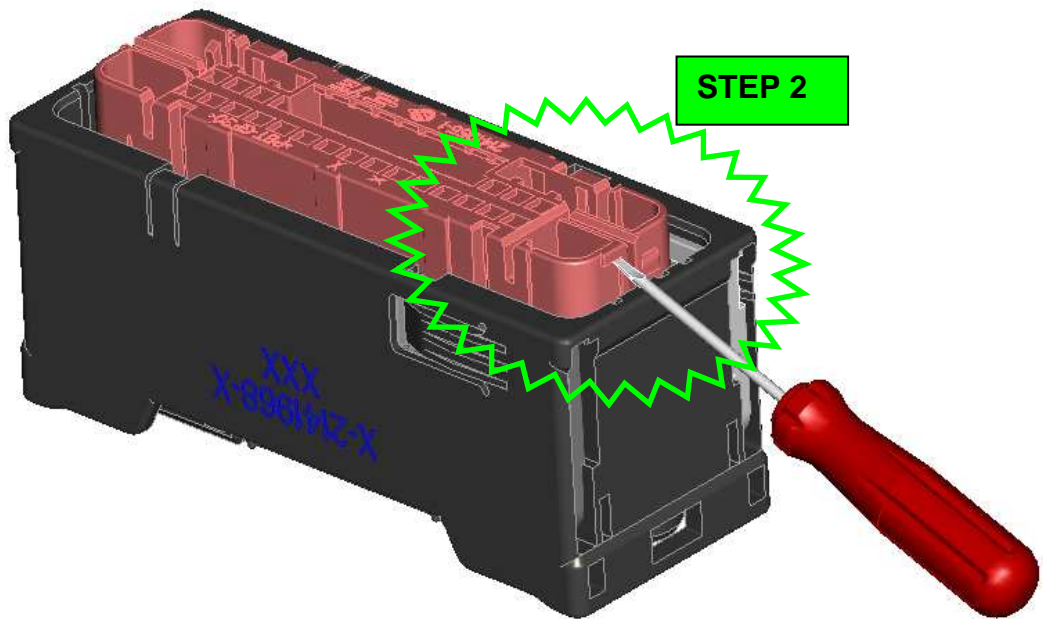
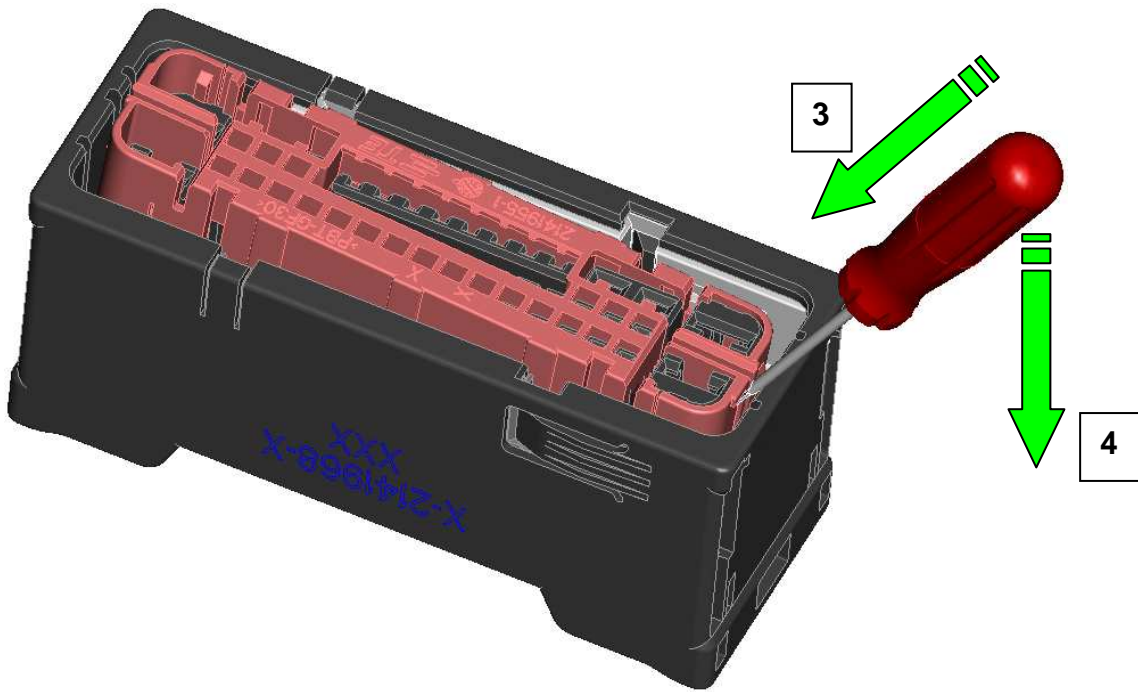

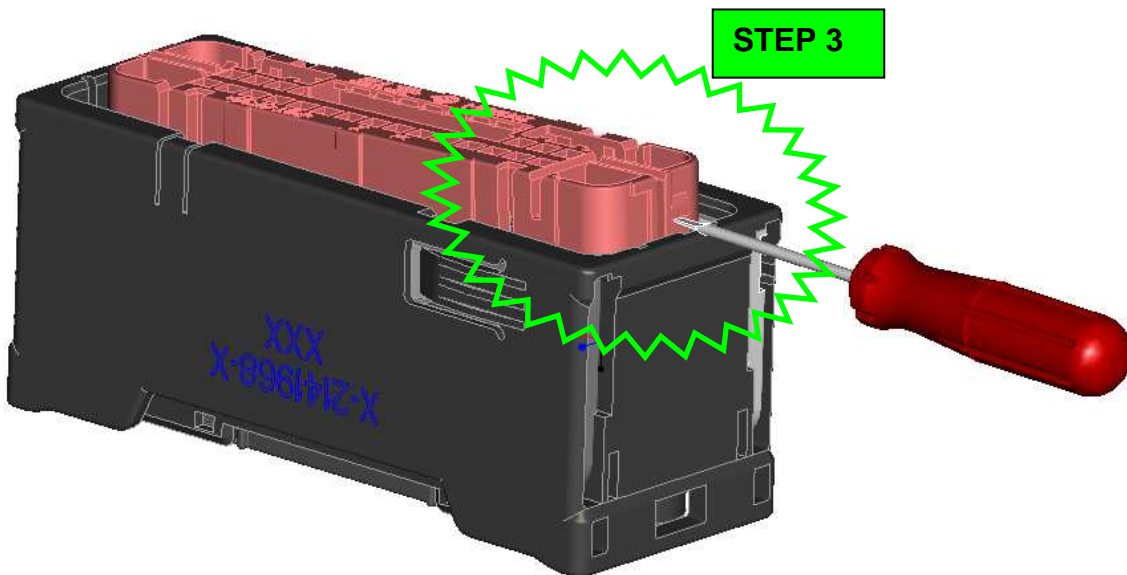
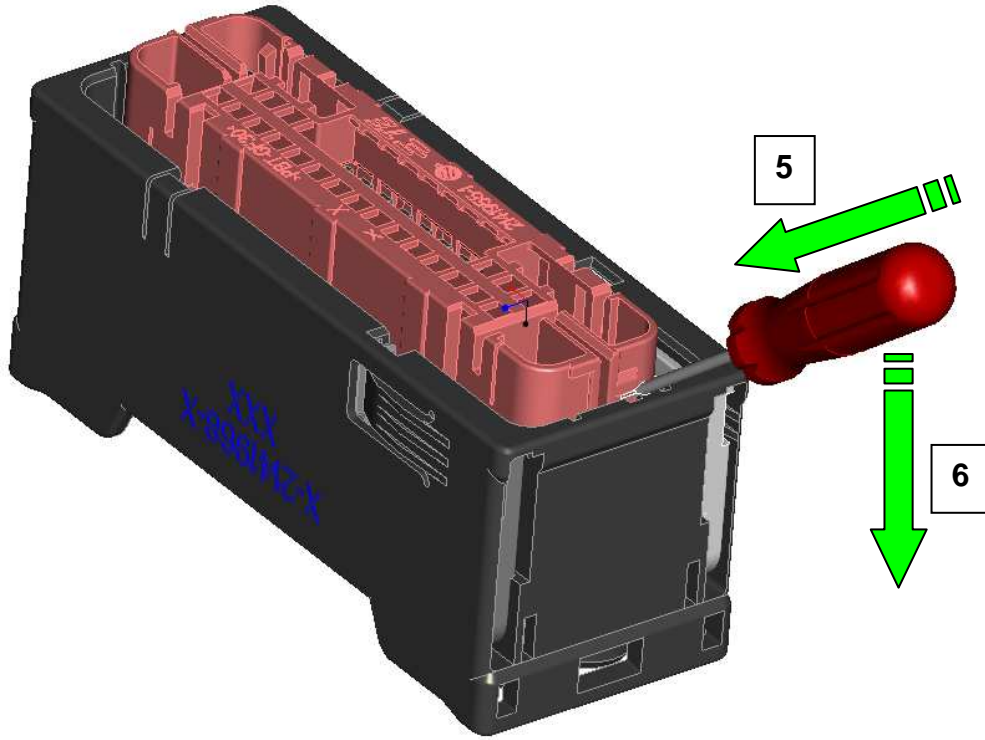

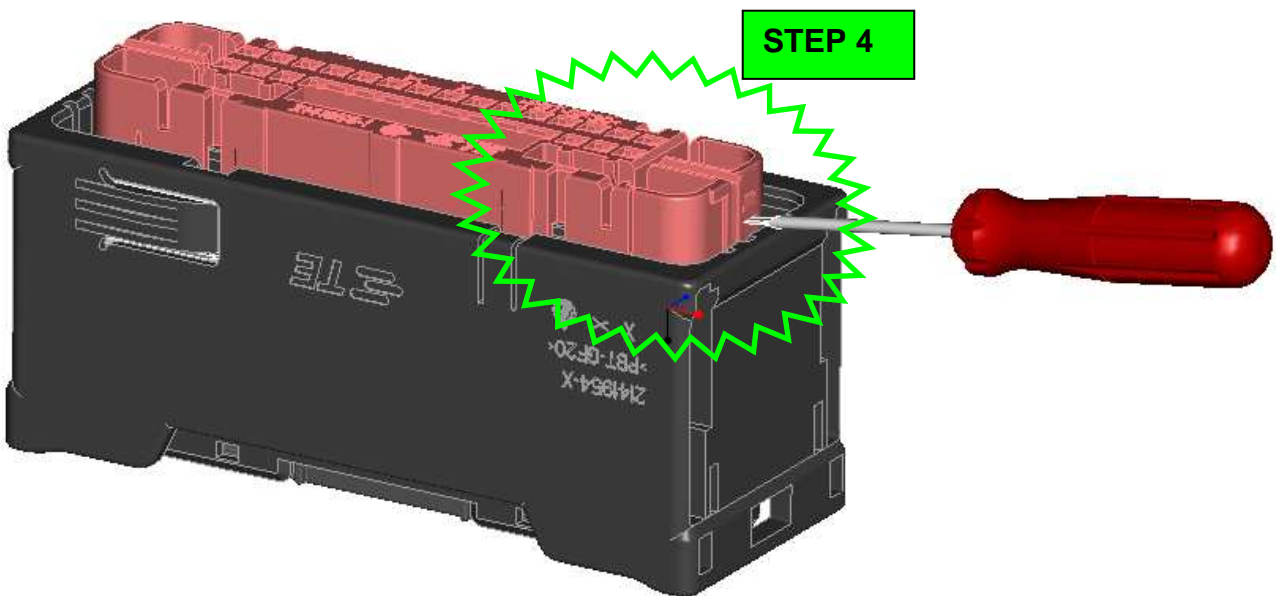
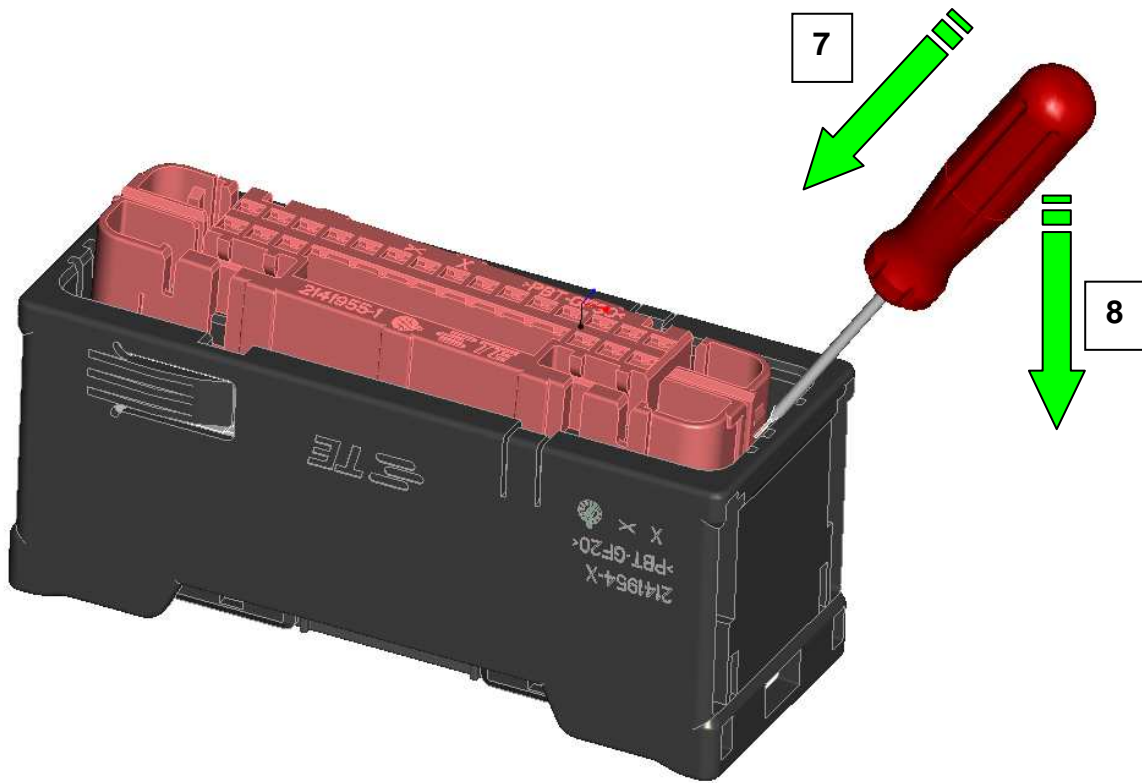

NOTE: TPA (SPACER) CAN NOW BE TAKEN AWAY FROM THE HOUSING

2.2.3 TERMINAL EXTRACTION –APPLY TO ALL TERMINALS**NOTE:**

TPA (SPACER) MUST BE FULLY REMOVED BEFORE TERMINAL REMOVAL OPERATIONS!

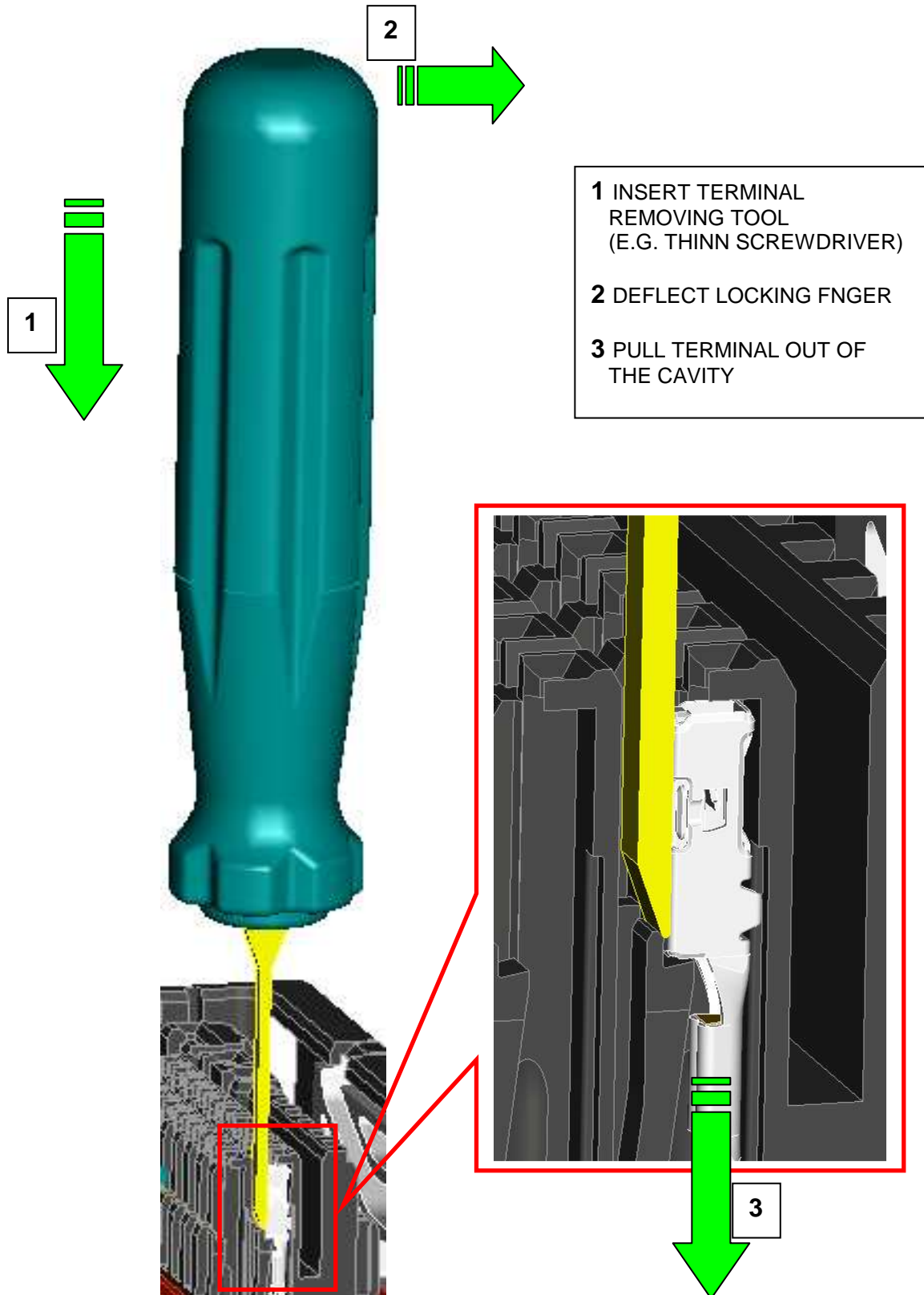

Attention for Generation Y terminal removal:

- 2 rows (contact cavities 4-11; 15-29) - standard cavities with overstress wall
- 1 row (contact cavities 31-45): no overstress wall. Locking finger deflection limited to max 0.6mm. Take care during terminal removal operation.

Locking finger may break if overdeflected

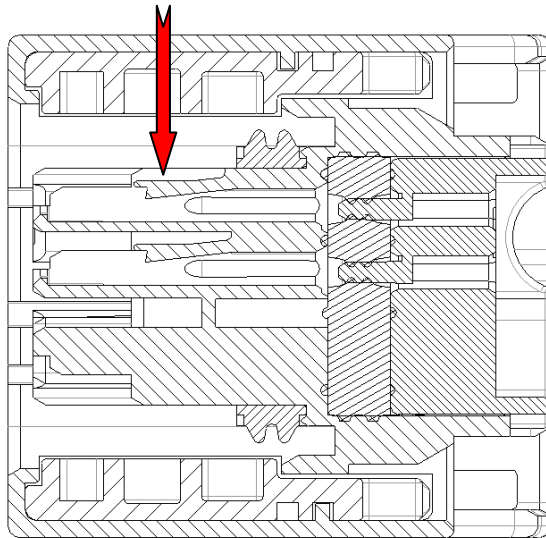

TE recommendation: Use a deflection-stop tool as shown below. APPENDIX A shows the dimensions of the tool



PLACE THE DEFLECTION-STOP TOOL ON THE HOUSING WALL BESIDE OF THE CONTACT CAVITIES 31-45 AS SHOWN AND PERFORM THE TERMINAL EXTRACTION OPERATION AS DESCRIBED ABOVE

2.3 WIRE OUTER DIAMETER REQUIREMENTS FOR SEALING (MAT SEAL)

PLEASE SEE CUSTOMER DRAWING

2.4 COVER MOUNTING / REMOVAL INSTRUCTIONS FOR CABLE EXIT 180°/90°

2.4.1 COVER MOUNTING

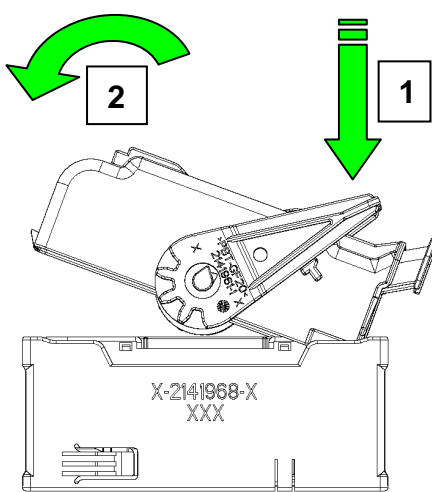

0-2141969-2 (180°)

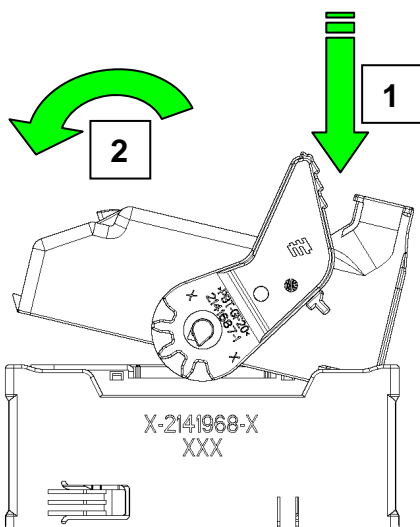
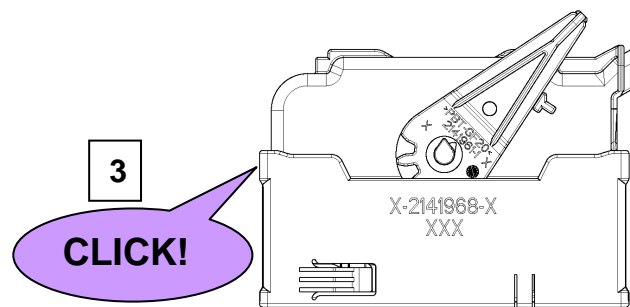

0-2141685-1 (90°)

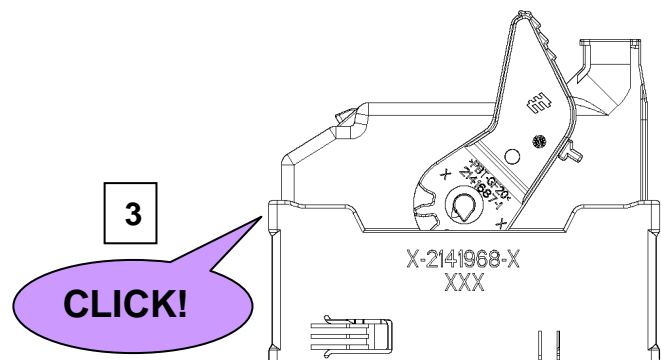

NOTE:

BEFORE MOUNTING THE COVER MAKE SURE THAT THE SLIDERS AND LEVER ARE AT PRE-LOCKED POSITION (DELIVERY CONDITION SHOWN ON CUSTOMER DRAWING).

2.4.2 COVER REMOVAL -APPLY TO BOTH 180° AND 90° WIRE COVERS-

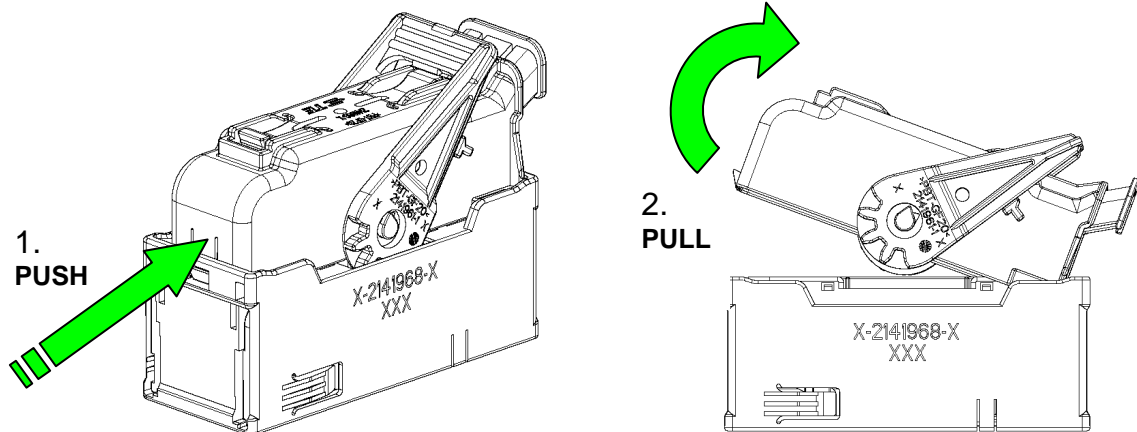

3 CONNECTOR MATING / UNMATING ON / FROM AGGREGATE HEADER -APPLY TO BOTH 180° AND 90° WIRE COVERS-

3.1 CONNECTOR MATING

NOTE:

BEFORE MATING THE CONNECTOR ON THE AGGREGATE HEADER MAKE SURE THAT THE LEVER IS AT PRE-LOCKED POSITION (DELIVERY CONDITION SHOWN ON CUSTOMER DRAWING).

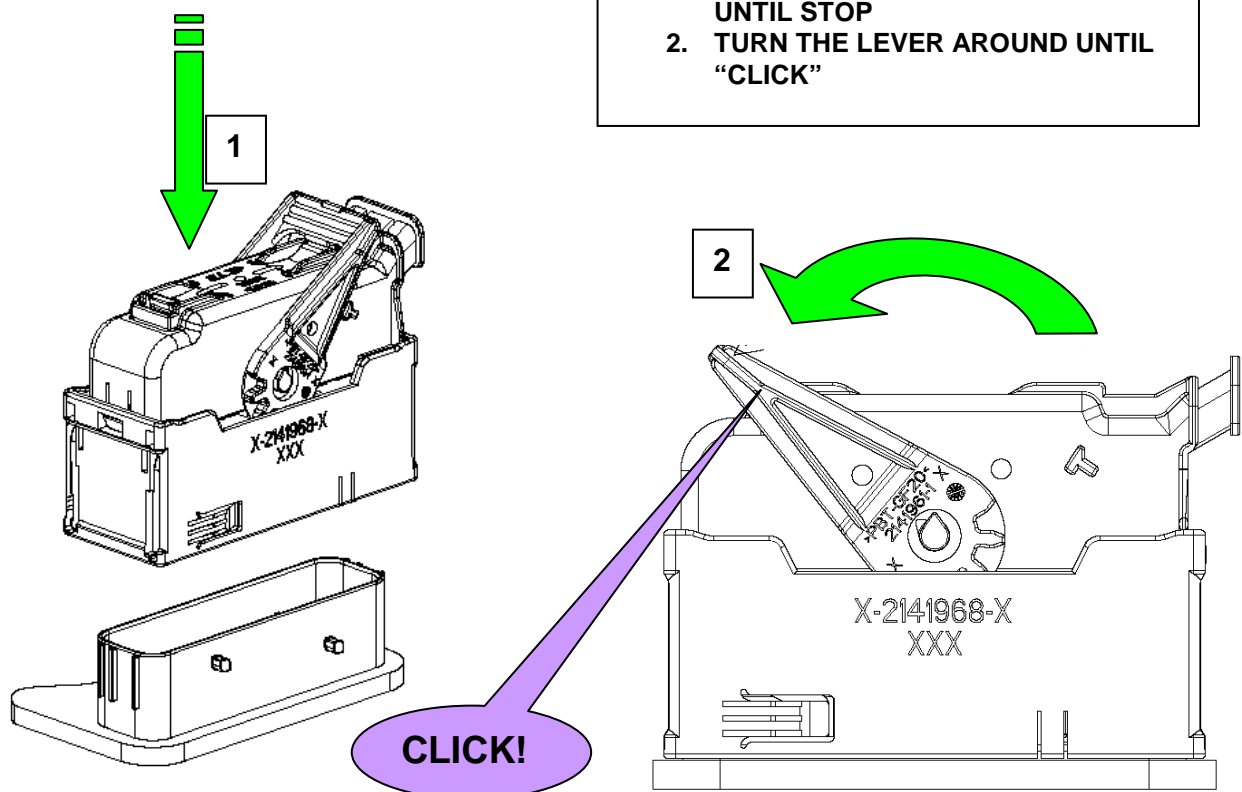

3.2 CONNECTOR UNMATING

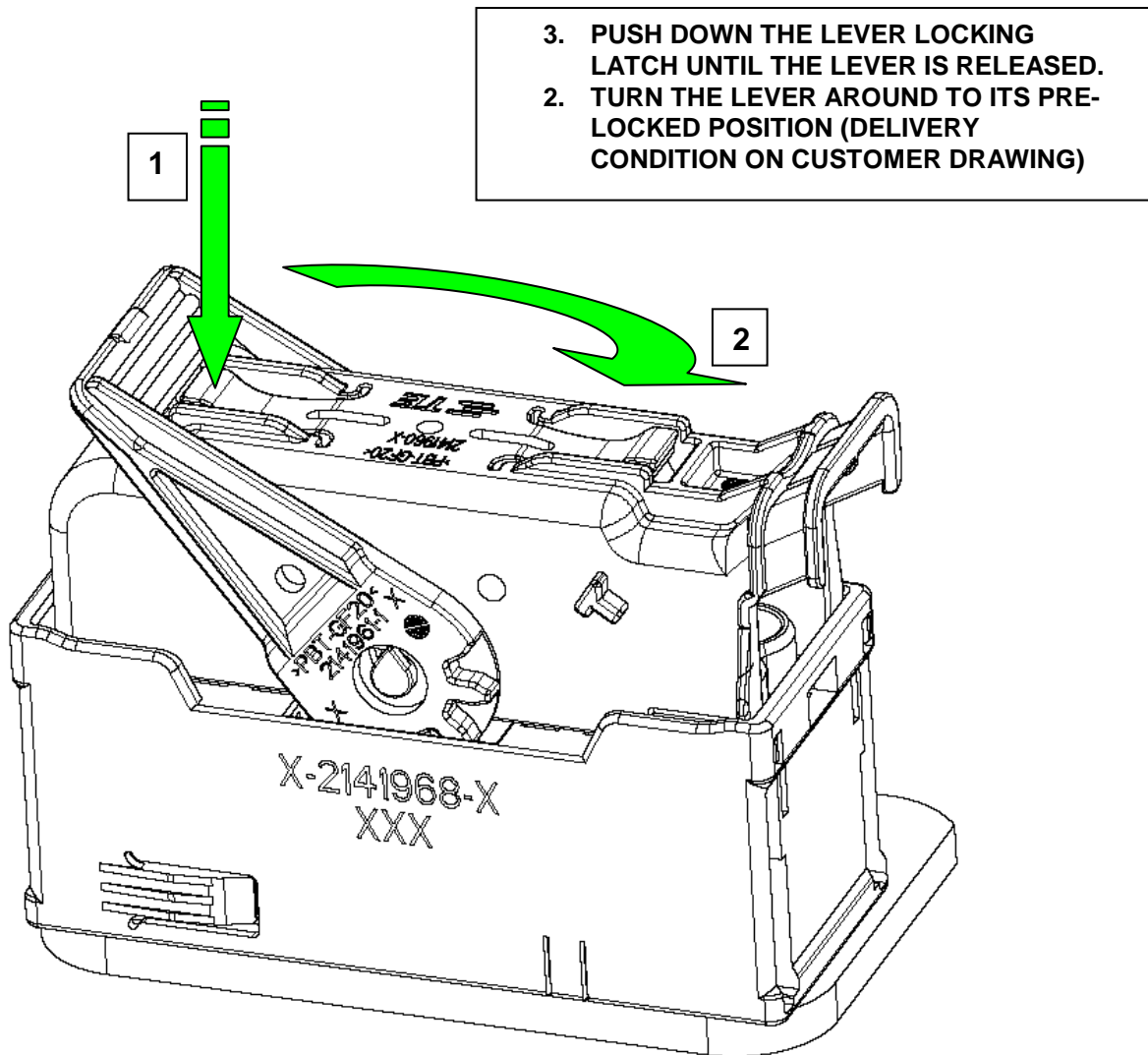

APPENDIX A

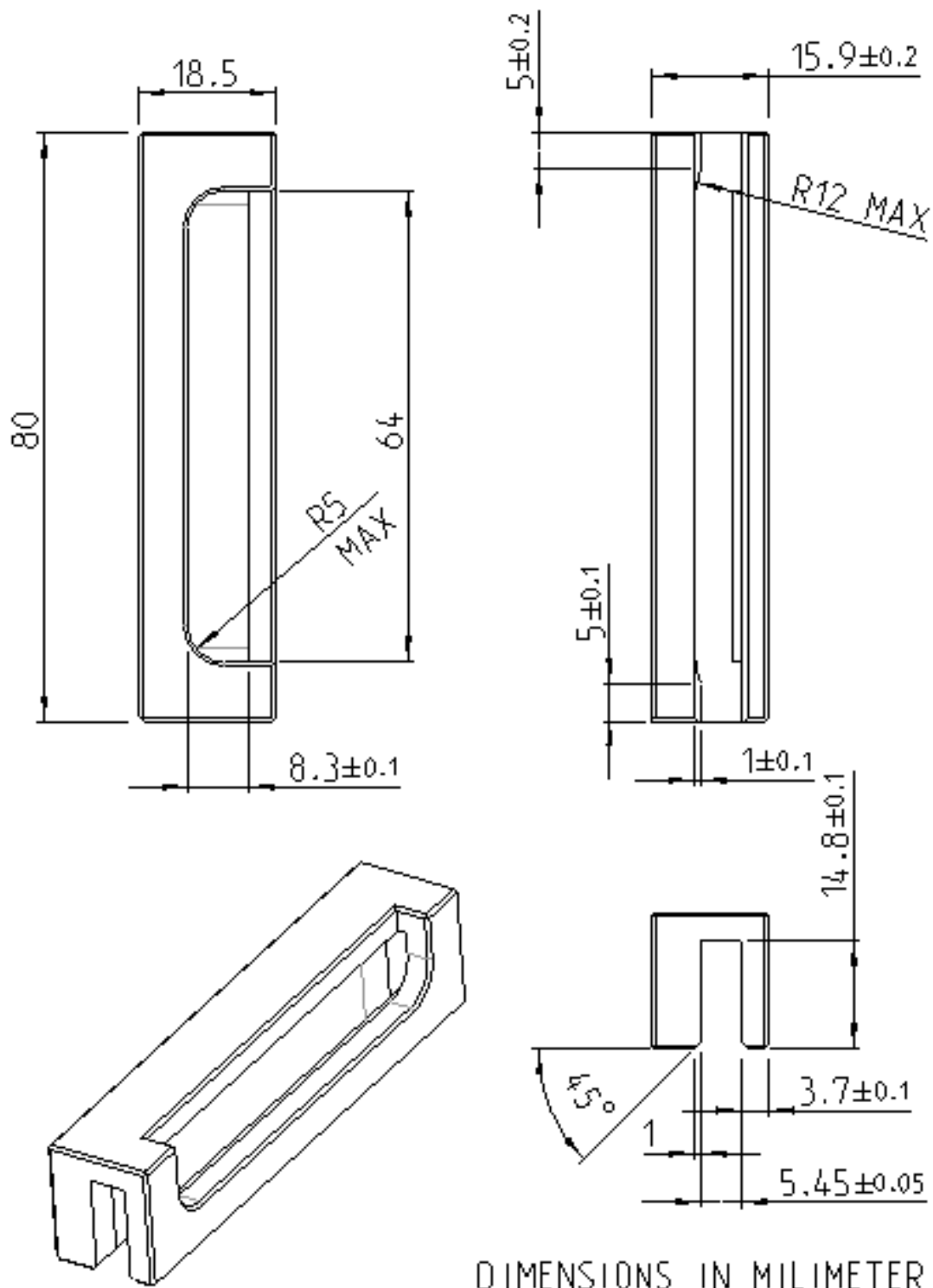

RECOMMENDED MATERIAL: ALUMINUM OR HARD PLASTIC