



HMN-HD-Keying Plug Series

Table of contents

1. INTRODUCTION	2
2. SUPPORTING DOCUMENTS	2
2.1. Customer drawings	2
2.2. Product specification	2
2.3. Application Specification	2
2.4. Standards	2
3. DESCRIPTION	3
4. ASSEMBLY	4
4.1. Applicable Insert	4
4.2. Assemble keying plug to insert	5
4.2.1. Pattern A	5
4.2.2. Pattern B	6
4.3 INSERTION PROCEDURE	7
4.3.1 Assemble keying plug to Insert	7
4.3.2 Broken off of keying plug carrier	7



1. INTRODUCTION

This specification contains the regulations for assembly of HMN-HD-Keying Plug.

2. SUPPORTING DOCUMENTS

2.1. Customer drawings

Please refer to the customer drawings of HMN-HD-Keying Plug.

2.2. Product specification

The product specifications of the used articles are to be considered. The product specification describes the technical data as e.g. regulations, approvals, temperature range and rated voltage.

2.3. Application Specification

Connectors shall be assembled as below mentioned application specifications to ensure correct connector assembly.

2.4. Standards

- EN 61984: Connectors - Safety requirements and tests

3. DESCRIPTION

This application specification describes the HMN-HD-Keying Plug.

The listed terms are used in the specification as shown HMN-HD1-48-M/F as example in figure 1.

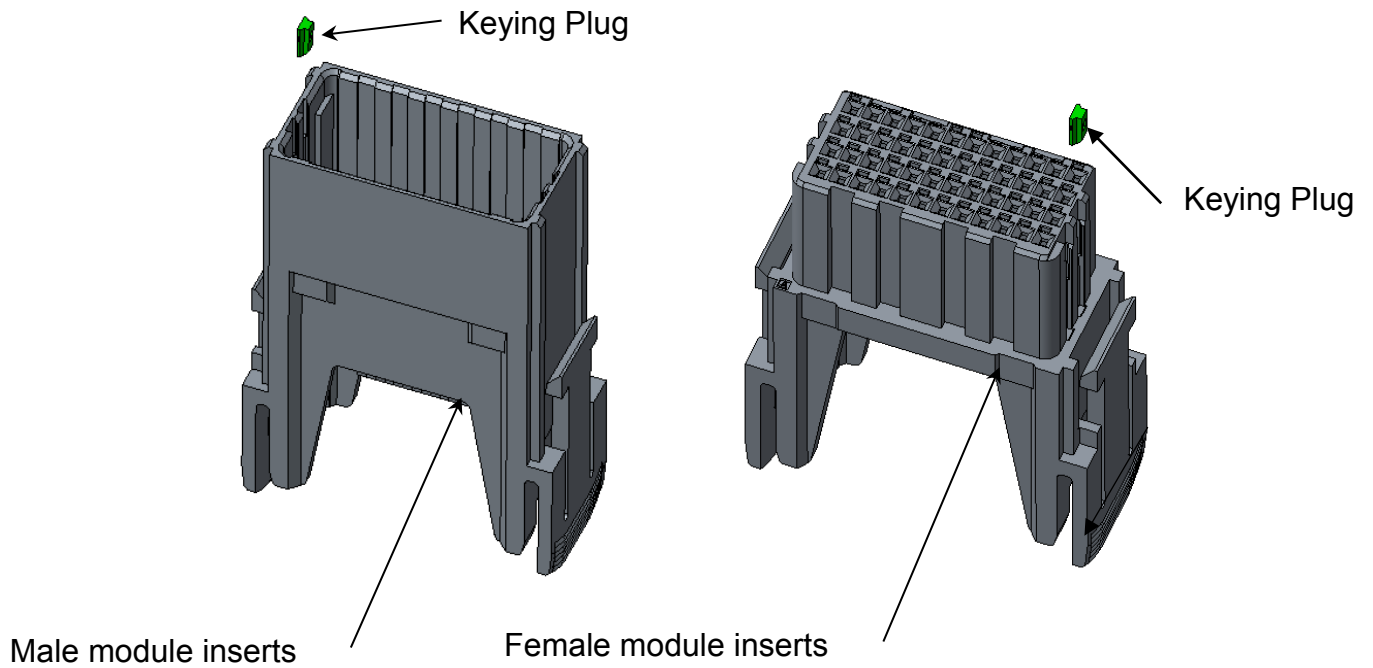

Figure: 1



4. ASSEMBLY

4.1. Applicable Insert

Please refer Table 1.

Table 1

Series Items	Insertion Pattern
HMN-HD1-48-M/F	A
HMN-HD1-24-M/F	A
HMN-HD3-10-M/F	A
HMN-HD4-6-M/F	A
HMN-HD5-3-M/F	A
HMN-HDW-5/3-4/4-M/F	B

4.2. Assemble keying plug to insert

4.2.1. Pattern A

The hole that is inserted keying plug is 4 positions (Figure 2). Each 2 keying plugs are inserted in Male and Female insert. Then, the keying combination is max 6 kinds. The combination refers Figure 3.

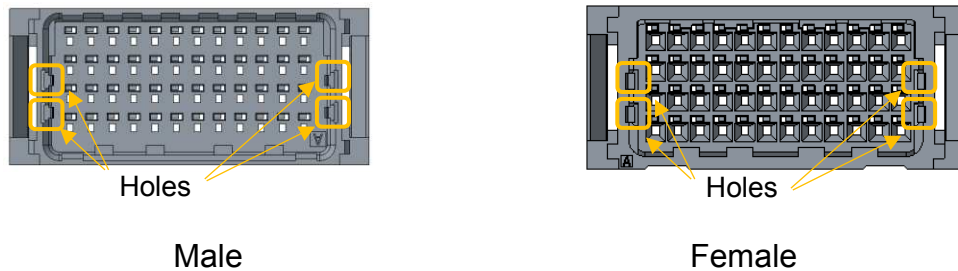

Figure: 2



Combination	Male	Female
1		
2		
3		
4		
5		
6		

Figure: 3

4.2.2. Pattern B

The hole that is inserted keying plug is 6 positions. 2 keying plugs are inserted in Male insert and 4 keying plugs are inserted in Female insert. Then, the keying combination is max 3 kinds. The combination refers Figure 4.

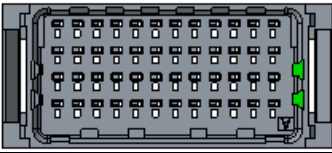
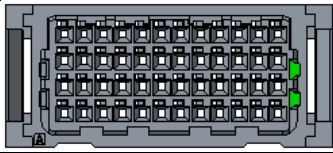
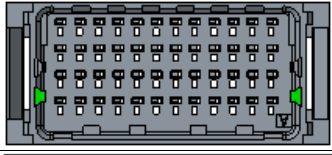
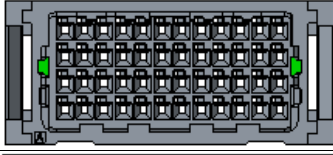
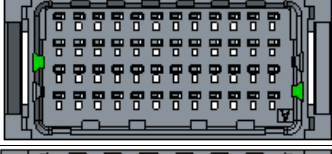
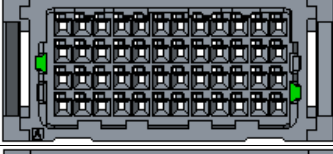
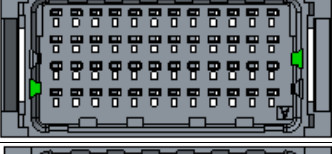
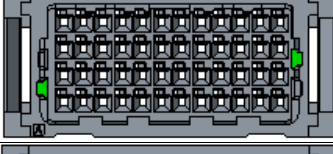
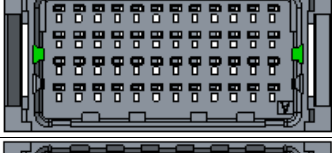
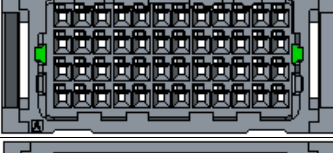
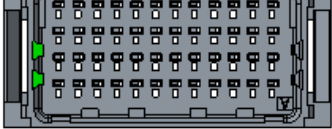
Combination	Male	Female
1		
2		
3		

Figure: 4

4.3 INSERTION PROCEDURE

4.3.1 Assemble keying plug to Insert

The keying plug are plugged into the module insert by gently pushing it into the required position until over specified area.

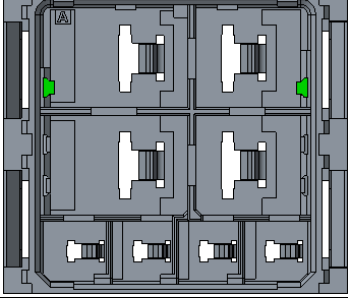
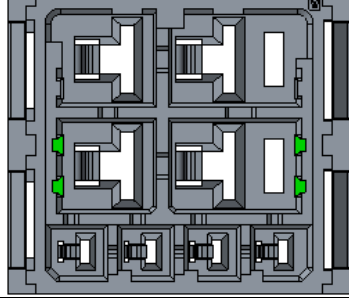
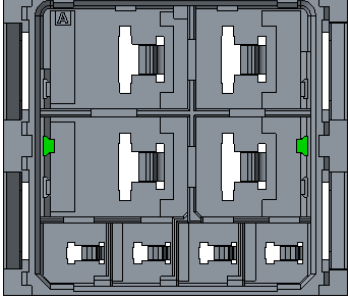
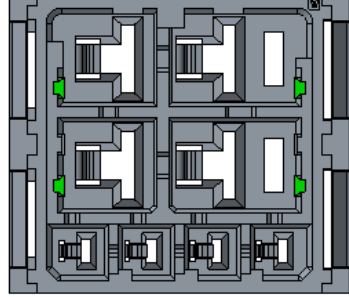
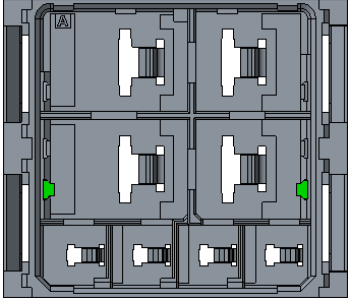
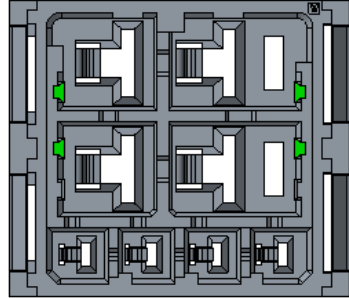
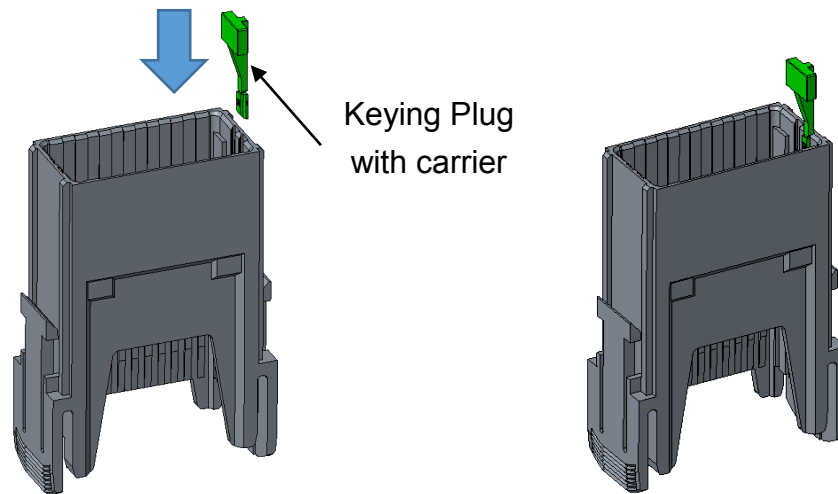

The depth of keying plug
Male

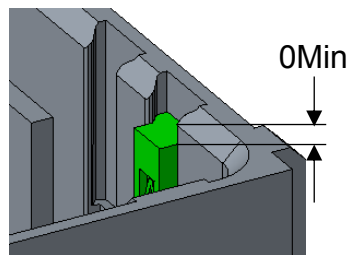

The depth of keying plug
Female

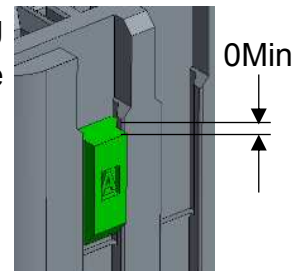

Figure: 5

4.3.2 Broken off keying plug carrier

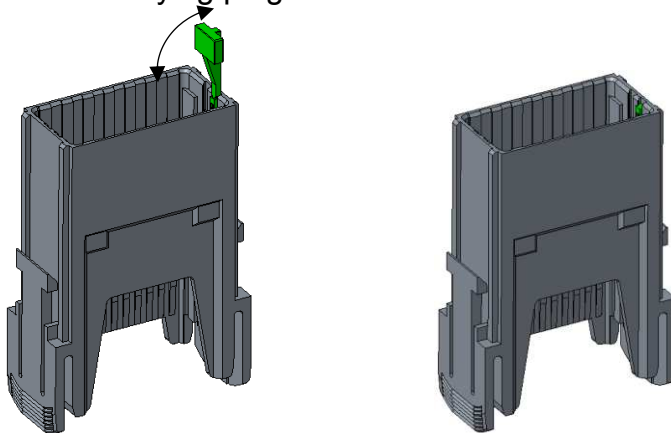

Figure: 6

-----END-----