

Sealed Industrial Ethernet Circular IP67 Cat. 5e RJ45 Connector System Assembly Instructions

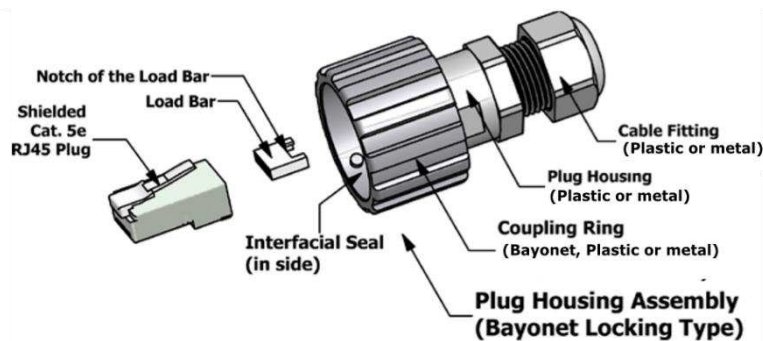
The Industrial Ethernet Circular Sealed RJ45 Connector System consists of a RJ45 Plug Kit, a Receptacle Kit and a Protective Cover Assembly.

1. The RJ45 Plug Kit

1.1 Introduction

The Cat. 5e RJ45 plug kit consists of a shielded 8 position Cat. 5e RJ45 Plug, a Load Bar and a Plug Housing Assembly (Bayonet). There are 2 different versions available for the Plug Housing Assembly, plastic and Metal. The RJ45 plug accepts both stranded and solid cables. It can be IDC terminated with the termination tool. The load bar aligns the wires for insuring easy and proper assembly.

Fig. 1.1. RJ45 Plug Kit



2. ETHERNET CABLE

The following specified category 5e 100Ω shielded and unshielded twisted pair cables (STP and UTP) and Cat. 6A Screened shielded twisted pair (SSTP) cables are suitable for use with the RJ45 Plug Kit. Plastic version of the cable fitting accepts cables with an outer diameter range of 4mm to 8mm while 4.5mm to 8mm for the metallized plastic version.

A. STRANDED WIRE OF CAT. 5E CABLE

- Cable type: 8 positions
- Conductor size: 24 AWG
- Conductor type: 7 strand copper
- Contact insulator diameter: 0.99mm maximum
- RJ45 plug accepts cable outer diameter range: 4.83mm ~ 6.73mm

B. SOLID WIRE OF CAT. 5E CABLE

Cable type: 8 positions
Conductor size: 24 AWG
Conductor type: copper
Contact insulator diameter: 0.99mm maximum

C. STRANDED WIRE OF CAT. 6A CABLE

Cable type: 8 positions
Conductor size: 26 AWG
Conductor type: 7 strand copper
Contact insulator diameter: 0.99mm maximum
RJ45 plug accepts cable outer diameter range: 4.83mm ~ 6.73mm

D. SOLID WIRE OF CAT. 6A CABLE

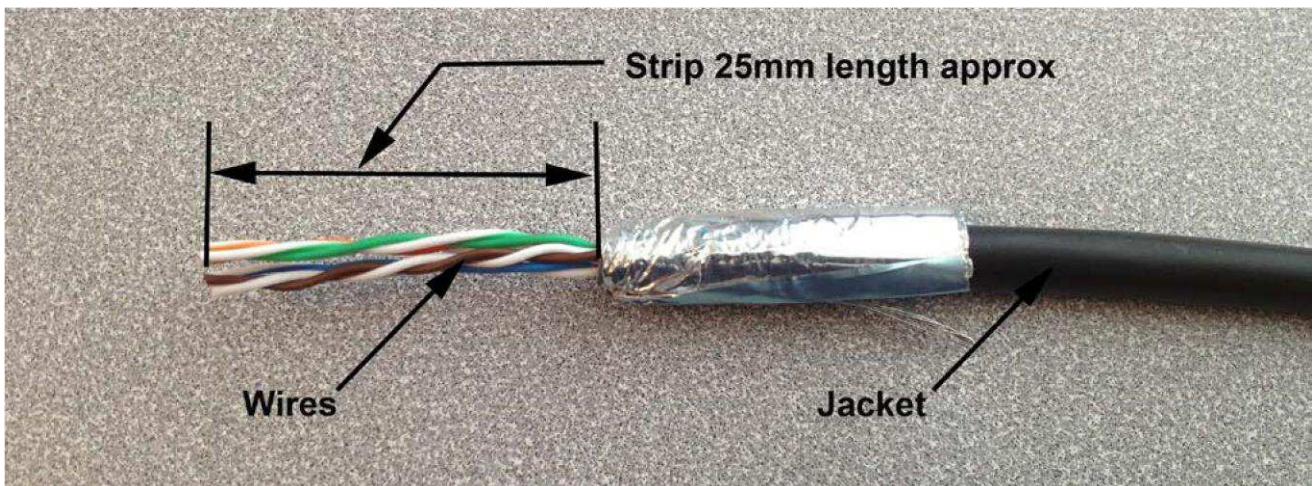
Cable type: 8 positions Conductor
size: 26 AWG
Conductor type: copper
Contact insulator diameter: 0.99mm maximum

RJ45 plug accepts Loose, Pliable cable outer diameter range: 4.83mm ~ 6.73mm RJ45 plug accepts
Hard, Rigid cable outer diameter range: 4.83mm ~ 5.08mm

2.1 Cable Preparation

2.1.1 Cable jacket should be stripped with the proper length as shown in figure 2-1 and then inserted through the cable fitting and the plug housing assembly.

figure. 2.1 Cable Preparation Step 1



2.1.2 Conductor pair should be untwisted and aligned side-by-side according to EIA/TIA **T568A** or **T568B** (defined in Figure 2-2 and Table 1-1) and the conductor tips should be trimmed as shown in Figure 2-3. Please note that insulation of individual conductors must not be removed.

Figure 2-2 EIA/TIA T568A & T568B

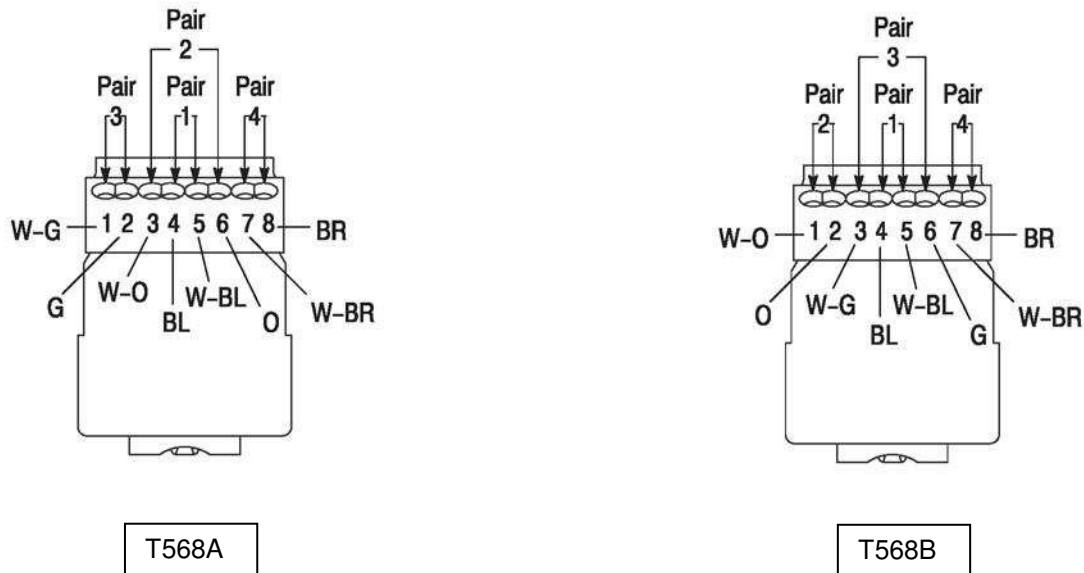
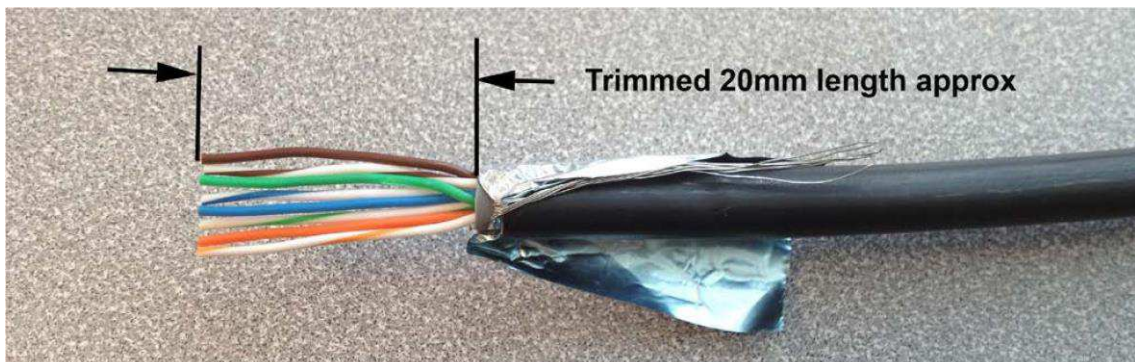


Table 1-1: TIA/EIA T568A & T568B Conductor Pairs and Wire Colors

Conductor Pair	Conductor Pair Definitions		Wire Color Code (Abbreviation)	
	T568A	T568B	Option 1	Option 2
Pair 1	4	4	Blue (BL)	Red (R)
	5	5	White-Blue(W-BL)	Green (G)
Pair 2	3	1	White-Orange (W-O)	Black (BK)
	6	2	Orange (O)	Yellow (Y)
Pair 3	1	3	White-Green (W-G)	Blue (BL)
	2	6	Green (G)	Orange (O)
Pair 4	7	7	White-Brown (W-BR)	Brown (BR)
	8	8	Brown (BR)	Slate (S)

Figure 2-3: Cable Preparation Step 2

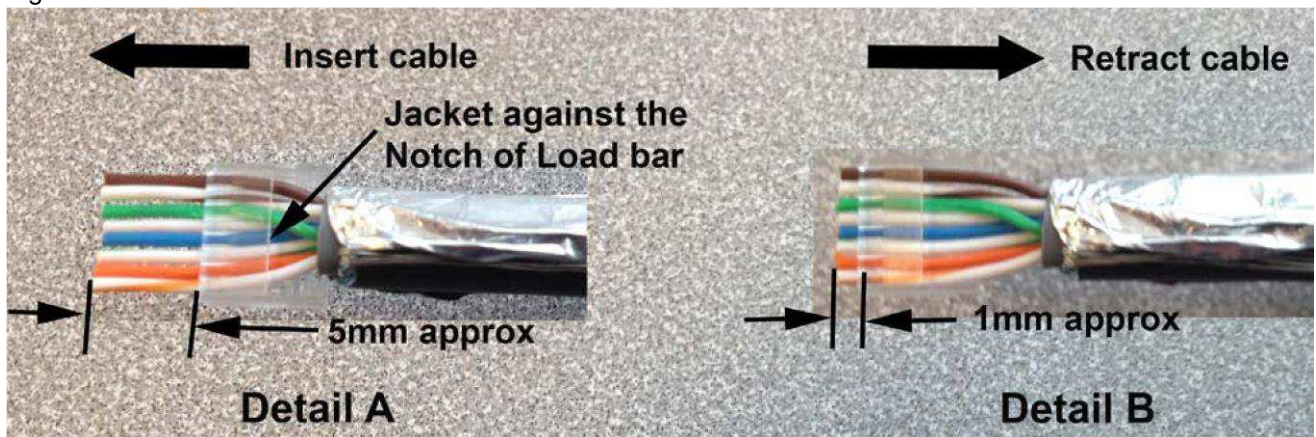


2.2 Termination

2.2.1 Cat. 5e RJ45 Plug Termination

2.2.1.1 After inserting the wires into the appropriate positions of the load bar, slide the cable to a point where the cable jacket hits against the notch of the load bar. Trim the remaining wire ends to approximately 5mm length of the wire tips as shown in **Detail A** of Figure 2-4. Retract the cable, leaving about 1mm length of the wire tips as shown in **Detail B** of Figure 2-4.

Figure 2-4: Insert Conductors into the Load bar

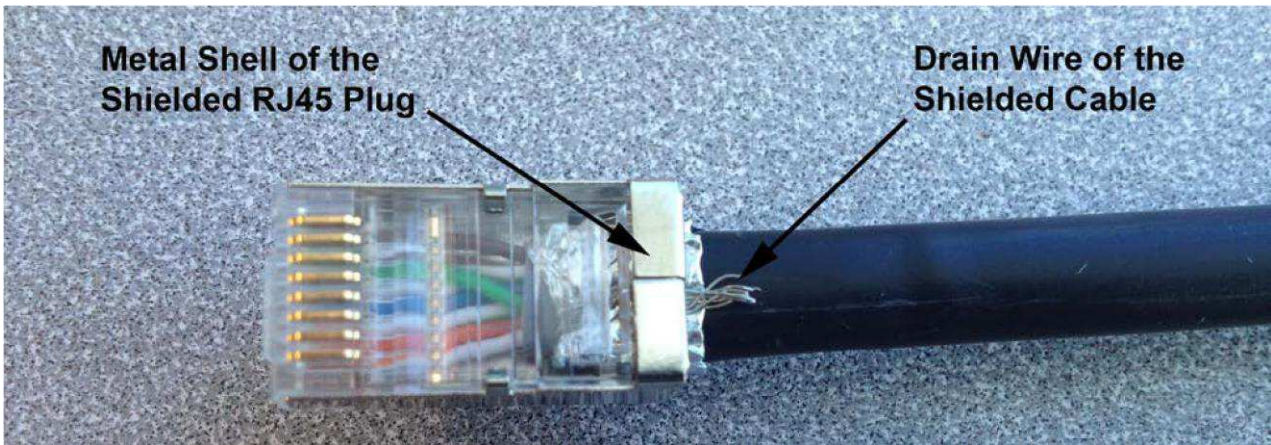


2.2.1.2 Insert the wired load bar into the RJ45 plug all the way until the wire tips are seated against the inside wall of the plug housing (Figure 2-5). For shielded version adjust the drain wires of the cable to touch the metal shell of the RJ45 Plug (Figure 2-6). Cut out extra drain wire after termination.

Figure 2-5: Insert the wired load bar into plug

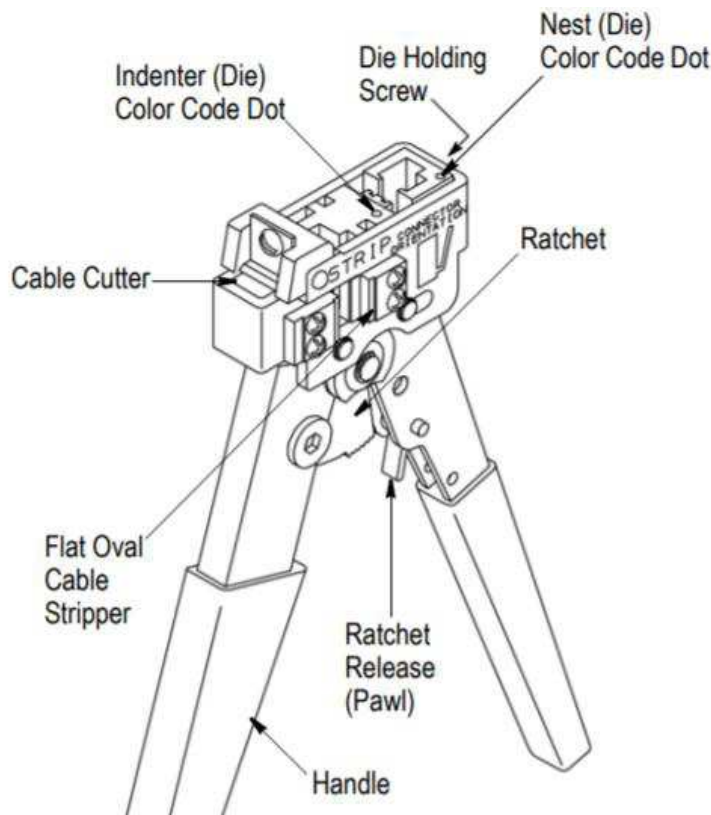


Figure 2-6: Place the drain wire of the cable to touch the metal shell of the shielded plug



2.2.3 Terminate the cable and the RJ45 Plug with a modular plug termination tool like TE pn. x-231652-x (Figure 2-7). For more details on how to use this hand tool and to which die sets have to be used follow detailed instructions on instruction sheet no. 408-09767.

Figure 2-7 Modular Plug Termination Tool

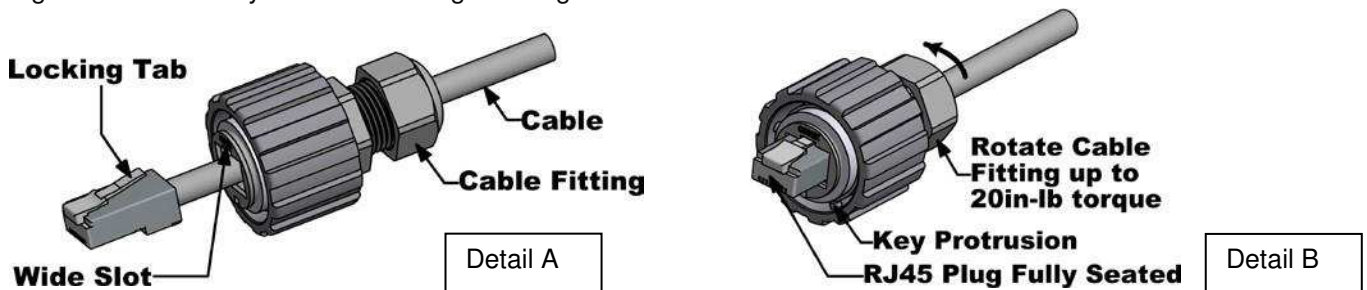


2.2.4 After cable termination it is advised to use a network cable tester to verify the pin configuration

3 ASSEMBLY OF THE RJ45 PLUG HOUSING

Depress the locking tab of RJ45 Plug and align it with the wide slot of the plug housing shown in **Detail A** of Figure 3-1. Gently pull the cable until the plug is fully seated. Hold the plug in position and rotate the cable fitting until tightened to a torque of 2.27 Nm (20 lb-in). See **Detail B** of Figure 3-1.

Figure 3-1: Assembly of the RJ45 Plug Housing

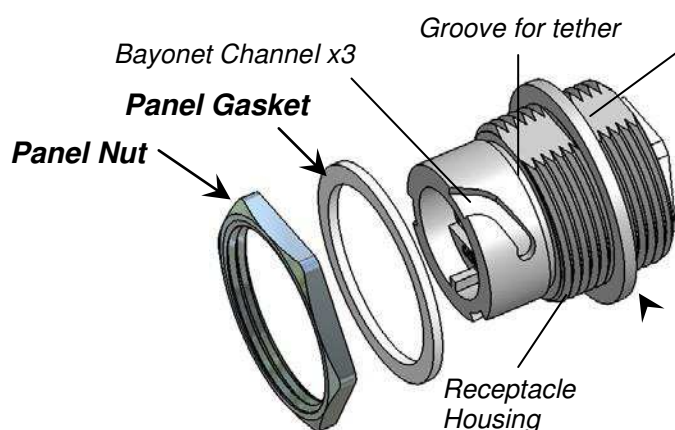


4. THE RECEPTACLE ASSEMBLY KIT

4.1 The Cat. 5e RJ45 Inline Coupler Receptacle Assembly Kit

This Receptacle Assembly kit consists of a **RJ45 Inline Coupler Receptacle Assembly**, a **Panel Gasket** and a **Panel Nut**. There are plastic and metal versions available for the receptacle Housing.

Figure 4-1: Cat. 5e RJ45 Inline Coupler Receptacle Assembly Kit

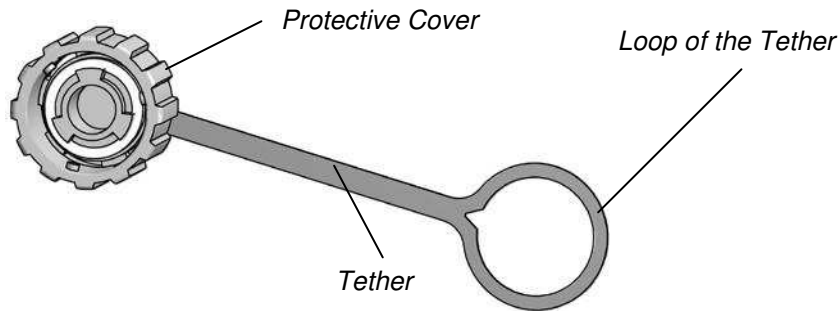


5 PROTECTIVE COVER ASSEMBLY

5.1 Introduction

The **Protective Cover Assembly** consists of a *Cover Coupling Ring*, a *Cover Gasket* and a *Tether*. There are plastic and metal versions available for the *Cover Coupling Ring* housing.

Figure 5-1: Protective Cover Assembly



6 PANEL CUTOUT

6.1 Introduction

A panel thickness of up to 3.20 mm may be used. The recommended panel cutout dimension for plastic, metallized plastic and metal versions are shown in Figure 6-1 while Figure 6-2 is the recommended panel cutout dimension for zinc die-cast version and Figure 6-3 is the recommended panel cutout dimension for flange mount zinc die-cast version.

Figure 6-1: Recommended Panel Cutout for Plastic and Metal Version

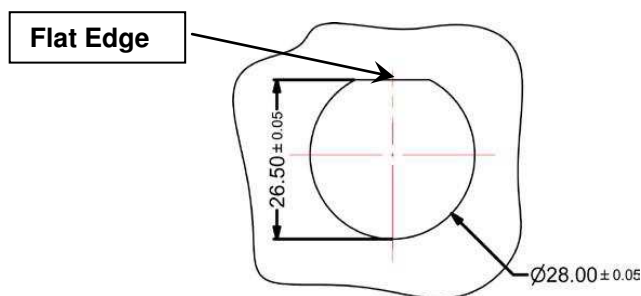


Figure 6-2: Recommended Panel Cutout for Zinc Die-Cast version

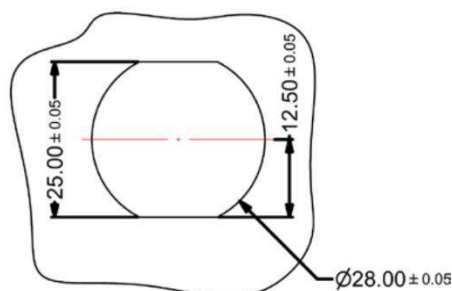
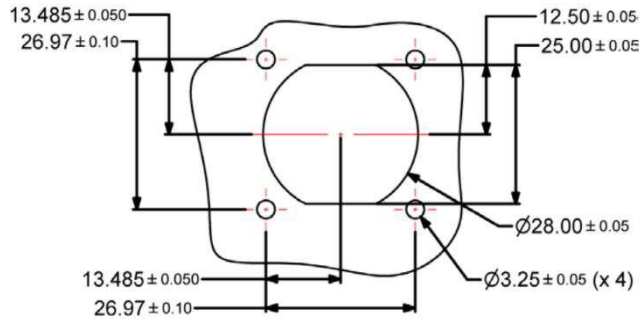


Figure 6-3: Recommended Panel Cutout for Flange Mount Zinc Die-Cast version

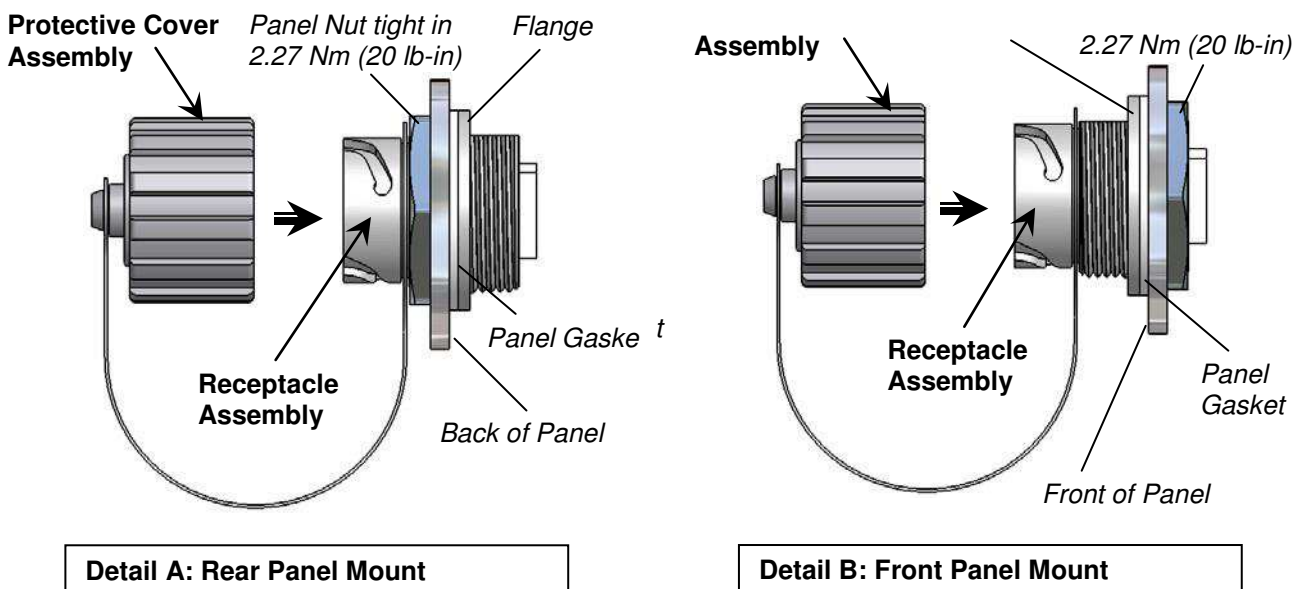


6.2 Panel Mounting

The receptacle is designed for front or rear panel mounting as shown in **Detail B** and **Detail A** of Figure 8-2. The panel nut should be tightened to a torque of 2.27 Nm (20 lb-in).

The **Protective Cover** must be installed onto the **Receptacle Assembly** and cover the receptacle immediately for insuring the IP67 sealing performance once the **Plug Assembly** is removed from the receptacle.

Figure 6-2: The Receptacle Panel Mounting



7 CONNECTOR ENGAGEMENTS

7.1 RJ45 Jack and Plug Engagement (Bayonet)

Gently insert the assembled plug (Bayonet) into the Jack adaptor of the RJ45 receptacle, align the 3 keys of the bayonet coupling ring with 3 bayonet channels of the receptacle and rotate the bayonet coupling ring until the 3 keys “click” into the bayonet channels. See **Detail A** of Figure 7-1.

7.2 RJ45 Jack and Plug Engagement (Cable Strain Relief)

Gently insert the assembled plug (Thread) into the Jack adaptor of the RJ45 receptacle then fully thread the M28 coupling ring. See **Detail B** of the Figure 7-1.

7.3 Protective Cover Engagement

The protective cover must be installed onto the **Receptacle Assembly** and engaged with the receptacle immediately for insuring IP67 sealing performance whenever the **Plug Assembly (Bayonet)** is removed from the **Receptacle Assembly**.

The tether of the protective cover should be attached to the **Receptacle Assembly** if it is to be used. Place the loop of the tether in the groove (located between the end of the bayonet channels and the hex nut) of the **Receptacle Assembly**. See **Detail C** of Figure 7-1.

Figure 7-1: Connector Engagement

