



NOTE

All numerical values are in metric units [with U.S. customary units in brackets]. Dimensions are in millimeters. Unless otherwise specified, dimensions have a tolerance of ± 0.13 and angles have a tolerance of $\pm 2^\circ$. Figures and illustrations are for identification only and are not drawn to scale.

1. INTRODUCTION

This specification covers the requirements for application of Rail M12 cable assemblies and CSCs for free hanging and panel mounting applications. The cable assembly and connectors are designed for use in Rail equipment and control, signal, and electrical appliances. The cable assembly and connectors have an ingress protection rating of IP67.

The connectors are available as field installable with screw termination and panel mount available with wires. The connectors consist of a female (socket) and a male (plug) and are available in unshielded or shielded and straight or angled. The cable assembly is available in single ended and double ended with straight and angle connectors.

When corresponding with personnel, use the terminology provided in this specification to facilitate inquiries for information. Basic terms and features of this product are provided in Figure 1.

Rail M12 general layouts

Male



Female



Rail M12 D Code 4 position cable mounting



Rail M12 D Code 4 position bulk head



Figure 1

Rail M12 D Code 4 position without shield**Figure 1****2. REFERENCE MATERIAL****2.1. Revision Summary**

Initial release of application specification

2.2. Customer Assistance

Reference Product Base Part Numbers 2823445,2823446,2823447,2823448,2823449,2823450 (Cable assembly) and Product Code M308 are representative of Rail M12 cable assemblies and CSCs. Use of these numbers will identify the product line and help you to obtain product and tooling information. Such information can be obtained through a local Representative, by visiting our website at www.te.com, or by calling PRODUCT INFORMATION or the TOOLING ASSISTANCE CENTER at the numbers at the bottom of page 1.

2.3. Drawings

Customer Drawings for product part numbers are available from the service network. If there is a conflict between the information contained in the Customer Drawings and this specification or with any other technical documentation supplied, the information contained in the Customer Drawings takes priority.

2.4. Specifications

Product Specification 108-156001 provides product performance and test results.

2.5. Instructional Material

Instruction Sheets (408-series) provide product assembly instructions. Instructional material available that pertain to this product are:

- [408-156003](#) M12, D-Coded 4-Position cable mount
- [408-156020](#) M12, D-Coded 4-Position bulkhead cable mount
- [408-156021](#) M12, D-Coded 4-Position without shield
- [408-156022](#) M12, A-Coded 5-Position cable mount
- [408-156023](#) M12, A-Coded 8-Position bulkhead cable mount
- [408-156024](#) M12, A-Coded 8-Position without shield

2.6. Standards and Publications

Standards and publications developed by the International Electro technical Commission (IEC) provide industry test and performance requirements. Standards available that pertain to this product are:

All parts were qualified according to tests relating to IEC 61076-2-101

Thread of the mating interface with the counterpart is M12x1, according to IEC 61076-2-101.

Shock and vibration conducted as per IEC 61373:1999.

Fire performance conducted as per EN45545-2, NFF16-101 and NFF16-102.

3. REQUIREMENTS

3.1. Storage

A. Ultraviolet Light

Prolonged exposure to ultraviolet light may deteriorate the chemical composition used in the product material.

B. Shelf Life

The product should remain in the shipping containers until ready for use to prevent deformation to components. The product should be used on a first in, first out basis to avoid storage contamination that could adversely affect performance.

C. Chemical Exposure

Do not store product near any chemical listed below as they may cause stress corrosion cracking in the material.

Alkalies	Ammonia	Citrates	Phosphates	Citrates	Sulfur Compounds
Amines	Carbonates	Nitrites	Sulfur Nitrites		Tartrates

3.2. Operating Temperature

The cable assemblies and connectors must be used within the operating temperature given on the customer drawing for the specific connector

3.3. Cable Selection

The connectors accept cable having the requirements given on the specific connector customer drawing. In this specification, when the connector assembly procedure depends on the cable shield outer diameter, that diameter is included in the assembly requirements of Paragraph 3.4.

3.4. Cable Preparation and Connector Assembly

A. Rail M12 Field Installable Connectors

These connectors must meet the cable preparation and connector assembly requirements given in **Instructional Material 2.5**.

B. Cable Assembly

The cable of the cable assembly must remain perpendicular to the connector and avoid an excessively sharp bend radius. The minimum bend radius of a cable is $\pm 10^\circ$.

3.5. Panel

A. Recommended Thickness and Cutout

The maximum panel thickness shall be 4.0. The recommended panel cutouts are given in Figure 2.

B. Indexing

There are two rotational orientations for mounting the connector to the panel: top/bottom and left/right. This orientation must be chosen before creating the cutout in the panel.

Recommended panel cut-out for Rail M12 Connectors (Customer can choose any one of the panel cut-out).

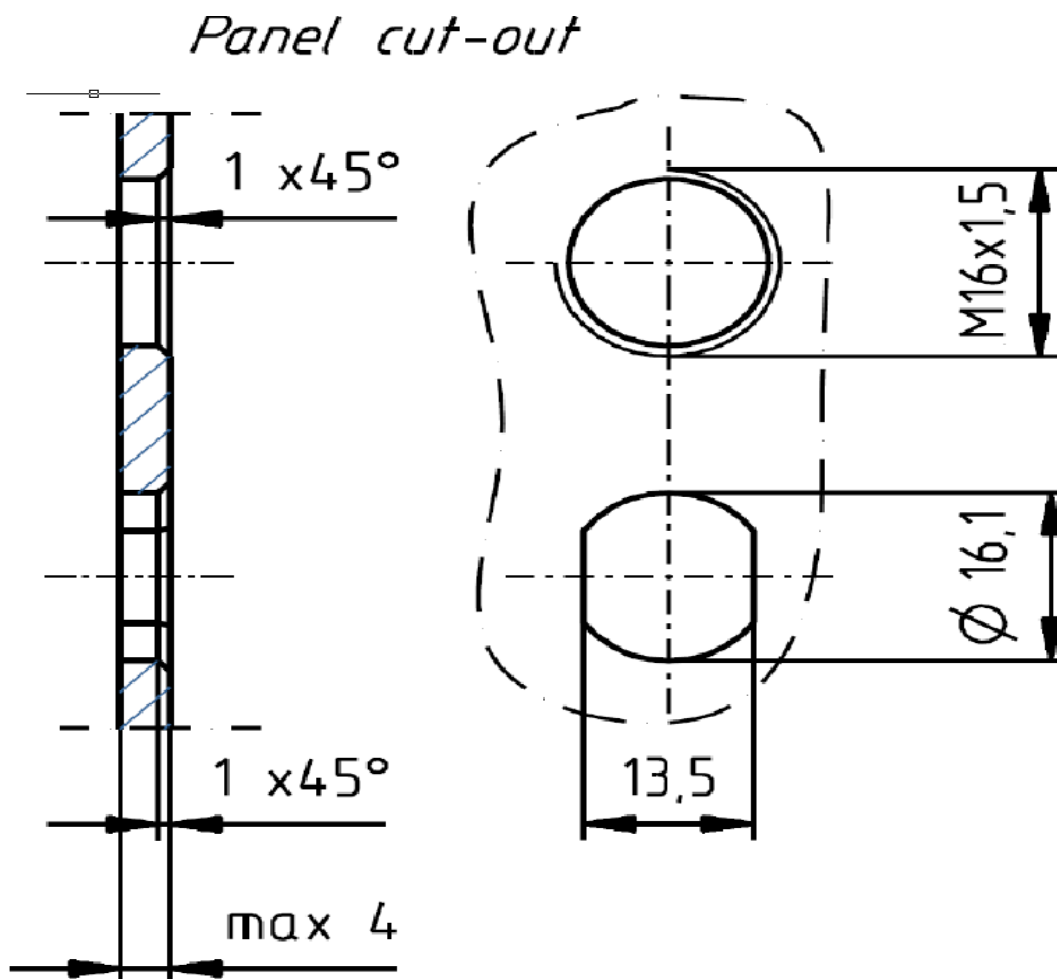

Figure 2

C. Mounting

The connector is designed to be front or rear panel mounted. The mounted connector must meet the following requirements:

- the flat of the connector must be aligned with the flat edge cut in the panel
- the O-ring or gasket must be between the flange and the panel
- the gasket must be flat against the panel
- the panel nut must be flat against the panel and tight to the torque given in figure 3

SCREW TYPE Rail M12	TORQUE (Nm [ft-lb])
	6.25 [4.6]

Figure 3

3.6. Mating and Unmating



DANGER

To avoid personal injury, these connectors and cable assemblies must not be mated or unmated under live conditions (electrical load).

The recommended torque for mating Rail M12 connectors: 0.8Nm

3.7. Replacement and Repair

These cable assemblies and connectors are not repairable. Damaged or defective components must not be used. Connectors must not be re-used by removing the cable.

Fitting and servicing should only be performed by qualified personnel in accordance with all guidelines and standards.

4. TOOLING

Rail M12 cable assemblies tooling details refer **Instructional Material 2.5**.

5. VISUAL AID

The illustration in **Instructional Material 2.5** shows a typical application of Rail M12 cable assemblies and CSCs. This illustration should be used by production personnel to ensure a correctly applied product. Applications which do not appear correct should be inspected using the information in the preceding pages of this specification and in the instructional material shipped with the product or tooling.