

# IP68 Hood and Housing Series

## Table of contents

- 1. INTRODUCTION ..... 2
- 2. SUPPORTING DOCUMENTS ..... 2
  - 2.1. Customer drawings ..... 2
  - 2.2. Product specification ..... 2
  - 2.3. Application Specification ..... 2
  - 2.4. Standards ..... 2
- 3. DESCRIPTION ..... 3
  - 3.1. Assembly product ..... 3
  - 3.2. Hood and housing types ..... 4
    - 3.2.1. Central locking ..... 4
      - 3.2.1.1. Normal type ..... 4
      - 3.2.1.2. Hood \_Front side entry ..... 5
      - 3.2.1.3. Hood \_High construction ..... 5
      - 3.2.1.4. Housing \_With Gasket ..... 6
      - 3.2.1.5. Housing \_Surface mounting ..... 6
      - 3.2.1.6. Housing \_Surface mounting ..... 7
      - 3.2.1.7. Hood & Housing \_Conductive version ..... 7
    - 3.2.2. Opposite angle locking ..... 8
      - 3.2.2.1. Normal type ..... 8
      - 3.2.2.2. Hood \_Front side entry ..... 9
      - 3.2.2.3. Hood \_Two top entry ..... 9
      - 3.2.2.4. Hood \_Three top entry ..... 10
      - 3.2.2.5. Hood \_Three top entry ..... 10
      - 3.2.2.6. Housing \_Surface mounting ..... 11
      - 3.2.2.7. Protection Cover ..... 11
- 4. REQUIREMENTS ..... 12
  - 1.2. Panel cut-out ..... 12
- 5. ASSEMBLY ..... 15
- 6. STORAGE ..... 21

## 1. INTRODUCTION

This specification contains the regulations for assembly of various IP68 Hood and Housing.

The following components are available in this system:

Hood and housing: H6BPR/H10BPR/H16BPR/H24BPR.

## 2. SUPPORTING DOCUMENTS

### 2.1. Customer drawings

For dimensions and materials of the individual parts, please refer to the relative customer drawings of H6BPR/H10BPR/H16BPR/H24BPR.

### 2.2. Product specification

The product specifications of the used articles are to be taken into account. The product specification describes the technical data as regulations, temperature range and degree of protection. For further reference, please refer to product spec. 108-137014.

### 2.3. Application Specification

Connectors shall be assembled as below mentioned application specifications to ensure correct connector assembly.

### 2.4. Standards

- EN 61984: Connectors - Safety requirements and tests
- IEC 60664-1: Insulation coordination for equipment within low-voltage systems (Part 1)
- EN 60529: Degrees of Protection Provided by Enclosures (IP Code)
- EN 60068: Environmental testing

## 3. DESCRIPTION

### 3.1. Assembly product

The following picture (Figure 1) shows an example of complete assembly product.

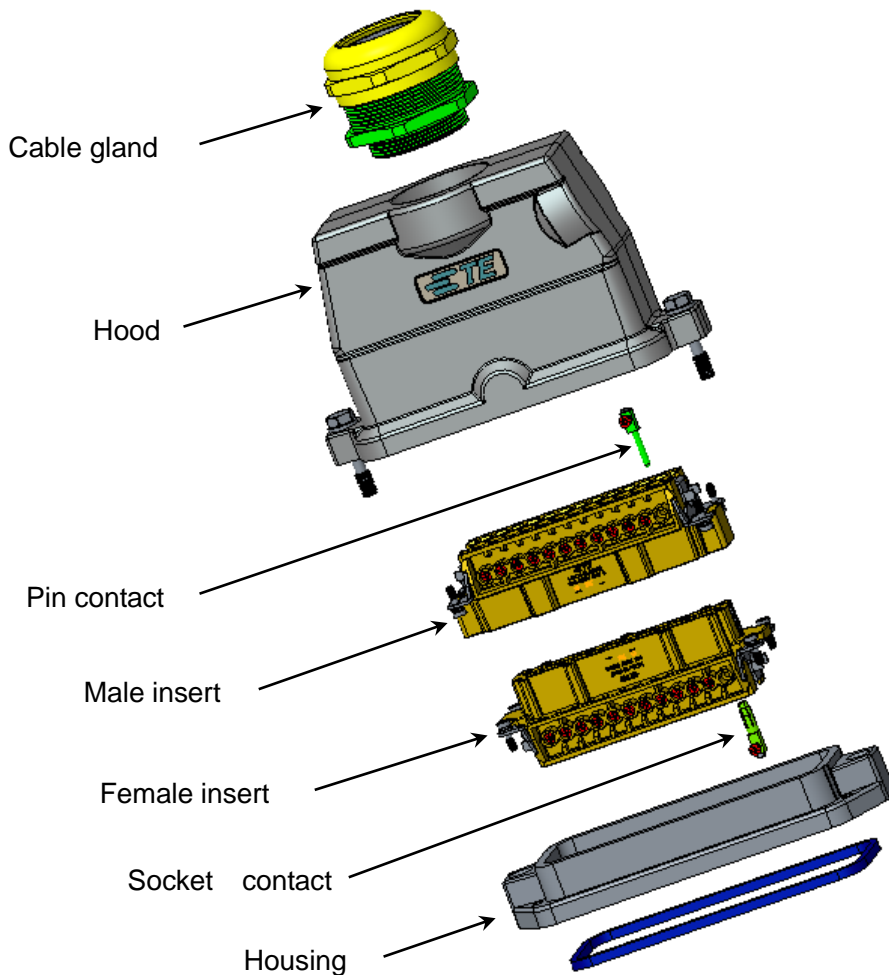

Figure: 1

The complete product consists of the following components (see figure 1):

- Cable gland
- Hood
- Pin contact
- Male insert
- Female insert
- Socket contact
- Housing

## 3.2. Hood and housing types

### 3.2.1. Central locking

#### 3.2.1.1. Normal type

Hood:

- HXXBPR-TSHC-PG/M
- HXXBPR-TGHC- PG/M
- HXXBPR-TS/GHC- PG/M

Housing:

- HXXBPR-AGC

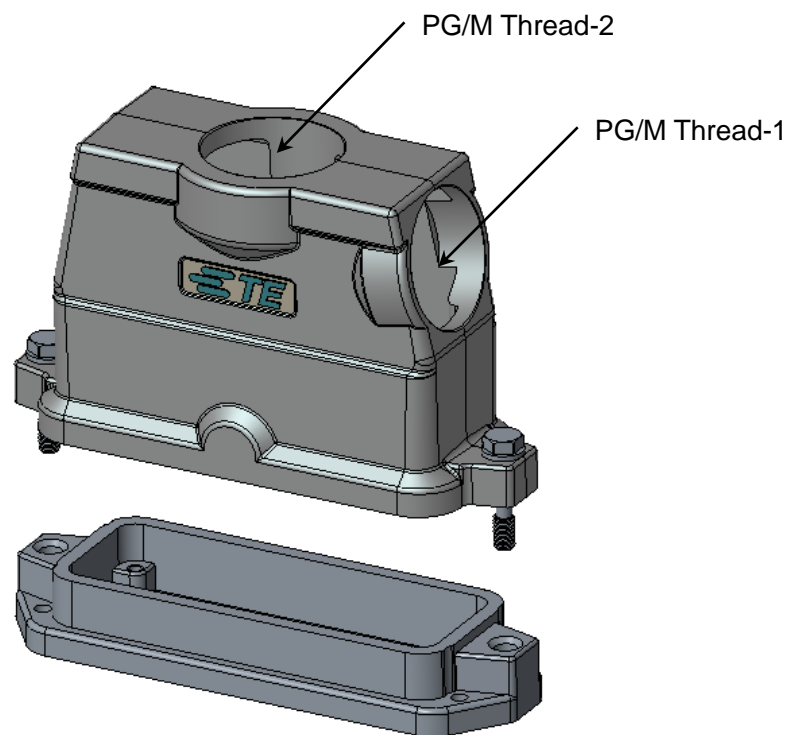

Figure: 2

- Hood & housing available for size: H6B,H10B, H16B, H24B
- PG/M Thread-1 optional: Blank, PG16,PG21,PG29,PG36,M20,M25,M32,M40
- PG/M Thread-2 optional: Blank, PG16,PG21,PG29,PG36,M20,M25,M32,M40

Note: Different hood& housing size has different optional PG/M Thread-X. Refer to drawings for detailed information.

## 3.2.1.2. Hood \_Front side entry

- HXXBPR-SGRHC-PG/M

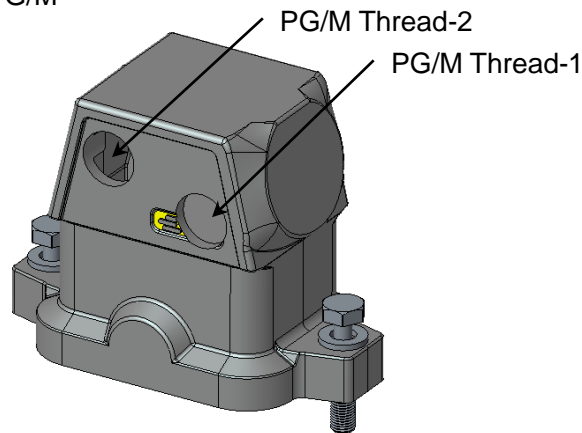

Figure: 3

- Hood available for size, Ex.: H6B
- PG/M Thread-1 optional: Blank, M16
- PG/M Thread-2 optional: Blank, M16

Note: Different hood size has different optional PG/M Thread-X. Refer to drawings for detailed information.

## 3.2.1.3. Hood \_High construction

- HXXBPR H130 -TG/SHC-PG/M

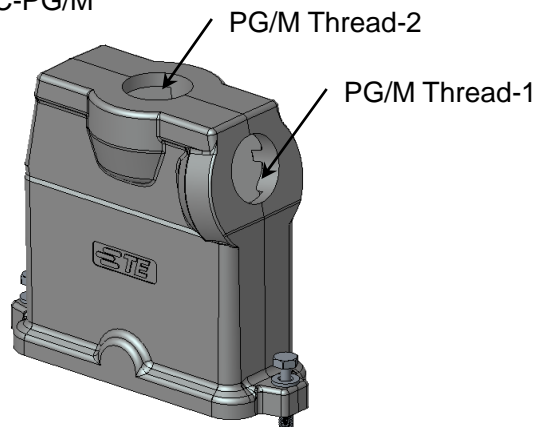

Figure: 4

- Hood available for size, Ex.: H24B
- PG/M Thread-1 optional: Blank, G16,PG21,PG29,PG36,M20,M25,M32,M40,M50
- PG/M Thread-2 optional: Blank, G16,PG21,PG29,PG36,M20,M25,M32,M40,M50

Note: Different hood size has different optional PG/M Thread-X. Refer to drawings for detailed information.

## 3.2.1.4. Housing \_With Gasket

- HXXBPR-AGC

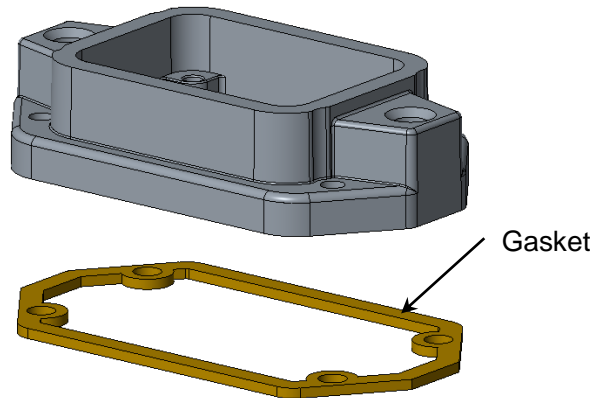

Figure: 5

- Housing available for size: H6B, H10B, H16B, H24B
- Gasket available for size: H6B, H10B, H16B, H24B

## 3.2.1.5. Housing \_Surface mounting

- HXXBPR-SGRHC-PG/M

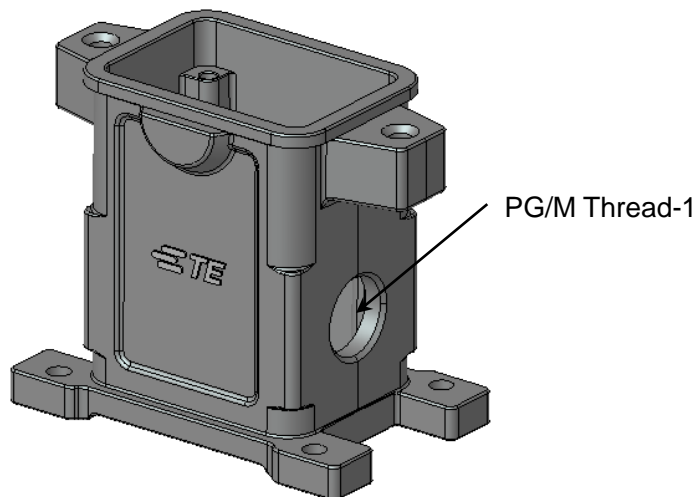

Figure: 6

- Housing available for size, Ex.: H6B
- PG/M Thread-1 optional: Blank, PG16, PG21, M16, M20, M25

Note: Different housing size has different optional PG/M Thread-X. Refer to drawings for detailed information.

### 3.2.1.6. Housing \_Surface mounting

- HXXBPR-AGCT

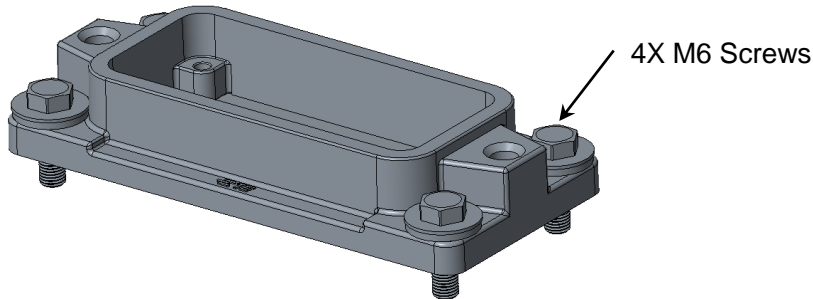

Figure: 7

- Housing available for size, Ex.: H16B

### 3.2.1.7. Hood & Housing \_Conductive version

- Seal: Conductive seal

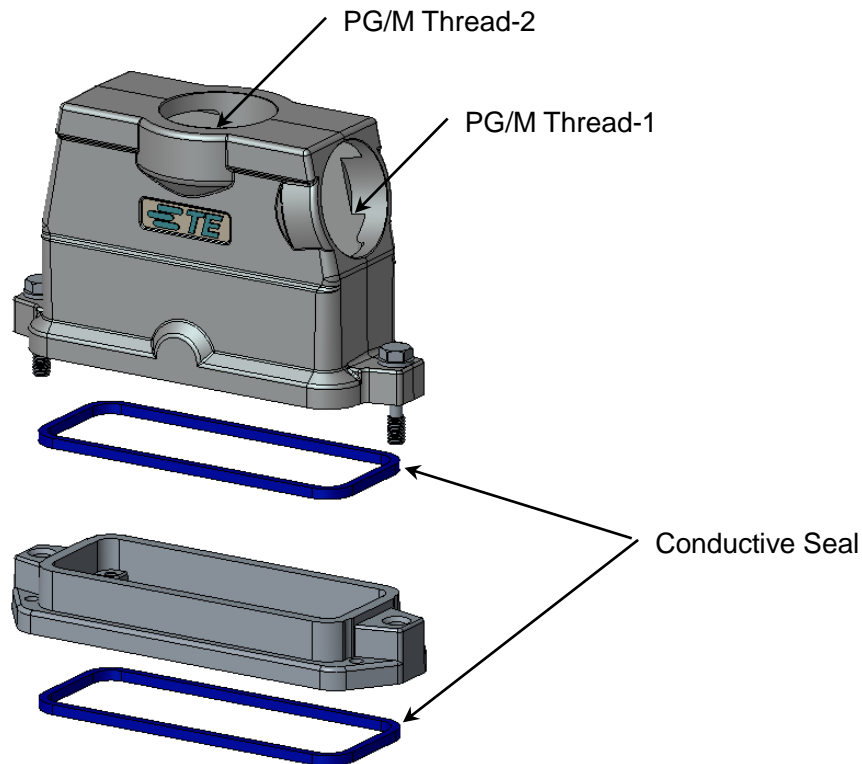

Figure: 8

- Hood & Housing available for size, Ex.: H24B
- Conductive seal available for size, Ex: H24B
- PG/M Thread-1 optional: Blank, PG16,PG21,PG29,PG36,M20,M25,M32,M40
- PG/M Thread-2 optional: Blank, PG16,PG21,PG29,PG36,M20,M25,M32,M40

Note: Different housing size has different optional PG/M Thread-X. Refer to drawings for detailed information.

## 3.2.2. Opposite angle locking

### 3.2.2.1. Normal type

Hood:

- HXXBPR-TSH-PG/M
- HXXBPR-TGH- PG/M
- HXXBPR-TS/GH- PG/M

Housing:

- HXXBPR-AG

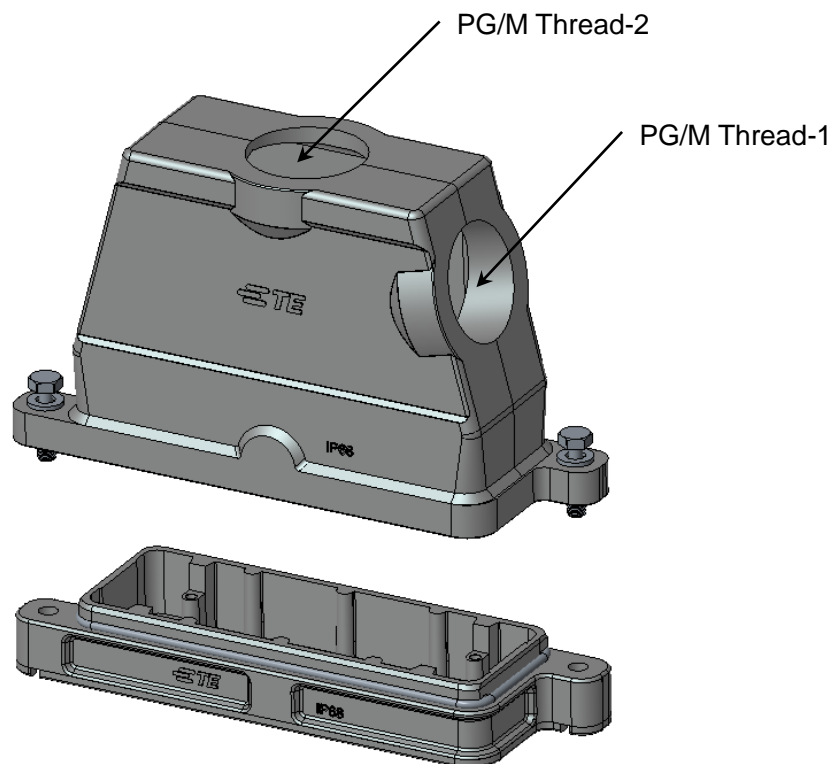

Figure: 9

- Hood & Housing available for size: H6B,H10B, H16B, H24B
- PG/M Thread-1 optional: Blank, PG16,PG21,PG29,PG36,M20,M25,M32,M40
- PG/M Thread-2 optional: Blank, PG16,PG21,PG29,PG36,M20,M25,M32,M40

Note: Different housing size has different optional PG/M Thread-X. Refer to drawings for detailed information.



### 3.2.2.2. Hood \_Front side entry

- HXXBPR-TFH-PG/M

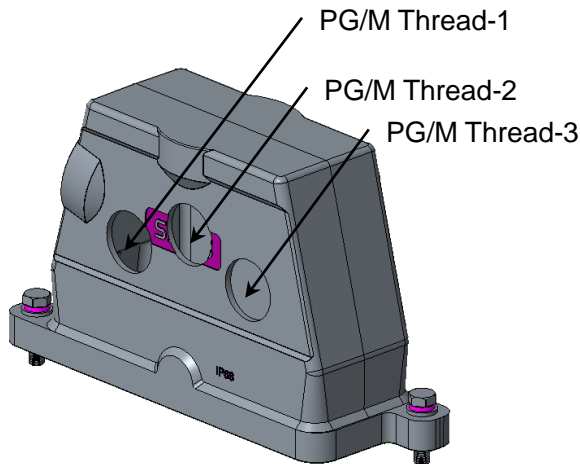

Figure: 10

- Hood available for size, Ex: H24B
- PG/M Thread-1 optional: Blank, PG16,PG21,M20,M25
- PG/M Thread-2 optional: Blank, PG16,PG21,M20,M25
- PG/M Thread-3 optional: Blank, PG16,PG21,M20,M25

Note: Different housing size has different optional PG/M Thread-X. Refer to drawings for detailed information.

### 3.2.2.3. Hood \_Two top entry

- HXXBPR-TGH-PG/M

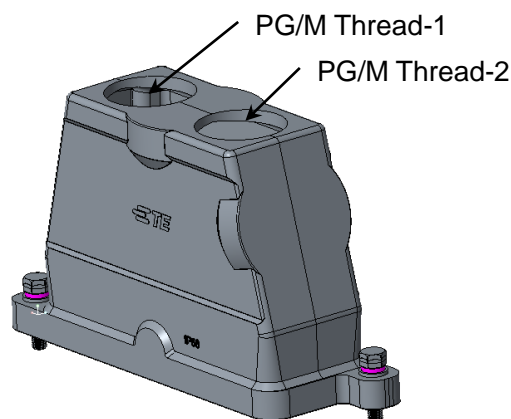

Figure: 11

- Hood available for size, Ex.: H10B,H16B,H24B
- PG/M Thread-1 optional: Blank, PG16,PG21,PG29,M20,M25,M32,M40
- PG/M Thread-2 optional: Blank, PG16,PG21,PG29,M20,M25,M32,M40

Note: Different housing size has different optional PG/M Thread-X. Refer to drawings for detailed information.

## 3.2.2.4. Hood \_Three top entry

➤ HXXBPR-TGH-PG/M

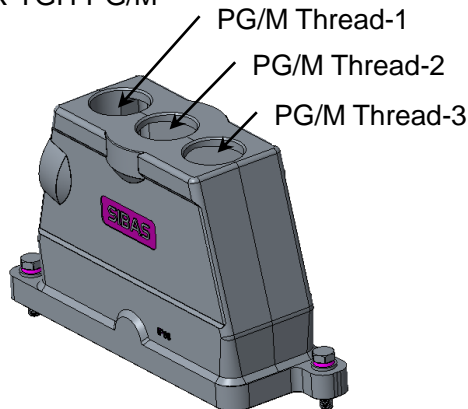

Figure: 12

- Hood available for size, Ex.: H24B
- PG/M Thread-1 optional: Blank, PG16,PG21,M20,M25
- PG/M Thread-2 optional: Blank, PG16,PG21,M20,M25
- PG/M Thread-3 optional: Blank, PG16,PG21,M20,M25

Note: Different housing size has different optional PG/M Thread-X. Refer to drawings for detailed information.

## 3.2.2.5. Hood \_Three top entry

➤ HXXBPR-TGH-PG/M

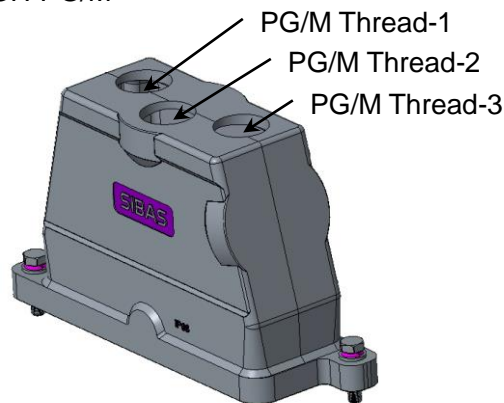

Figure: 13

- Hood available for size, Ex.: H24B
- PG/M Thread-1 optional: Blank, PG16,PG21,M20,M25
- PG/M Thread-2 optional: Blank, PG16,PG21,M20,M25
- PG/M Thread-3 optional: Blank, PG16,PG21,M20,M25

Note: Different housing size has different optional PG/M Thread-X. Refer to drawings for detailed information.

## 3.2.2.6. Housing \_Surface mounting

- HXXBPR-SGRH-PG/M

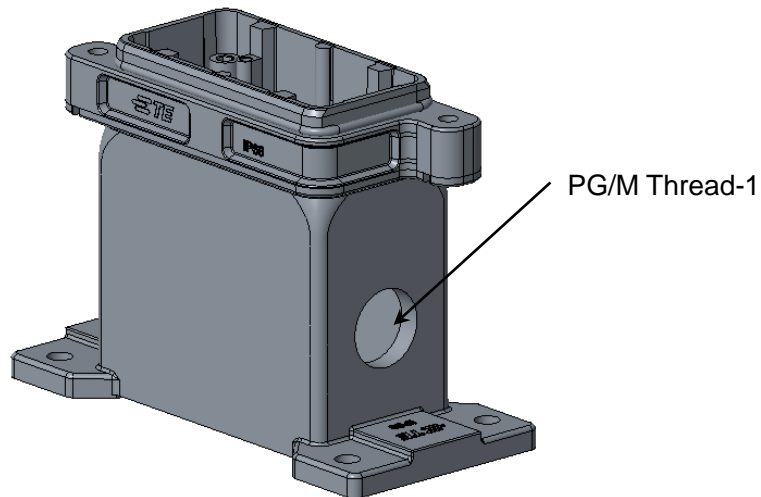

Figure: 14

- Hood available for size, Ex.: H10B
- PG/M Thread-1 optional: Blank, PG16,PG21,PG29,M20,M25,M32

Note: Different housing size has different optional PG/M Thread-X. Refer to drawings for detailed information.

## 3.2.2.7. Protection Cover

- HXXBPR-KDB

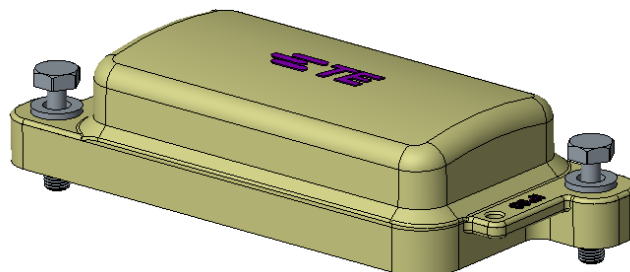

Figure: 15

- Protection Cover available for size: H6B,H10B, H16B, H24B

## 4. REQUIREMENTS

### 1.2. Panel cut-out

- For housing types other than surface mounted

More detailed information also can be found from related customer drawings.

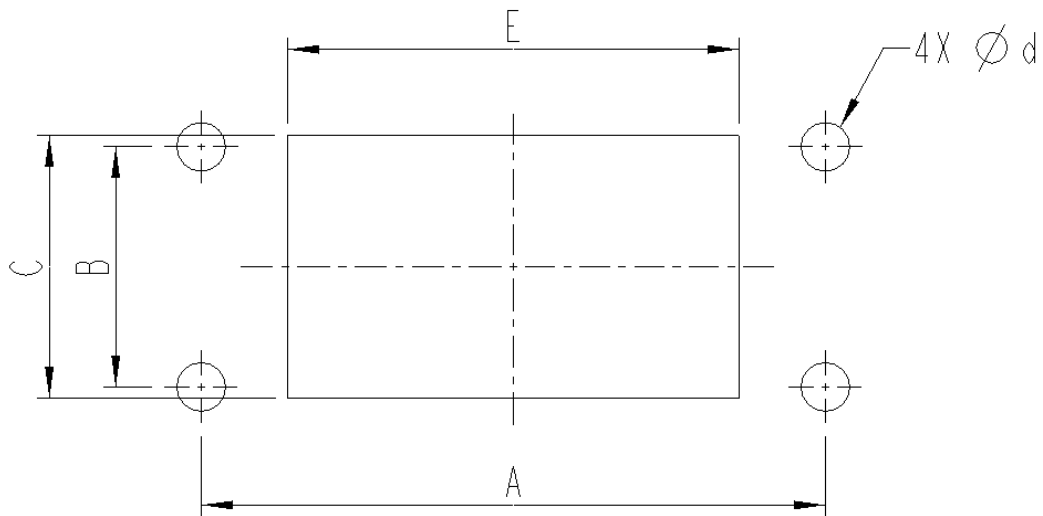

**Figure: 16**

Housing size	Dimension (mm)					
	A	B	C	d		E
				Central locking	Opposite angle locking	
H6B	70	32	35	For M4 screw	For M6 screw	48
H10B	83	32	35	For M4 screw	For M6 screw	60
H16B	103	32	35	For M4 screw	For M6 screw	82
H246B	130	32	35	For M4 screw	For M6 screw	108

- For surface mounted housings  
HXXBPR-SGRH-PG/M  
HXXBPR-SGRHC-PG/M  
Information also can be found from related customer drawings.

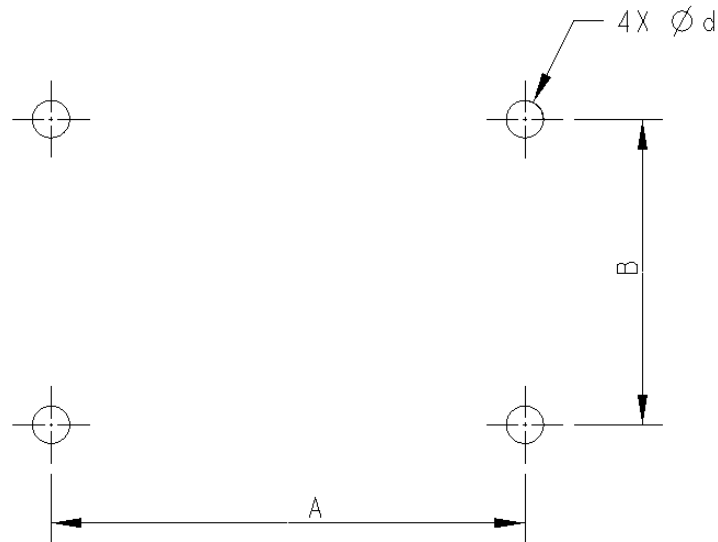

**Figure: 17**

	Housing size	Dimension (mm)			
		A	B	d	
				Central locking	Opposite angle locking
HXXBPR-SGRHC-PG/M	H6B	70	45	For M5 screw	-
HXXBPR-SGRH-PG/M	H10B	140	60	-	For M8 screw

- For surface mounted housings  
HXXBPR-AGCT  
Information also can be found from related customer drawings.

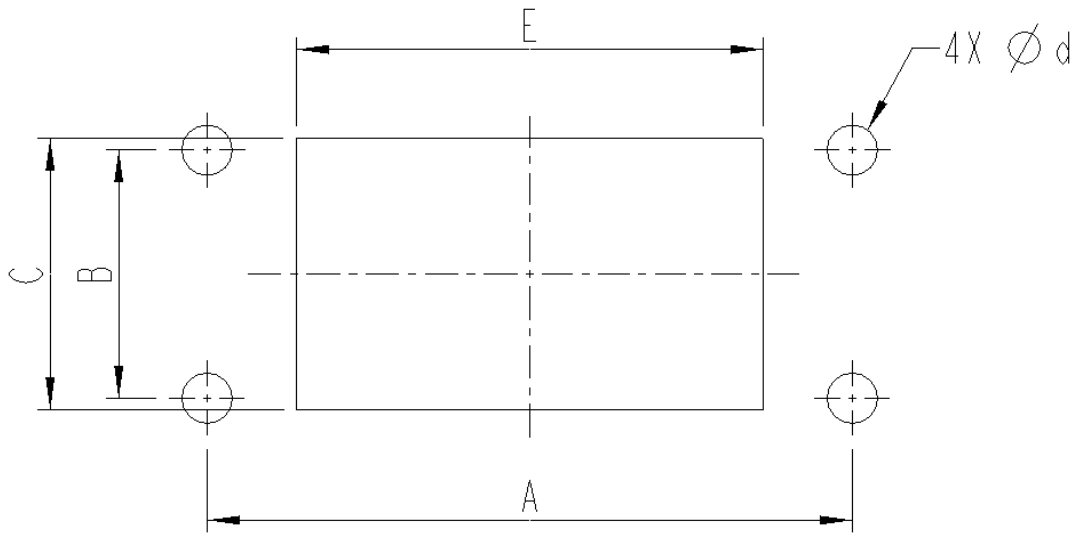

**Figure: 18**

Housing size	Dimension (mm)				
	A	B	C	d	E
H16B	112.5	35	43	For M6 screw	82

## 5. ASSEMBLY

### ➤ Assembly housing

#### For central locking

Fix housing with 4 x M4 screws. Tightening torque refer to spec of screws, but no less than 2Nm.

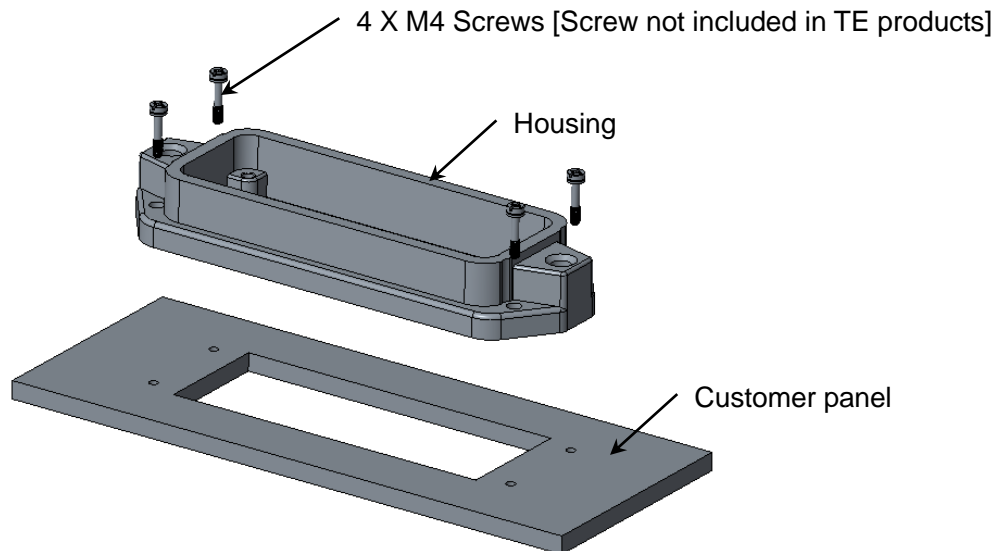

Figure: 19

#### For opposite angle locking

Fix housing with 4 x M6 screws. Tightening torque refer to spec of screws, but no less than 4Nm.

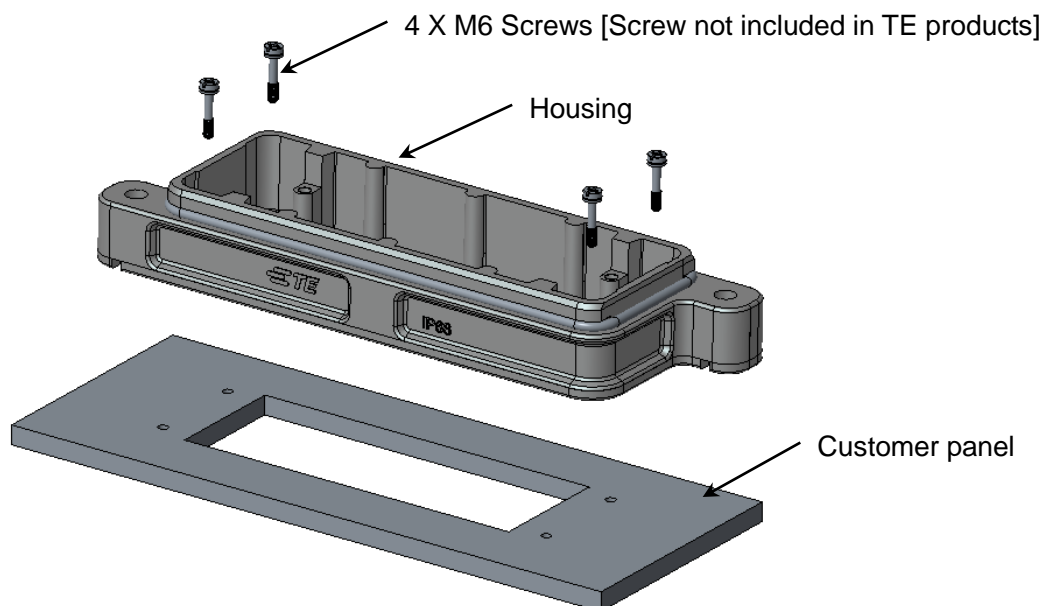

Figure: 20

For surface mounting locking

- HXXBPR-SGRHC-PG/M

Fix housing with 4 x M5 screws. Tightening torque refer to spec of screws, but no less than 3Nm

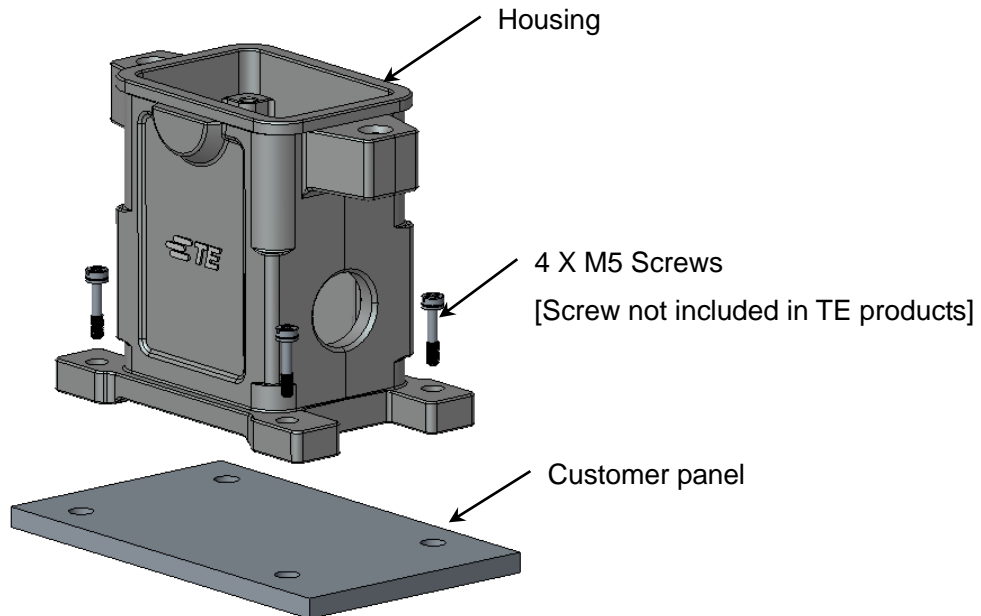

Figure: 21

- HXXBPR-SGRH-PG/M

Fix housing with 4 x M8 screws. Tightening torque refer to spec of screws, but no less than 5Nm

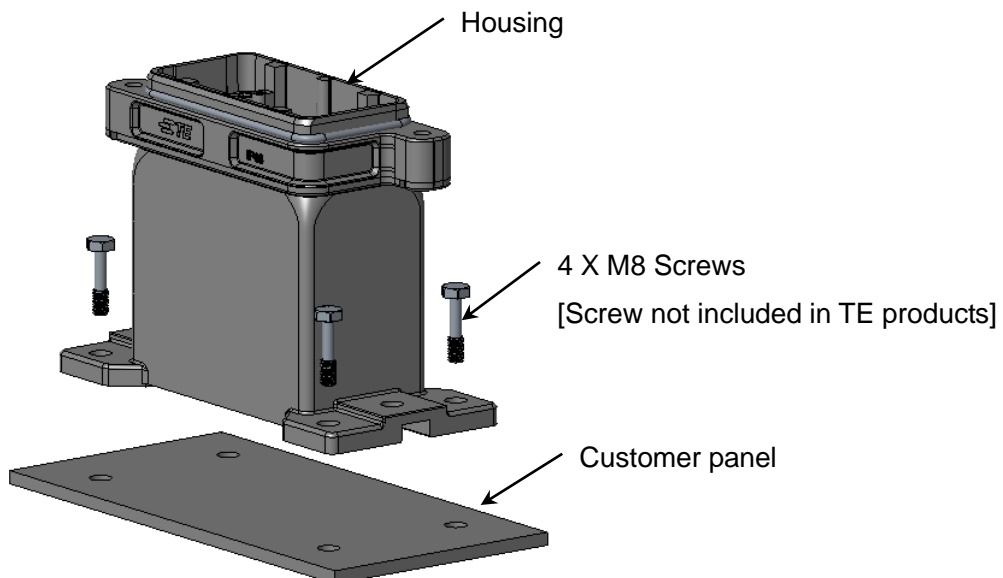

Figure: 22



- HXXBPR-AGCT

Fix housing with 4 x M6 screws. Tightening torque refer to spec of screws, but no less than 4Nm

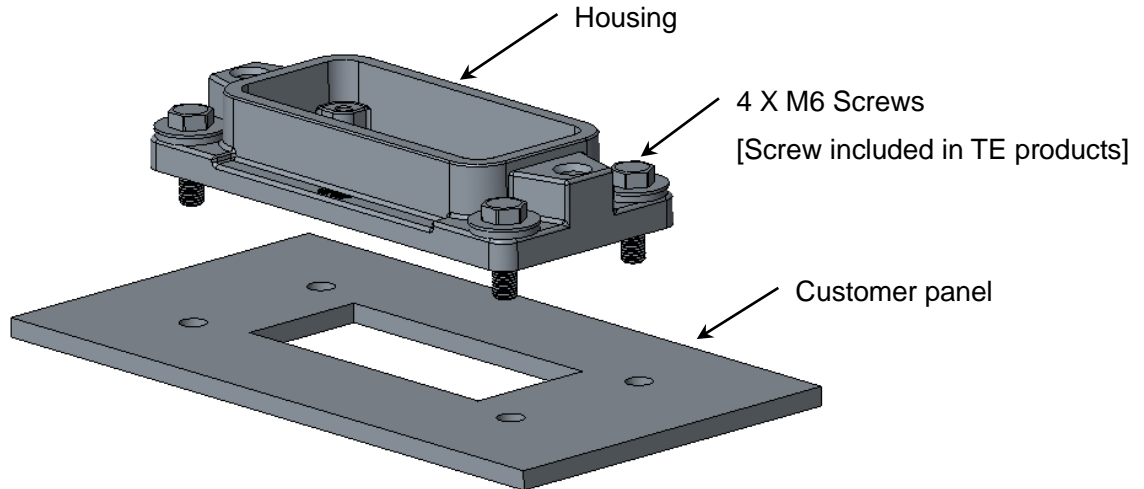

Figure: 23

- Assembly female insert into housing

Fix female insert with 4 x M3 screws. Tightening torque refer to spec of female insert.

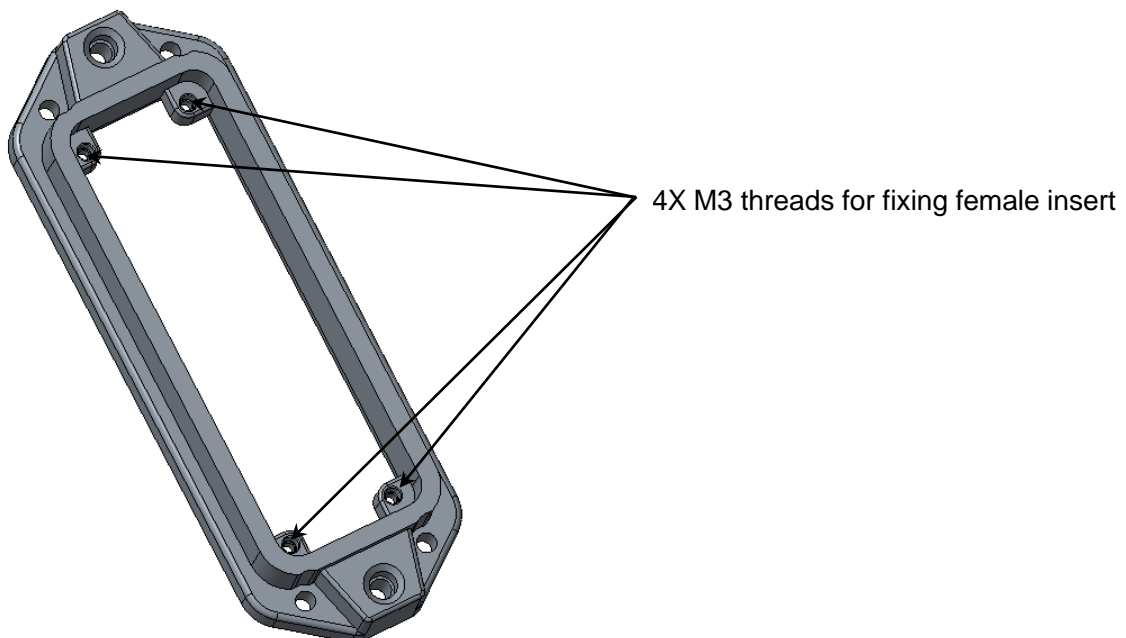

Figure: 24

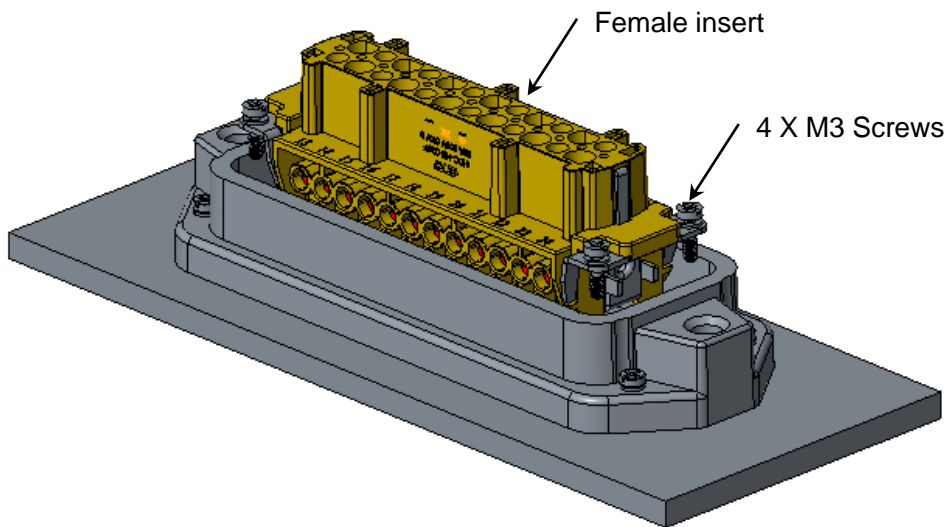

Figure: 25

Note:

- Refer application spec of female insert separately and before fixing to housing, it should be well prepared.
- Whatever the type of housing or the type of female insert, they have same assembly process here.

➤ Assembly male insert into hood

Fix female insert with 4 x M3 screws. Tightening torque refer to spec of male insert.

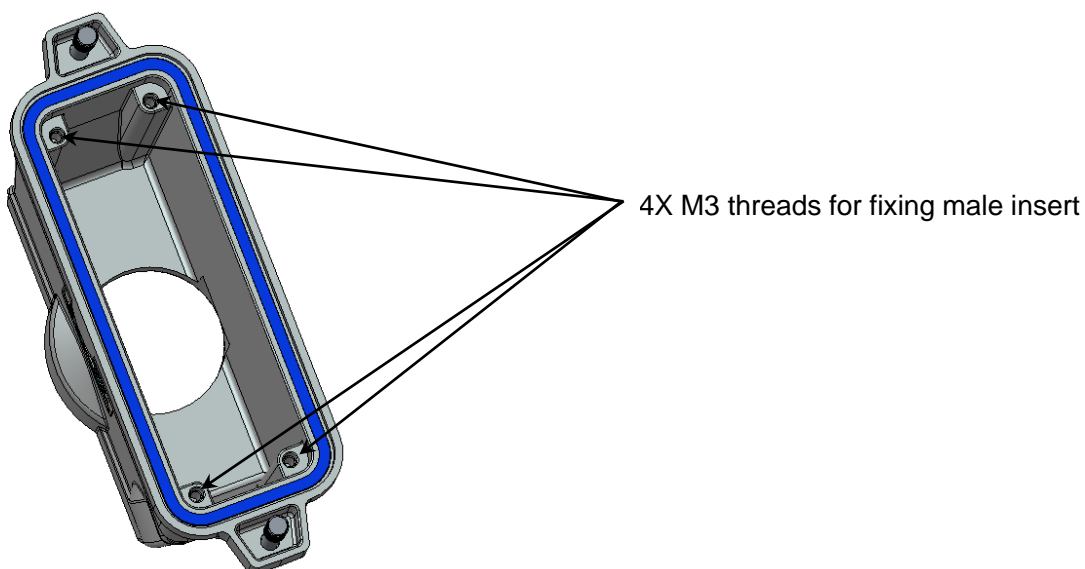

Figure: 26

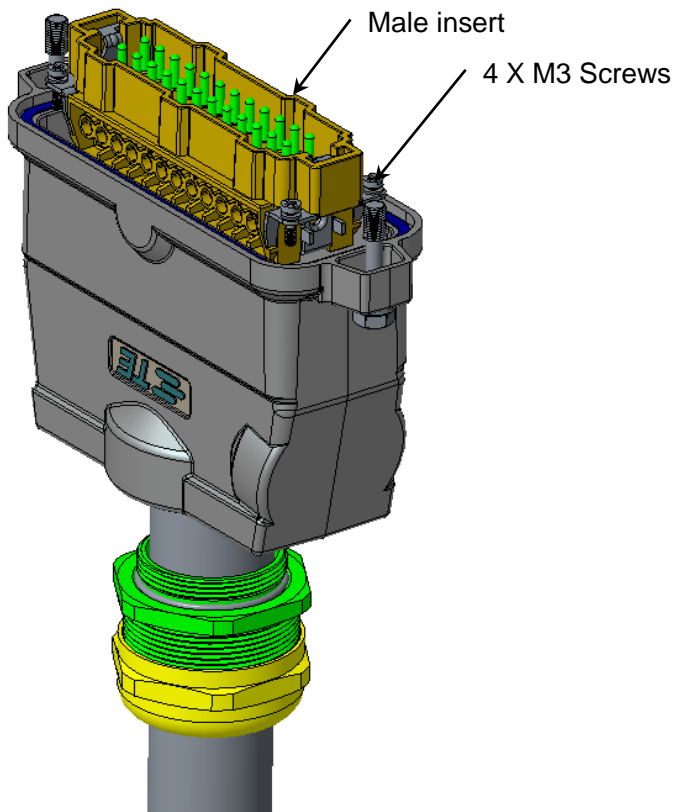

Figure: 27

Note:

- Refer application spec of male insert separately and before fixing to hood, male insert should be well prepared.
  - Whatever the type of hood or the type of male insert, they have same assembly process here.
- Assembly cable gland with hood  
Fix cable gland to hood. Tightening torque refer to spec of cable gland.

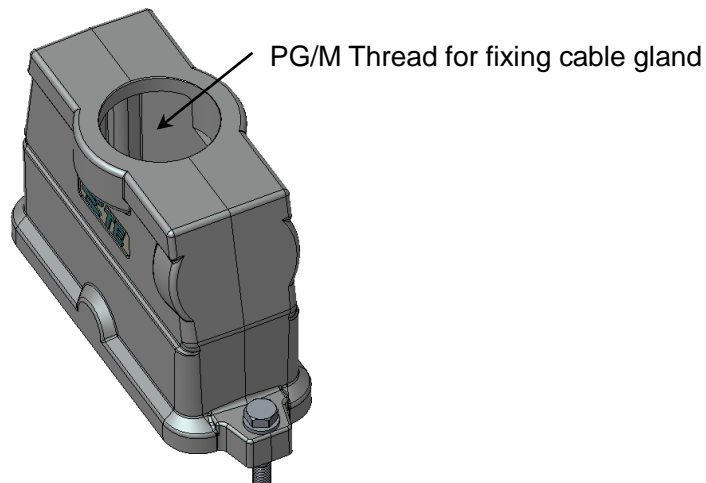

Figure: 28

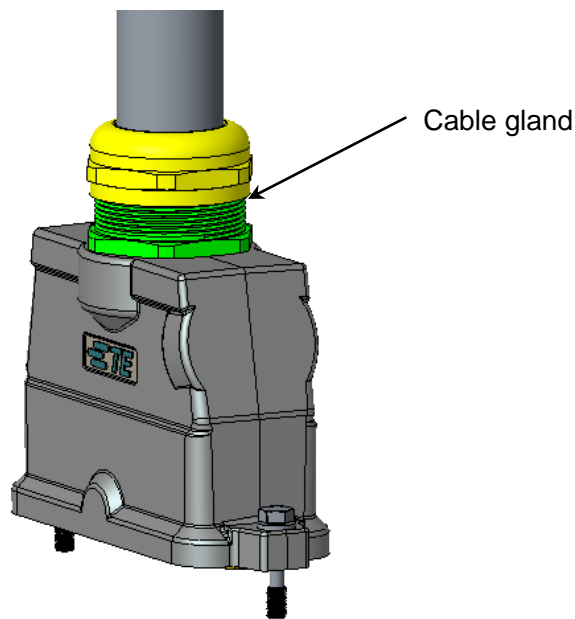

Figure: 29

Note:

- Refer application spec of cable gland separately.
- Whatever the type of hood or the type & size of thread hole, they have same assembly process here.

➤ Assembly hood with housing

Fix hood to housing with 2 x M6 screws. Tightening torque 4Nm

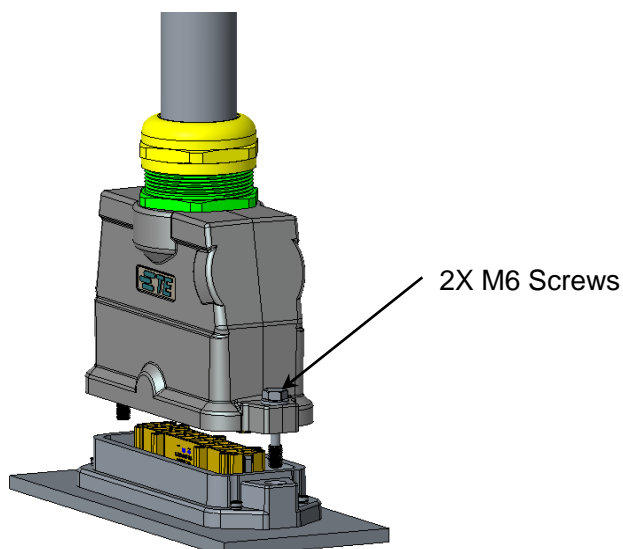

Figure: 30

Note:

- Whatever the type of hood & housing, they have same assembly process here.

## 6. STORAGE

The connectors should be stored in the air ventilation, no corrosive gas, no rain and no snow in the warehouse. Relative humidity: less than 85% RH.



Any conflict is found between this file and customer drawings, customer drawings are preferential.  
And please contact TE Connectivity related engineer if necessary.

----- End-----