

ECU 36POS.&48POS. CONNECTOR

Contents/目录

<b>1</b>	<b>GENERAL</b> .....	<b>3</b>
<b>1</b>	<b>综述</b> .....	<b>3</b>
1.1	Purpose .....	3
1.1	目的 .....	3
1.2	Customer Drawing/ Documents.....	3
1.2	客户图纸/文档 .....	3
<b>2</b>	<b>Product Description</b> .....	<b>3</b>
<b>2</b>	<b>产品说明</b> .....	<b>3</b>
2.1	36Pos plug connector.....	3
2.1	36 位母端连接器 .....	3
2.2	48Pos plug connector.....	4
2.2	48 位母端连接器 .....	4
<b>3</b>	<b>36POS.&amp;48POS. CONNECTOR ASSEMBLY</b> .....	<b>5</b>
<b>3</b>	<b>36 位和 48 位连接器组装</b> .....	<b>5</b>
3.1	Lever Assemble .....	5
3.1	操作杆装入 .....	5
3.2	Terminal Insertion.....	5
3.2	端子插入 .....	5
3.2.1	Insertion MCON1.2 CB terminal.....	5
3.2.1	MCON1.2 端子的插入 .....	5
3.2.2	Sealing plug type .....	6
3.2.2	盲堵类型 .....	6
3.3	Retainer(TPA) Assembly .....	7
3.3	二次锁 (TPA) 插入到位 .....	7
3.4	Cover Assembly.....	8
3.4	盖子装入 .....	8
3.5	Fixing cable on the cover.....	10
3.5	线束绑定 .....	10
3.6	Mating plug with interface/header .....	10
3.6	连接对配端/ECU 控制单元 .....	10
<b>4</b>	<b>36POS.&amp;48POS. CONNECTOR DISASSEMBLY</b> .....	<b>12</b>
<b>4</b>	<b>36 位和 48 位连接器拆装</b> .....	<b>12</b>
4.1	Unmating of the plug from interface/header.....	12
4.1	从对配端拆离连接器 .....	12
4.2	Release cable from COVER .....	13
4.2	将绑线拆除 .....	13
4.3	Release COVER from housing.....	13
4.3	将盖子退出 .....	13

---

4.4 Release Retainer (TPA) from final lock to open .....	14
4.4 将二次锁 (TPA) 退出 .....	14
4.5 Terminals Extract .....	14
4.5 端子退出 .....	14
<b>5 Appendix.....</b>	<b>15</b>
<b>5 附页.....</b>	<b>15</b>

## 1 GENERAL

### 1 综述

#### 1.1 Purpose

#### 1.1 目的

This application specification includes the guidelines to be followed during assembly, installation and disassembly of the ECU 36Pos. and 48Pos. Plug housing.

本规范用于指导 36P(MCON1.2 CB)及 48P(MCON1.2 CB) ECU 线束连接器的组装,安装和拆卸。

#### 1.2 Customer Drawing/ Documents

#### 1.2 客户图纸/文档

This application specification is based on the latest valid customer drawings.

本规范基于以下有效客户图纸的最新版本。

This application specification is based on the latest customer drawings/Documents.

产品尺寸、材料和表面

C-2316374	36Pos.&48Pos. MCON1.2 CB REC. HSG. ASSY
1928S00234_01	BOSCH INTERFACE DRAWING
1928S00240_01	BOSCH INTERFACE DRAWING
108-32589	36Pos.&48Pos. Product Specification

The document is also a reference for the application

以下文档作为此应用规范的参考文件

114-18464 MCON1.2 Application Spec (MCON1.2 CB端子压接规范)

The release tool as below PN. However, it can be replaced by similar tool

以下是端子退出工具, 类似结构的退出工具经验证也可作为替代工具

2-1579008-1 MCON1.2 Extraction Tool (MCON1.2 CB端子退出工具)

## 2 Product Description

### 2 产品说明

The 36P/48P plug type connector system are used for the connection of Engine Control Units inside the vehicle.

36P/48P 母端连接器系统用于连接车辆的引擎控制单元的信号及电流传输

#### 2.1 36Pos plug connector

#### 2.1 36 位母端连接器

The plug connector contains below parts. 母端连接器包含以下零件。

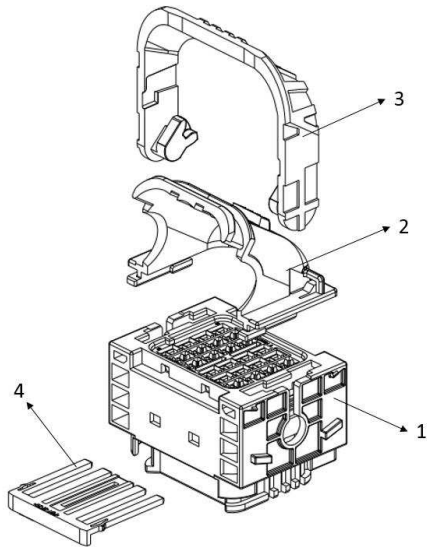

36P HOUSING ASSY  
36P 塑壳本体

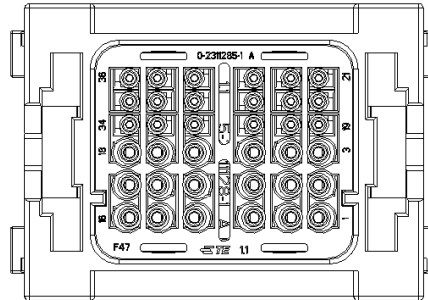

ASSY 36P connector contains below part.  
36P 连接器组装件由以下部分组成。

1. 36P HOUSING ASSY  
36P 塑壳本体
2. COVER  
盖子
3. Lever  
操作杆
4. Retainer(TPA)  
端子二次锁

## 2.2 48Pos plug connector

### 2.2 48 位母端连接器

ASSY 48P connector contains below part.  
48P 连接器组装件由以下部分组成。

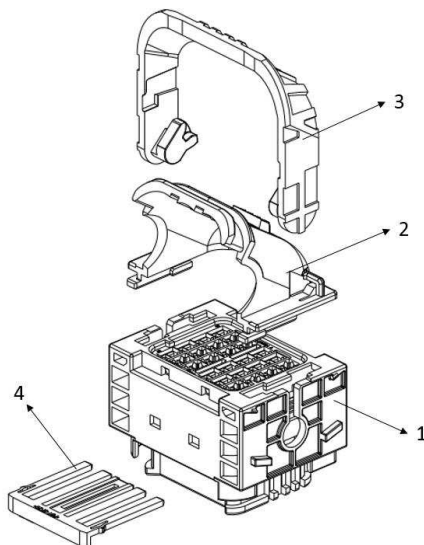

48P HOUSING ASSY  
48P 塑壳本体

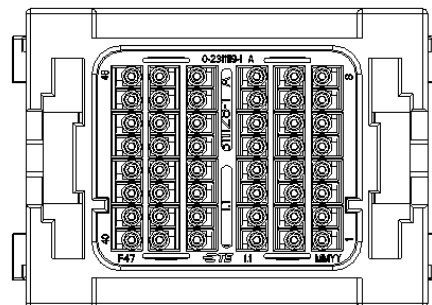

1. 48P HOUSING ASSY  
48P 塑壳本体
2. COVER  
盖子
3. Lever  
操作杆
4. Retainer (TPA)  
端子二次锁

### 3 36POS&48POS. CONNECTOR ASSEMBLY

#### 3 36 位和 48 位连接器组装

##### 3.1 Lever assembly

##### 3.1 操作杆装入

The Lever is assembled in harness maker side, it can be assembled in both side, the assy side decide the wire out direction, it is due to OEM customer's request.

操作杆在线束厂端来组装，它可以朝两个来装配，但是装配的朝向决定了线束端出线的方向，这个线束出线的方向取决于 OEM 客户的需求。

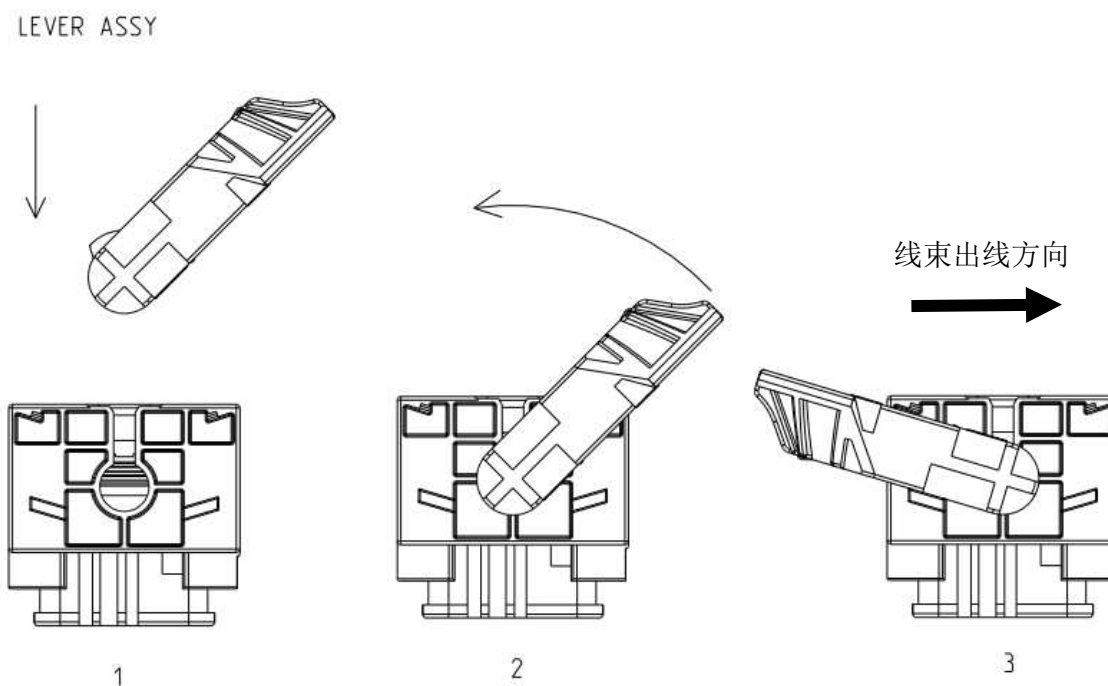

##### 3.2 Terminal insertion

##### 3.2 端子插入

The contact cavities are polarized to prevent the contacts from being inserted upside-down.  
端子与塑壳孔都有方向性来防止端子不正确的插入。

##### 3.2.1 Insertion MCON1.2 CB terminal

##### 3.2.1 MCON1.2 CB 端子的插入

A. Insert the terminal (as below direction) as far as the end of the spring engages and produces an audible click. Complete locking can be examined by gently pulling back the terminal.

A. 按照如下方向插入端子，插入到位后有轻微咔嗒声。为确保插入到位，可轻微回拉线材检查。

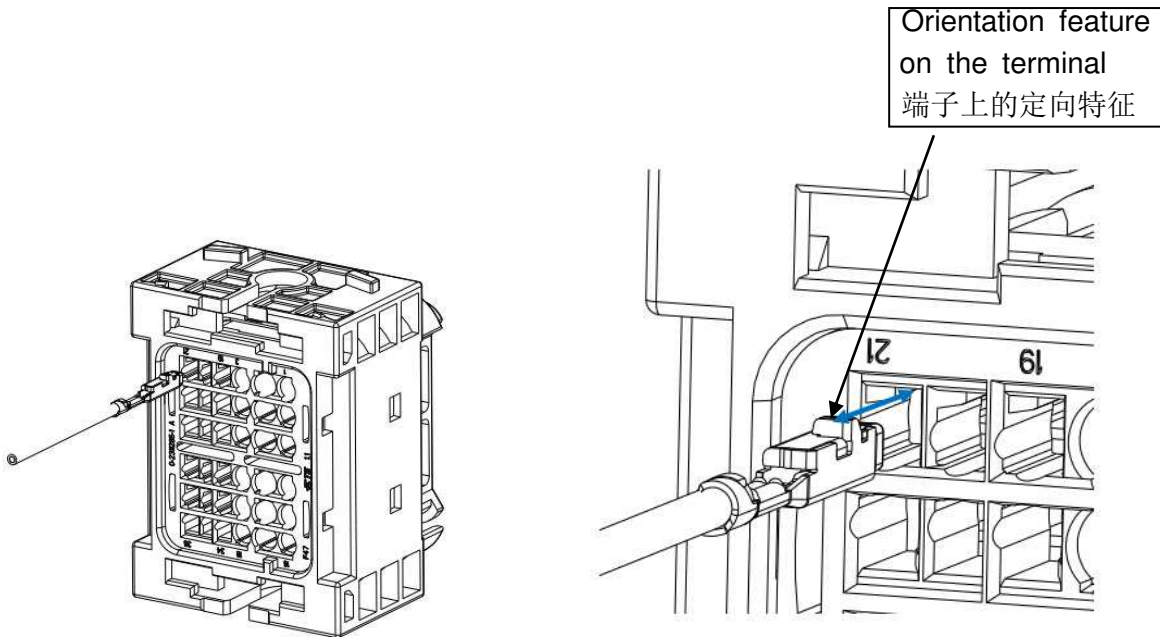

B. Wire size for contact cavity requirement according to TE customer drawing C-2316374

B. 对应孔位使用的线径要求参考泰科客户图纸 C-2316374

C. If 1.0mm<sup>2</sup> wire need to be application for small hole (0.35-0.75 mm<sup>2</sup> defined in C-Drawing), special crimping requirements are needed for wire insulation area. After crimping, insulation crimping width=1.95mm max., insulation crimping height=2.35mm max. Other crimping areas should follow the related contact crimping specification application.

TE related tool no. is Anvil: 6-1803512-2, Ins crimper: 7-1803248-8, Wire crimper: 1803126-2, refer to appendix special instruction sheet (last page), also can contact TE sales for detail

Be note, the quantity of cavities for this special application should be less than half of total cavities to avoid terminal insertion difficult.

C. 如果用 1.0mm<sup>2</sup> 线径的线适配到 36/48P 产品中的小孔中 (C 图定义 0.35-0.75 mm<sup>2</sup>)，那么绝缘皮区域需要特殊的卡模来压接。压接要求，绝缘皮压接宽度 1.95mm max.，压接高度 2.35mm max.，其他区域的压接要求参考相关端子的压接规范。

泰科相关卡模刀片料号 6-1803512-2, 7-1803248-8, 1803126-2, 参考最后一页特殊应用说明，详情请咨询泰科相关销售。

注意，这种特殊的应用的孔位建议不要超过总孔位的一半，可以避免后插的端子难插入的问题。

### 3.2.2 Sealing Plug 类型

#### 3.2.2 盲堵类型

A. When all the contact cavity are fully equipped by terminal, it is not need sealing plug

A. 当所有的端子孔都插满端子，不需要额外的盲堵

B. When all the contact cavity aren't fully equipped by terminal, it is need sealing plug, suggested sealing plug as below, P/N 2286476-1 suitable for wire size 0.35~0.75mm<sup>2</sup>(insulation  $\phi$ 1.2mm~ $\phi$ 1.9mm), P/N 2286476-2 suitable for wire size 0.75~1.5mm<sup>2</sup>(insulation  $\phi$ 1.2mm~ $\phi$ 1.9mm)

B. 当端子孔插不满端子时，需要用额外的盲堵，如下图示意，料号 2286476-1 适用线径 0.35~0.75mm<sup>2</sup> (绝缘皮直径  $\phi$ 1.2mm~ $\phi$ 1.9mm)，料号 2286476-2 适用线径 0.75~1.5mm<sup>2</sup> (绝

缘皮直径  $\phi 1.9\text{mm} \sim \phi 2.4\text{mm}$ )

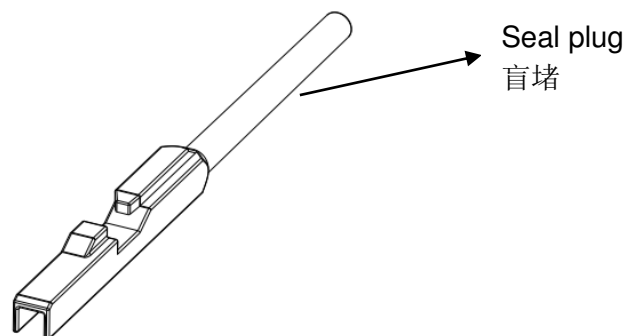

### 3.3 Locking Secondary Lock Plate

#### 3.3 二次锁 (TPA) 插入到位

After all the terminal and sealing plug assemble in the housing, then assemble retainer(TPA), follow picture below, push to the end to the right position.

当所有端子、二次锁都装入塑壳中后，延如下图方向装入二次锁，当二次锁推到底后，二次锁装入到正确的位置

If the retainer (TPA) does not fully close, move it to the OPEN position, ensure that all contacts are fully seated, then try again. **DO NOT force the TPA to close.**

如果二次锁 (TPA) 无法组装到位，请将二次锁 (TPA) 退到预锁位置，确认每个端子都挺入到位后再次锁二次锁 (TPA)。

切不可在端子未插入到位时强行锁上二次锁 (TPA)。

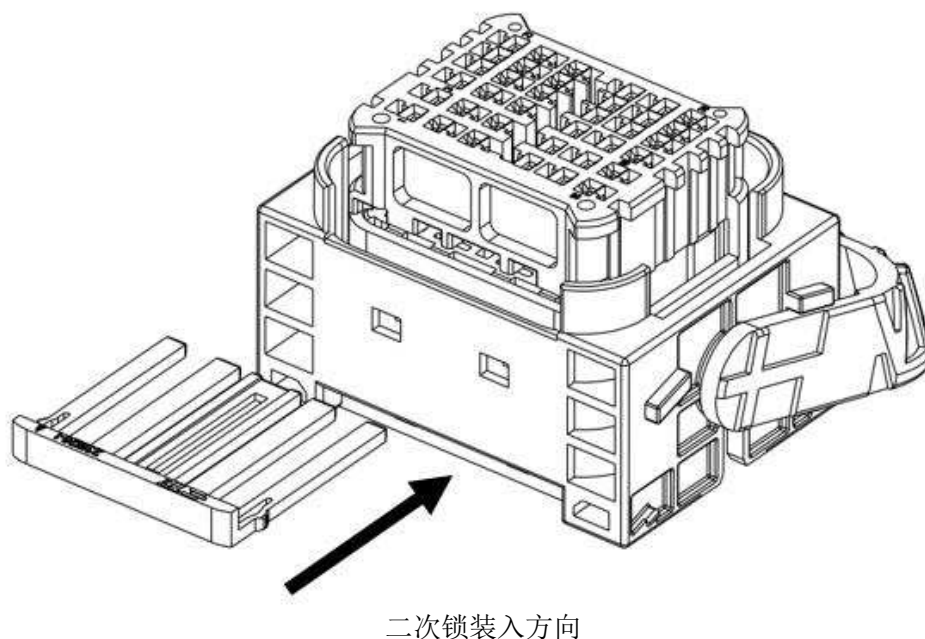

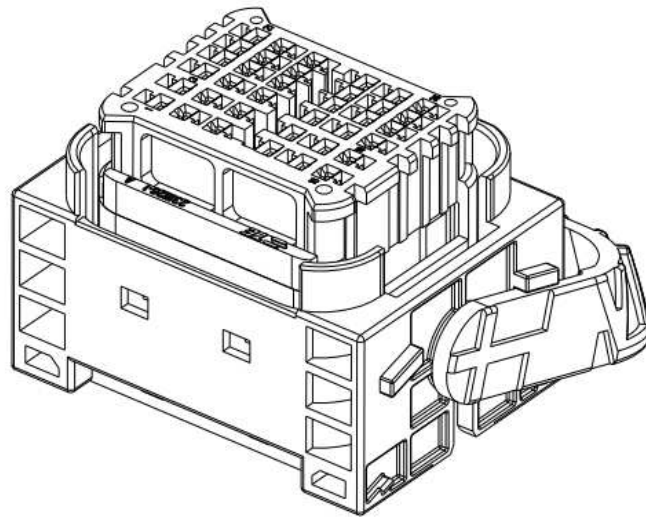

二次锁装入到锁死位置

### 3.4 Cover assemble

#### 3.4 盖子装入

Step1. Put cover to the right position according to housing, the wire out direction should be same as lever, then lever can have a rotation(as below picture showed);

第一步，首先盖子的出线方向要符合 lever 出线方向的要求，这样装配后 lever 可以转动（如下示意）

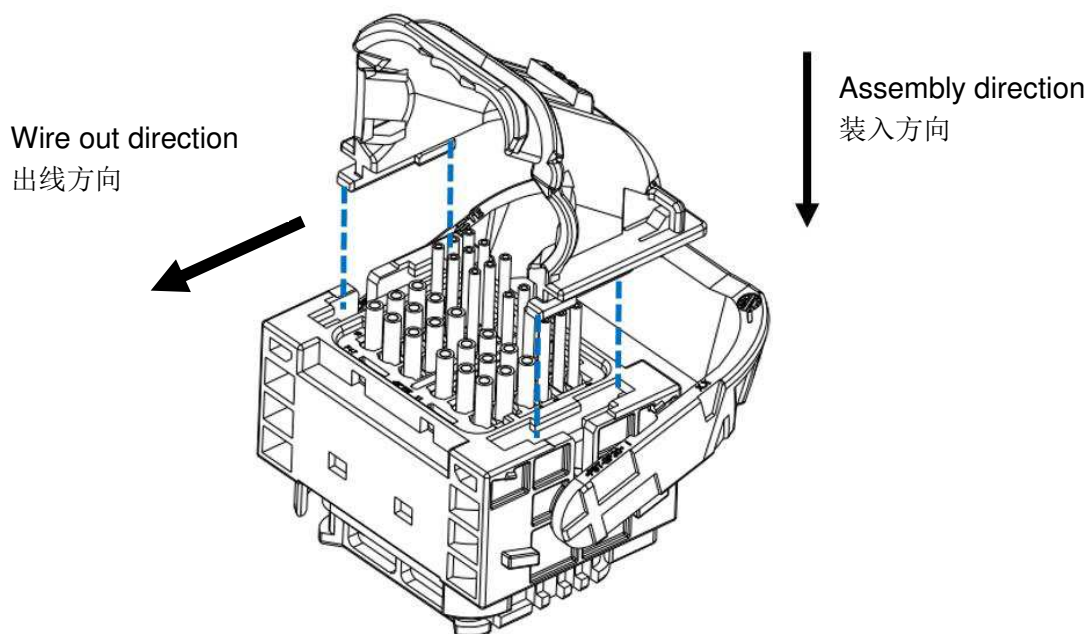

Step2. Assemble cover to the suitable position to the housing, related rib should mating with each other (下图示意).

第二步，将盖子同塑壳对应的筋位配合装入，如下图示意



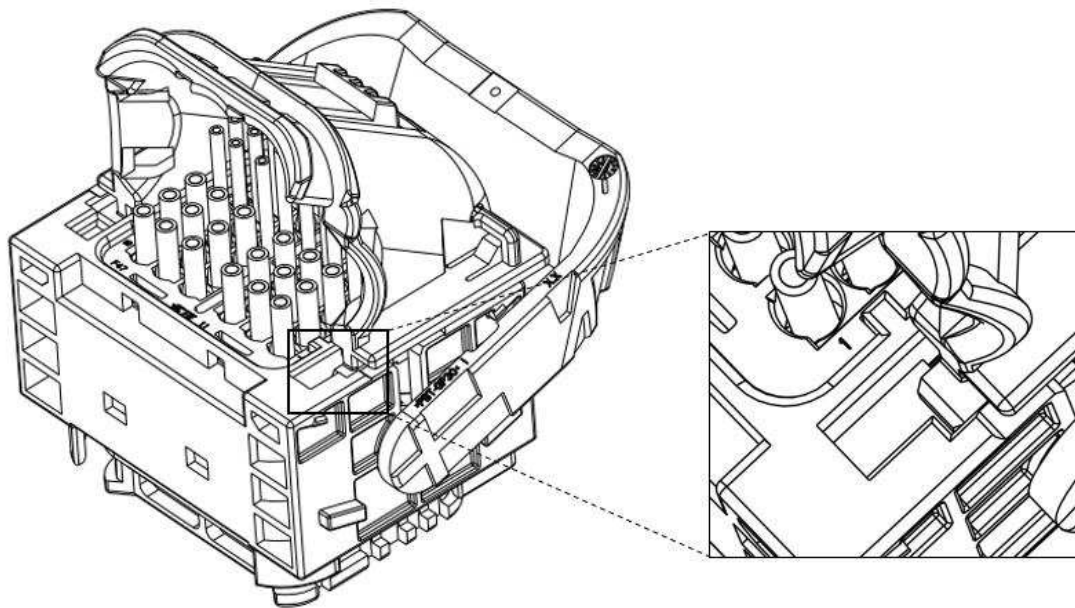

Step3. Push the cover from right to left, you can hear some locking noise during the push process, then it is in the end position, you can't push it anymore(showed below) .

第三步，从右向左来推盖子，在推的过程中能听到轻微的“哒”声，说明盖子已经装到最终位置，如下图示意

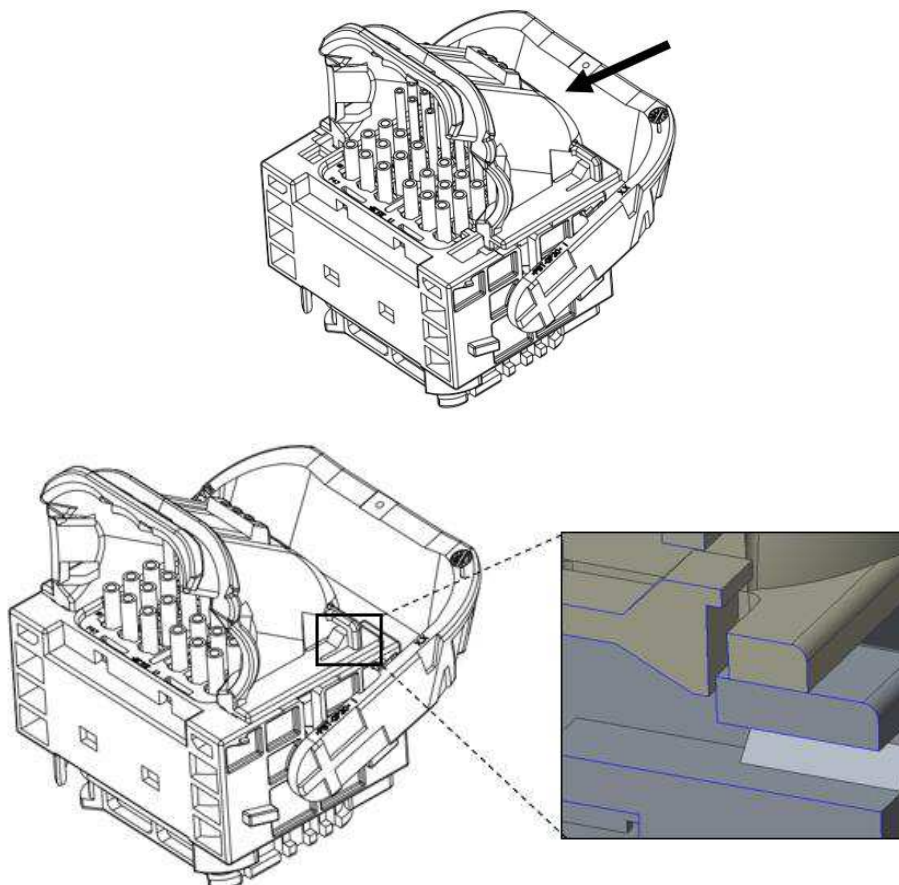

### 3.5 Fixing cable on the cover

#### 3.5 线束绑定

Choose the suitable ribbon to fix the cable

选择合适的扎带来固定线束



### 3.6 Mating plug with interface/header

#### 3.6 连接对配端/ECU 控制单元

Different coding mate with different header pocket.

不同 CODE 的产品对配不同 CODE 的框口界面

Below are the coding information of interface pocket, detail refer to Bosch drawing 1928S00234\_01 and 1928S00240\_01

下面是 CODE 界面相关信息，详细可以参考博世图面 1928S00234\_01 和 1928S00240\_01

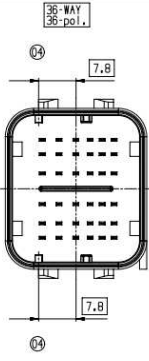
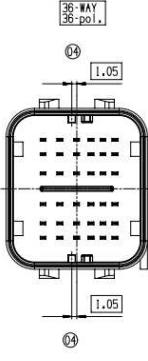
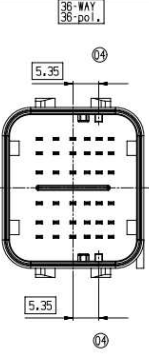
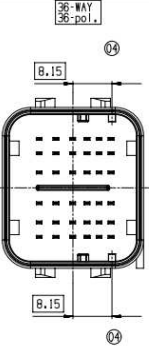
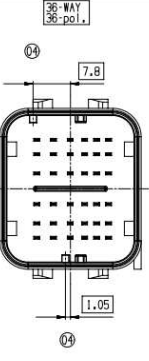
A	B	C	D	E
				
1 928 500 234-01	1 928 500 235-01	1 928 500 236-01	1 928 500 237-01	1 928 500 238-01

F	G	H	I	Z
I 928 500 240-01	I 928 500 241-01	I 928 500 242-01	I 928 500 243-01	I 928 500 244-01

Related Plug coding information refer to TE Customer drawing C-2316374.  
相关线束端连接器 CODE 信息参考泰科客户图纸 C-2316374.

### 36POS. CODING VARIANT

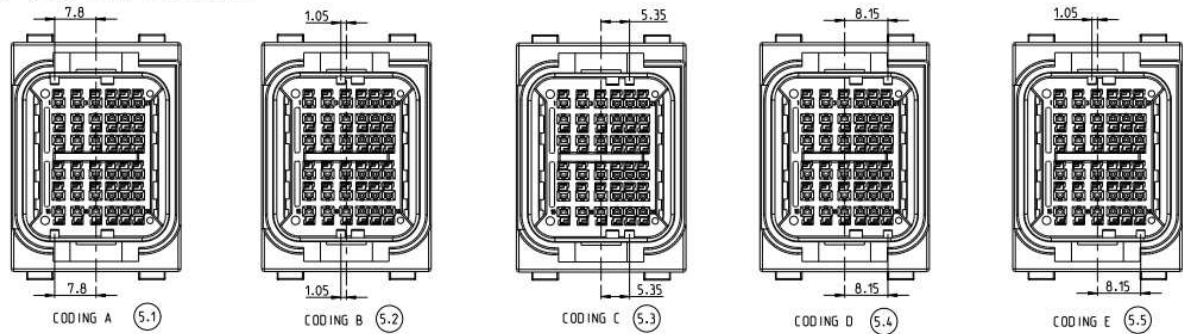

### 48POS. CODING VARIANT

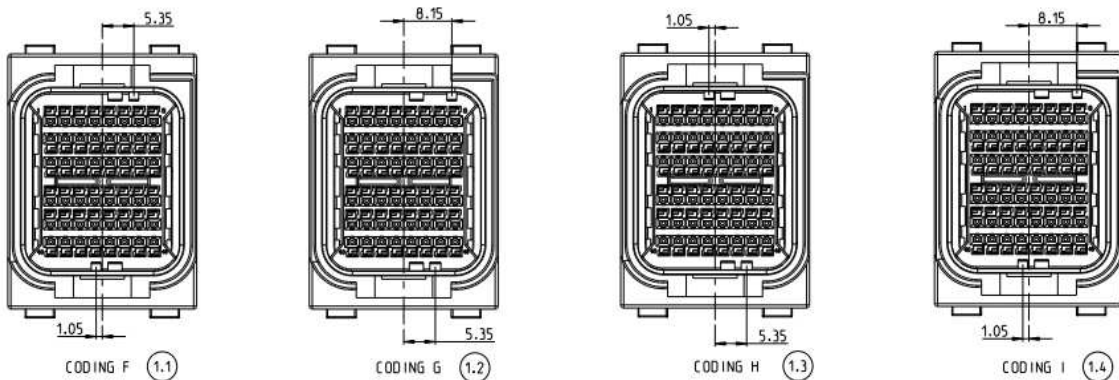

Assemble the plug housing(36Pos. and 48Pos.) to ECU from left to right one by one, the sequence shouldn't be changed, otherwise it can't be assembled completely.

按照从左向右的顺序依次按照线束到 ECU 单元，注意顺序不要变更，否则无法装配完整。

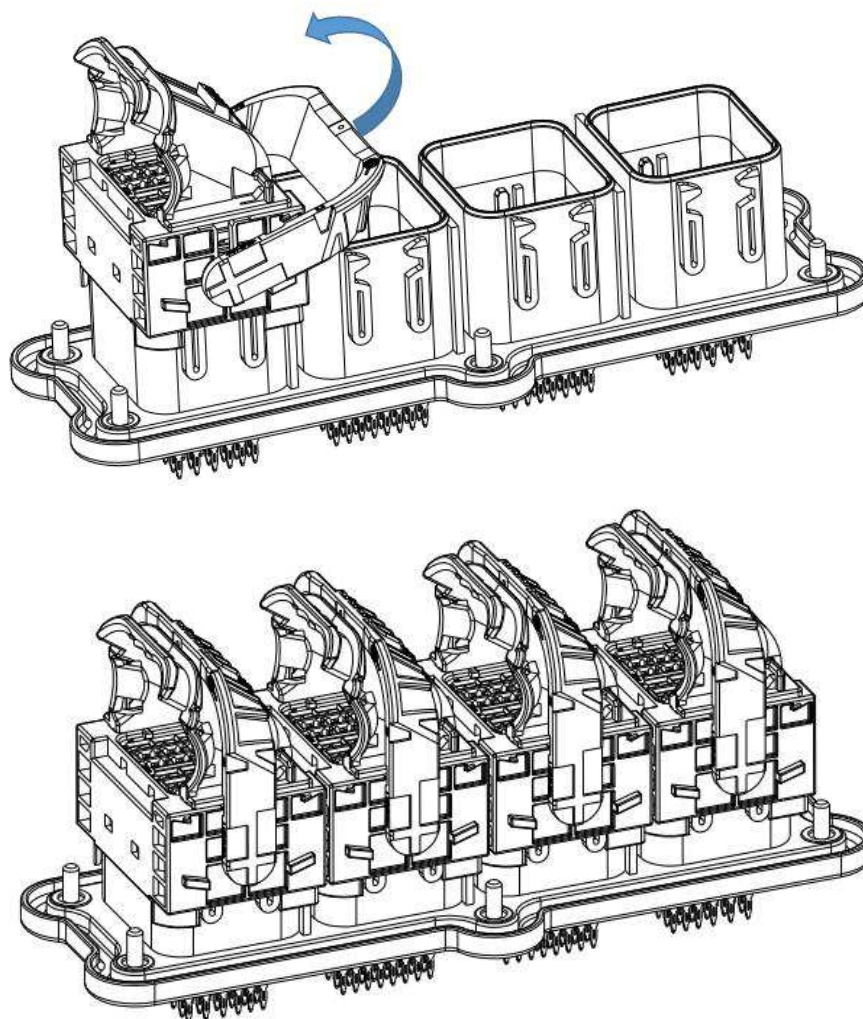

## 4 36POS&48POS CONNECTOR DISASSEMBLY

### 4 36 位及 48 位连接器拆装

#### 4.1 Unmating of the plug from interface/header

##### 4.1 从对配端拆离连接器

4.1.1 Press the locking latch to the end

4.1.1 将锁扣按压到底

4.1.2 Operate the lever to open position

4.1.2 转动操作杆将连接器打开

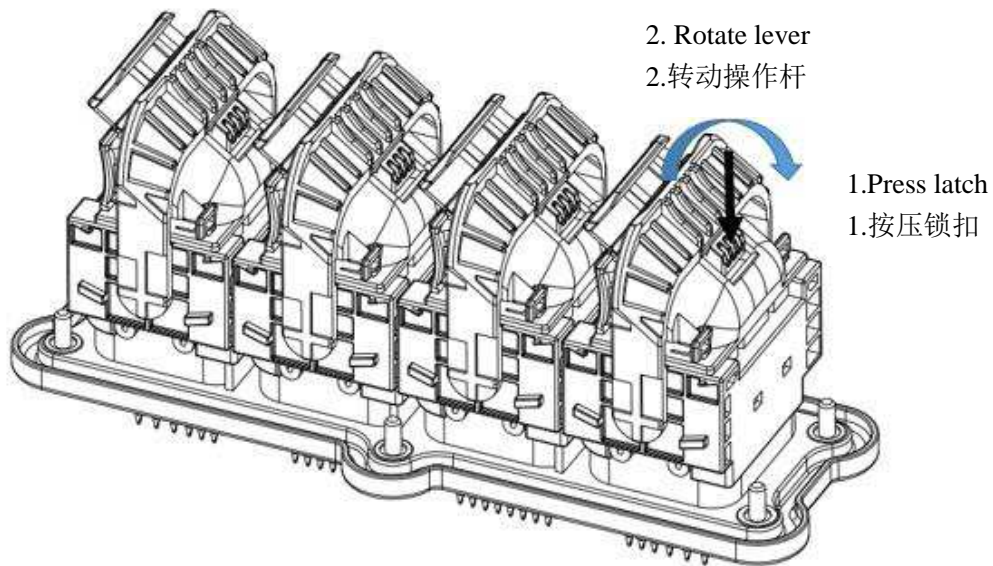

4.1.2 Take care the unmatting sequence, the sequence should be opposite to the mating process, from right to left one by one to operate.

4.1.2 注意连接器的打开顺序，打开顺序同安装顺序刚好相反，如上图示意，从右向左一次打开

#### 4.2 release cable from wire dress (optional)

#### 4.2 将绑线拆除 (可选)

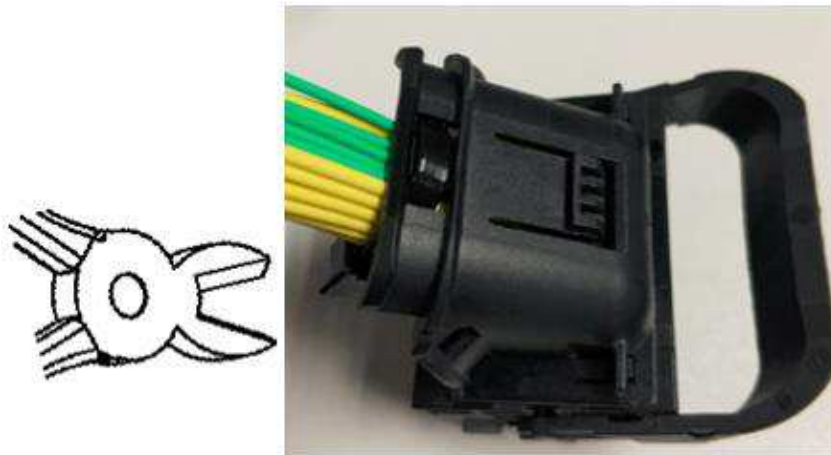

#### 4.3 Release cover from housing

#### 4.3 将盖子退出

Use tool to raise the locking latch of cover, when the latch released then push the cover back, these actions should be operated at both side. (refer as below picture)

在盖子的两侧利用工具将盖子上的锁扣翘起，然后向后推盖子，将盖子退出

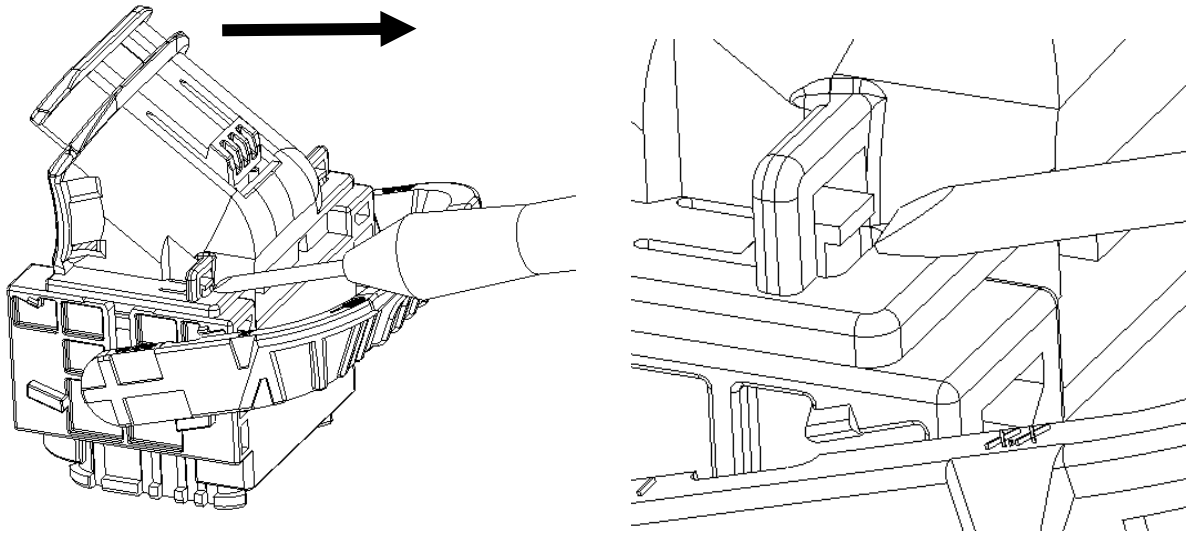

#### 4.4 Release retainer (TPA) from final lock to open

#### 4.4 将二次锁（TPA）退出

Use tool to move retainer (TPA) to open position (refer as below)

利用工具将二次锁（TPA）翘出塑壳

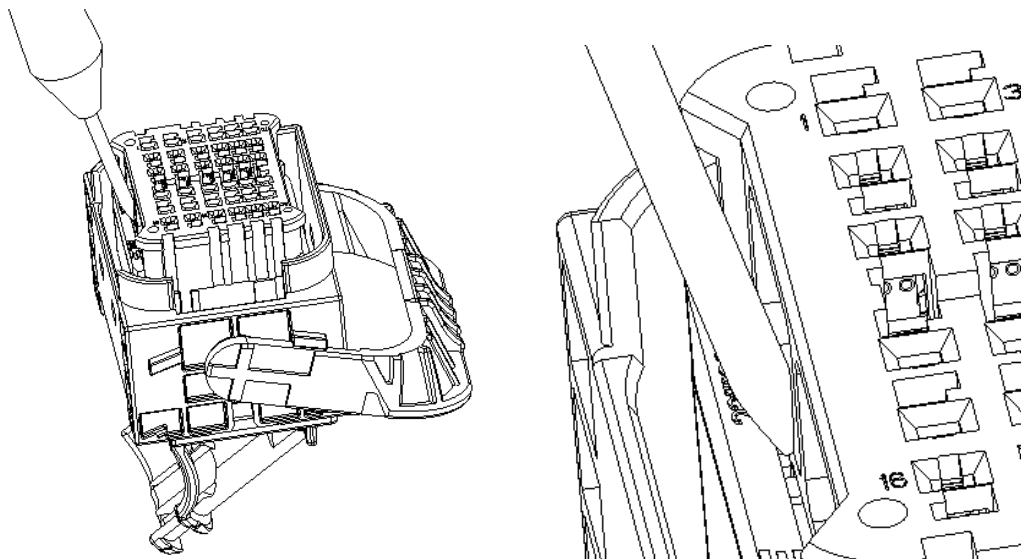

#### 4.5 Terminals Extract

#### 4.5 端子退出

Use terminal extraction tool, TE part no. 2-1579008-1, push the tool to the end of cavity and meanwhile pull the wire out. (Refer as below picture)

利用退 pin 工具退端子，泰科料号 2-1579008-1，将退 pin 工具插到底同时拉对应端子的线材，将端子退出塑胶（参考如下示意图）

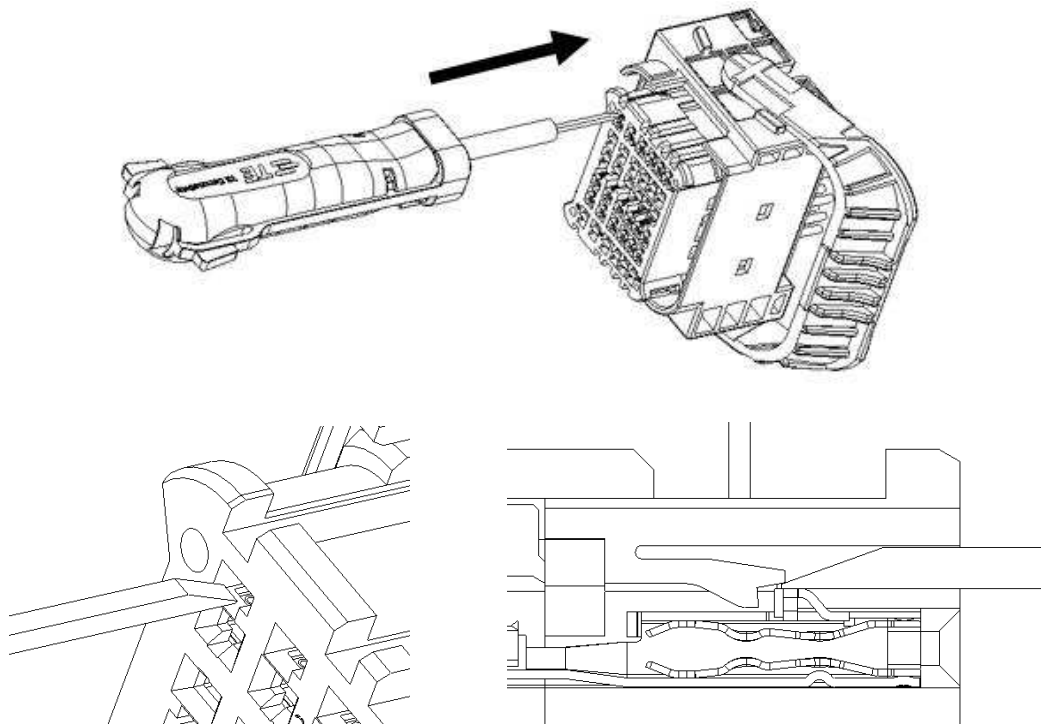

**5 Appendix Special Instruction Sheet**  
5 附页特殊应用说明

## MCON 端子 1452503 特殊压接结构说明

### 1 综述

本规范定义了端子 1452503-1 应用于小孔径塑壳 1.0mm<sup>2</sup>线的特殊压接（应用请参考 TE 图纸 C2316374）。

备注：本规范中压接参数仅适用于 TE 压接工具，本规范所涉及外的情况均由客户自行制定。

### 2 参考文件

#### 2.1 TE 图纸

C1534326	MCON 1.2 CB (CLEAN BODY)
C2316374	36/48 POS MCON1.2 CB REC. HSG.ASSY. SEALED (Note 2)

#### 2.2 应用规范

114-18022
114-101085

### 3 量测

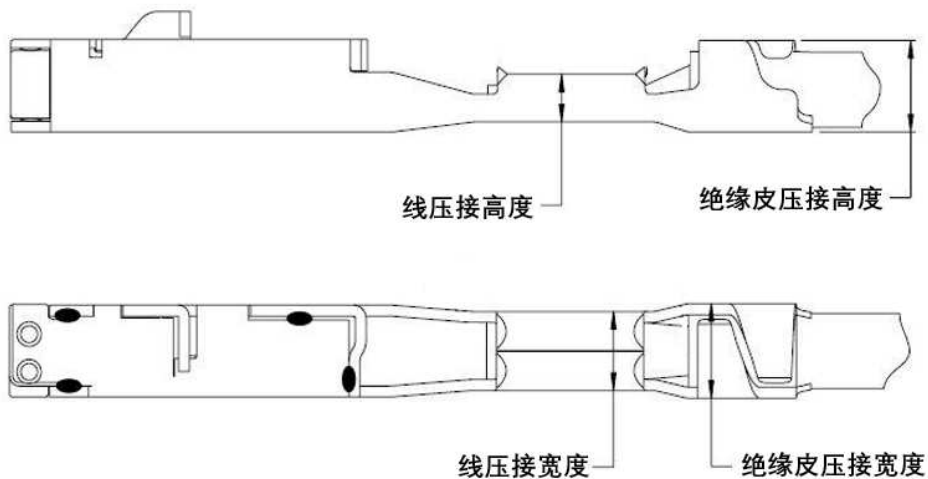

### 4 尺寸要求

压接端子外形及尺寸公差

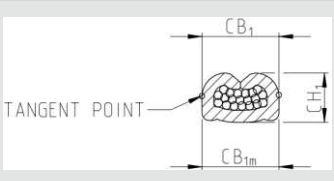
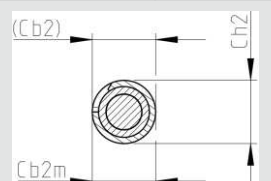
端子料号	线径	线类型	线压接		绝缘皮压接		备注
			压接高度	压接宽度	压接高度	压接宽度	
1452503-1	1.0mm <sup>2</sup>	FLR	1.18+/-0.05	(1.78)	2.35 Max.	1.95 Max.	TE压接刀片号： 6-1803512-2， 7-1803248-8， 1803126-2， 任何问题，请 联系贵司对应 TE销售工程师
			 <p>压接截面参考</p>		 <p>压接截面参考</p>		



# MCON 1452503 Crimping Specification for Special Application

## 1 SCOPE

This specification contains the guideline for 1452503-1 used on small size housing with 1.0mm<sup>2</sup> special crimping (Application please refer to TE drawing C2316374).

Remark: this specification defines crimping parameter only fit for TE applicator, any out of this applicator situation customer can define crimping by themselves.

## 2 REFERENCE DOCUMENTS

### 2.1 TE Drawing

- C1534326 MCON 1.2 CB (CLEAN BODY)
- C2316374 36/48 POS MONO1.2 CB REC. HSG.ASSY. SEALED (Note 2)

### 2.2 APPLICATION SPECIFICATIONS

- 114-18022
- 114-101085

## 3 MEASUREMENT

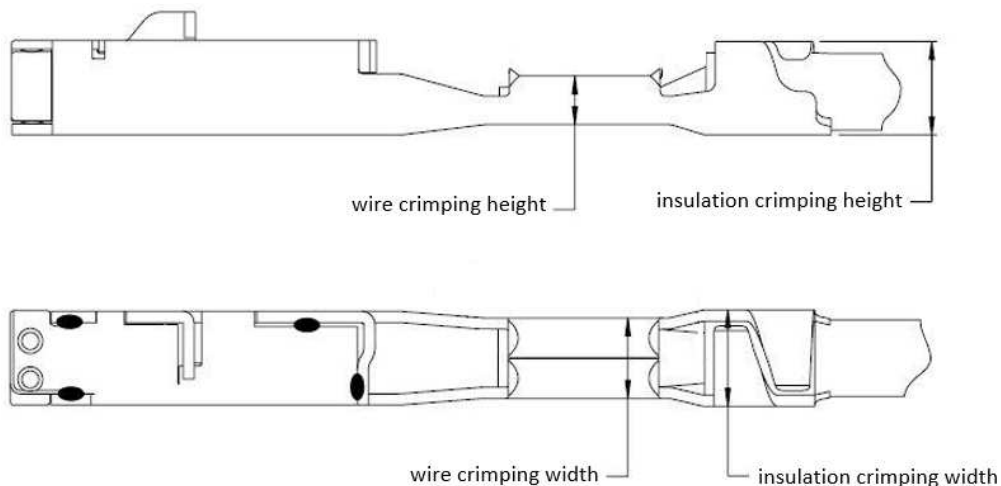

## 4 DIMENSIONS

### Crimping parameter

Part No.	Wire Size	Wire Type	Wire crimping		Insulation crimping		Remark
			Crimping Height	Crimping Width	Crimping Height	Crimping Width	
1452503-1	1.0mm <sup>2</sup>	FLR	1.18+/-0.05	-1.78	2.35 max	1.95max	TE Crimping die set: 6-1803512-2, 7-1803248-8, 1803126-2 <b>Any question please contact TE sales</b>
			