

Product Specification

108-60043

CHAMP .050 Series (II) Connector Wire to Board Type

1. Scope:

1.1 Contents

This specification covers the requirements for product performance, test methods and quality assurance provisions of CHAMP .05. Series (II) Connector (Wire To Board Type)

The applicable product descriptions and part numbers are as shown in Fig. 1:

2. Applicable Documents:

The following documents form a part of this specification to the extent specified here in. In the event of conflict between the requirements of this specification and the product drawing, the product drawing shall take precedence. In the event of conflict between the requirements of this specification and the referenced documents, this specification shall take precedence.

2.1 AMP Specifications:

- A. 109-5000 Test Specification, General Requirements for Test Methods
- B. 114-5136, 5124 Application Specification
- C. 501-60015 Test Report

2.2 Military Standard and Specifications:

- MIL-STD-202 Test Methods for Electronic and Electrical Component Parts

THIS INFORMATION IS CONFIDENTIAL AND IS DISCLOSED TO YOU ON CONDITION THAT NO FURTHER DISCLOSURE IS MADE BY YOU TO OTHER THAN AMP PERSONNEL WITHOUT WRITTEN AUTHORIZATION FROM AMP SHANGHAI LTD

	O	RELEASED FB00-0268-04	C.W	20AUG	DR	C. WANG	tyco Electronics	Tyco Electronics AMP Shanghai Ltd	
					CHK	S. YAO			
					APP	I. ENOMOTO	NO	108-60043	REV
	LTR	REVISION RECORD	DR	DATE	PAGE	TITLE	O	ES	
					1 of 7	CHAMP .050 Series (II) Connector Wire to Board Type			

3. Requirements:

3.1 Design and Construction:

Product shall be of the design, construction and physical dimensions specified in the applicable product drawing.

3.2 Materials:

A. Contact:

Phosphor Bronze, Au Plating (0.1, 0.3 or 0.76 μ) on contact area over Ni under plating.

Soldering area : Matte tin Plating

LD area: Matte tin Plating

B. Housing:

Glass filled Thermo Plastic UL 94 V-0

C. SHELL

Zinc Die cast : Ni plating over Cu under plating

Steel: Ni plating over Cu under plating

Brass: Ni plating

D. Accessories and Hardware:

ENCLOSURE: Glass Filled Thermo Plastic UL 94-V-0

LOCKING SPRING: MOLDING PORTION: Thermo Plastic UL94V-0

SPRING PORTION: STAINLESS STEEL

3.3 Ratings:

A. Voltage Rating: 250 VAC

B. Current Rating: 1A, (AWG#28)
0.5A, (AWG#30)

C. Temperature Rating: -55°C to +85°C

3.4 Performance and Test Descriptions:

The product shall be designed to meet the electrical, mechanical and environmental performance requirements specified in Fig. 2. All tests shall be performed in the room temperature unless otherwise specified.

3.5 Test Requirements and Procedures Summary:

Para.	Test Items	Requirements	Procedures
3.5.1	Confirmation of Product	Product shall be conforming to the requirements of applicable product drawing and Application Specification 114-5124	Visually, dimensionally and functionally inspected per applicable inspection plan.
Electrical Requirements			
3.5.2	Termination Resistance (Low Level)	35 mΩ max. (Initial) ΔR=25 mΩ max. (Final)	Subject mated contacts assembled in housing to closed circuit current of 50 m A max, at open circuit voltage of 50 mV max. Fig. 4. AMP Spec. 109-5306
3.5.3	Insulation Resistance	500 MΩ min. (Initial) 100 MΩ min. (Final)	Measure by applying test potential between the adjacent contacts, and between the contacts and ground in the mated connectors.
3.5.4	Dielectric Strength	Connector must withstand test potential of 0.5 k VAC for 1 minute. Current leakage must be 0.5 mA max.	Measure by applying test potential between the adjacent contacts, and between the contacts and ground in the mated connectors. MIL-STD-202, Method 301

Fig. 2 (To be continued)

Para.	Test Items	Requirements	Procedures
Physical Requirements			
3.5.5	Vibration Sinusoidal Low Frequency	No electrical discontinuity greater than 1 microsecond (s) shall occur. See Note (a)	Subject mated connectors to 10-55-10 Hz traversed in 1 minute at 1.52 mm amplitude 2 hours each of 3 mutually perpendicular planes. MIL-STD-202, Method 201
3.5.6	Physical Shock	No electrical discontinuity greater than 1 microsecond (s) shall occur. See Note (a)	Subject mated connectors to 490.3 m/s ² halfsine shock pulses of 11 millisecond duration; 3 shocks in each direction applied along the 3 mutually perpendicular planes total 18 shocks; MIL-STD-202, Method 213, Condition A
3.5.7	Connector Mating Force	735.5 m N max. (initial) per contact	Measure the force required to mate connector using locking latch by operating at 100 mm a minute. Record by using autograph. Calculate the value for a contact. AMP Spec. 109-5206
3.5.8	Connector Unmating Force	196.1 m N min. (initial) per contact	Measure the force required to unmate connector without locking latch set in effect, by operating at 100 mm a minute. Calculate value for a contact.
3.5.9	Durability (Repeated Mate/Unmating)	Termination Resistance (Low Level) (Final) 35 mΩ max.	Mate and unmate connectors for 500 cycles at a maximum rate of 40 cycles /minute; AMP Spec. 109-27
3.5.10	Solderability	Solderable area shall have solder coverage of 95% minimum.	Subject contacts to solderability testing. MIL-STD-202, Method 208

Fig. 2 (To be continued)

Para.	Test Items	Requirements	Procedures
3.5.11	Connector Retention Force:	After testing, no breakage shall occur in locking area and cable retention area.	Apply an axial pull-off load of 98.1 N the cable terminated on the plug connector, which is mated with the header and the locking device is set in effect.
3.5.12	Repeated Bending of Cable:	No breakage of conductor shall occur.	With the free end of the terminated cable securely fixed, repeat bending of the to 60°C both sides with tension load of 4.9 N applied, for 2,000 cycles reciprocatingly, by moving the connector side. Fig. 5
3.5.13	Resistance to Soldering Heat	No physical damage	Subject connector mounted on printed circuit boards to solder bath at 260°C for 10 seconds. MIL-STD-202, Method 210
Environmental Requirements			
3.5.14	Thermal Shock	Termination Resistance; (LOW LEVEL) (FINAL)	Subject mated connectors to 5 cycles between -55°C and 85°C MIL-SRD-202, Method 107, Condition A.
3.5.15	Humidity-Temperature Cycling	Insulation Resistance (Final) 100 MΩ min. Termination Resistance (Low Level) (Final)	Subject mated connectors to 10 cycles of humidity-temperature changes between 25°C and 65°C at 95% R. H. MIL-STD-202, Method 106
3.5.16	Humidity, steady State	Insulation Resistance (Final) 100 MΩ min. Termination Resistance (Low Level) (Final)	Subject mated connectors to steady state humidity at 40 °C and 90-95% R. H. MIL-STD-202, Method 103, Condition B (96 Hr)
3.5.17	Temperature Life	Termination Resistance (Low Level) (Final)	Subject mated connectors to temperature life; MIL-STD-202, Method 108 Condition B (85°C, 250 Hr)

Fig. 2 (End)

tyco Electronics	Tyco Electronics AMP Shanghai Ltd	PAGE 5	NO 108-60043	REV O	LOC ES
----------------------------	--------------------------------------	-----------	-----------------	----------	-----------

3.6 Product Qualification Sequence

Test or Examination	Test Group											
	1	2	3	4	5	6	7	8	9	10	11	12
	Test Sequence (a)											
Examination of Product	1,9	1,6	1,3	1,3	1,5	1,7	1,5	1,5	1,5	1,7	1,3	1,3
Termination Resistance, Dry Circuit	2,8	2,5			2,4		2,4	2,4	2,4			
Dielectric Withstanding Voltage						2,5				2,5		
Insulation Resistance						3,6				3,6		
Vibration		3										
Physical Shock		4										
Mating Force	3,6											
Unmating Force	4,7											
Durability	5											
Solderability												2
Resistance to Soldering Heat											2	
Thermal Shock							3					
Humidity-Temperature Cycling					3	4						
Humidity-Temperature Cycling									3	4		
Temperature Life								3				
Connector Tensile Strength			2									
Repeated Bending of Cable				2								

(a) Numbers indicate sequence in which tests are performed.

Product Part No.	Descriptions
5178238	Rec. Header (R/A) 3.1 mm Tine STD Type (W/Retention Leg)
5178240	Rec. Header (R/A) 2.2 mm Tine STD Type (W/Retention Leg)
5179717	Rec. Header (R/A) 3.1 mm Tine Latching Ears Cut Type (W/Retention Leg)
5175887	Rec. Header (R/A) 3.1 mm Tine, M2.6
5917334	Rec. Header (R/A) 3.1 mm Tine, M2.6 (W/Retention Leg)
175753	Shield Case Kit without Logo
175755	Shield Case Kit with AMP Logo
176792	Shield Case Kit STD Type without Logo
176793	Shield Case Kit STD Type with AMP Logo
176324	Shield Case Kit 14 Pos. with Key STD Type without Logo
176267	Shield Case Kit 20 Pos. with Key STD Type without Logo
177618	Shield Case Kit 26 Pos. with Key STD Type without Logo
176269	Shield Case Kit 50 Pos. with Key STD Type without Logo
176268	Shield Case Kit 14 Pos. with Key STD Type with AMP Logo
178849	Shield Case Kit 20 Pos. with Key STD Type with AMP Logo
178850	Shield Case Kit 36 Pos. with Key STD Type with AMP Logo
178851	Shield Case Kit 50 Pos. with Key STD Type with AMP Logo
175997	Shield Case Kit 26 Pos. with Key (Original) Type without Logo
178361	Rec. HDR (R/A) 2.7 mm Tine Screw Lock Type
178375	Shield Case Kit Screw Lock Type
175751	Plug Connector Kit for SCSI Cable AWG #28 0.7~0.9 DIA
178781	Shield Case Kit for SCSI Cable with AMP Logo
178782	Shield Case Kit for SCSI Cable without Logo
917098	Shield Case Kit 50 Pos. for SCSI Cable STD Type with AMP Logo
316125	Shield Case Kit 50 Pos. for SCSI Cable STD Type without Logo
179716	Shield Case Kit Jack Screw Type without Logo

Fig. 1 (end)

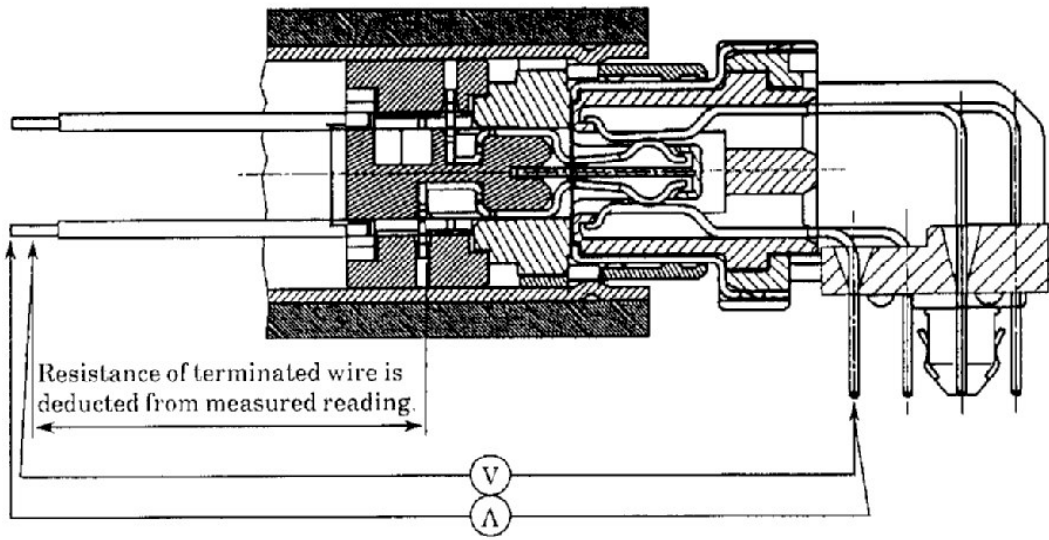

Fig.4

tyco <i>Electronics</i>	Tyco Electronics AMP Shanghai Ltd	PAGE 8	NO 108-60043	REV O	LOC ES
-----------------------------------	--------------------------------------	------------------	-----------------	----------	-----------

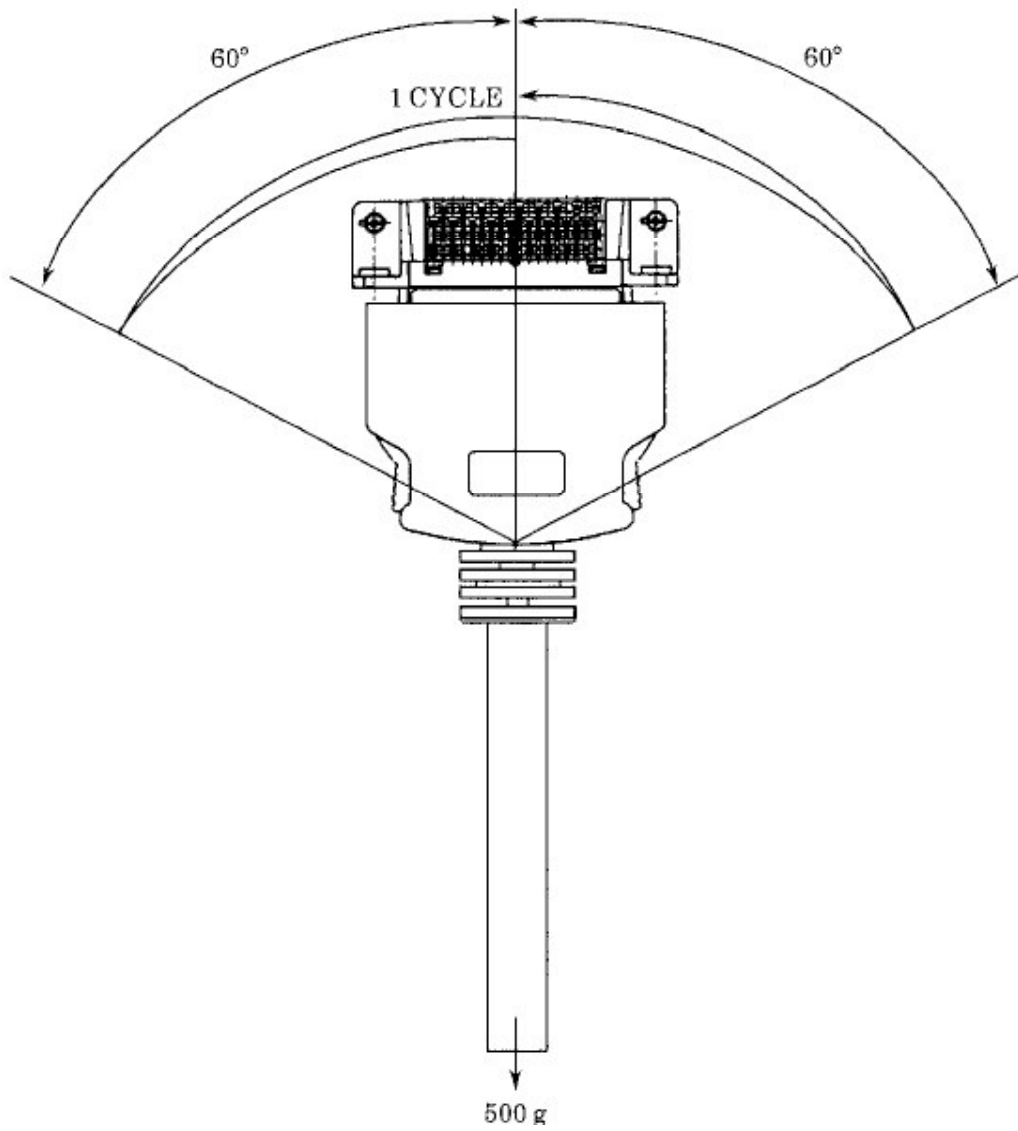

Fig.5

tyco <i>Electronics</i>	Tyco Electronics AMP Shanghai Ltd	PAGE 9	NO 108-60043	REV O	LOC ES
-----------------------------------	--------------------------------------	------------------	-----------------	----------	-----------