SHIELD FINGER

1. SCOPE

This specification covers performance, tests and quality requirements for Shield Finger.

2. APPLICABLE DOCUMENT

The following documents form a part of this specification to the extent specified herein. In the event of conflict between the requirements of this specification and the product drawing, the product drawing shall take precedence. In the event of conflict between the requirements of this specification and the referenced documents, this specification shall take precedence.

Test Report : 501-57609

3. REQUIREMENTS**3.1. DESIGN AND CONSTRUCTION**

Product shall be of the design, construction and physical dimensions specified on the applicable product drawing.

3.2. MATERIALS

Contact : Copper Alloy,

Contact Area : Gold plating

Foot Area : Tin plating

DR	DATE	APVD	DATE
Jerry Cheng	07-DEC-2004	W.J.KE	07-DEC-2004

FZ00-0299-04

3.3. TEST CONDITION

The product is designed to meet the mechanical and environmental performance requirements specified in Figure 1.

3.4. TEST REQUIREMENTS AND PROCEDURES SUMMARY

TEST DESCRIPTION	REQUIREMENT	PROCEDURED
Examination of Product	Meets requirements of product drawing and AMP Specification.	Visual inspection No physical damage
ELECTRICAL		
Contact Resistance	20mΩ Max.	As spring height 0.5mm MIL-STD-1344, Method 3002.1
MECHANICAL		
Spring Capacity	Spring Force : 100gf MIN. Spring height : 3.5mm (AFTER PRESSURE)	Measure the spring force , after making 5 times flexion at a speed of 2mm/min. a cycle.
ENVIRONMENTAL		
Solderability	The test area shall be covered more than 75% of immersed area with fresh solder.	Temperature : 235±5°C , 3±0.5sec.

Figure 1

3.5. PRODUCT QUALIFICATION AND REQUALIFICATION TEST SEQUENCE

Test or Examination	Test Group		
	A	B	C
	Test Sequence (a)		
Examination of Product	1,3	1	1
Contact Resistance		2	
Spring Capacity	2		
Solderability			2

Figure 2.

NOTE : (a) The numbers indicate sequence in which tests were performed.

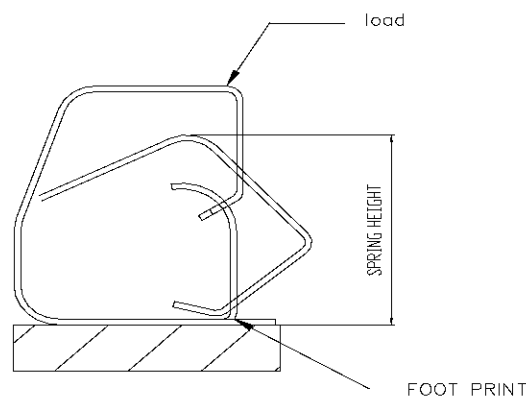

Figure 3