



## 2. APPLICABLE DOCUMENTS

2.1. Applicable portions of the following documents form a part of the manufacturing control of this product.

- A. **MIL-G-45204**: Gold Plating, Electrodeposited
- B. **MIL-T-10727**: Tin Plating, Electrodeposited

2.2. The following documents describe handling and use of this product:

- A. 109-9000: Packaging Components Division Connector Test Methods
- B. MIL-STD-1344: Test Methods for Electrical Connectors

## 3. PERFORMANCE REQUIREMENTS

### 3.1. Ratings

- A. Current: 1.5 amperes maximum per contact
- B. Temperature: -55° to 105°C

### 3.2. Test Requirements and Procedures Summary

Test Description	Requirement	Procedure
Examination of Product	Meet requirements of drawing.	Dimensional and <b>visual</b> .
Connector Mating Force	12.0 ounces maximum average per contact.	Receptacle assembly <b>with flexible flat cable</b> shall be used for this test.
Termination Resistance, Low Level	.020 ohm maximum initial, .030 ohm maximum final.	50 mv maximum open circuit, 100 ma maximum short circuit.
Termination Resistance, Rated Current	.020 ohm maximum initial, .030 ohm maximum final.	1.5 amperes.
Connector Unmating Force	2.0 ounces minimum average per contact.	Receptacle assembly with flexible flat cable shall be used for this test.
Contact Separation Force	0.9 ounce minimum.	Check with minimum thickness gage .008.
Thermal Shock	No evidence of physical damage.	-55° to 105°C, 5 cycles.
Durability	No evidence of physical damage. Meet contact separation force.	25 mating and unmating cycles using typical flexible flat conductor cable contacts.

**AMP**

AMP INCORPORATED  
Harrisburg, Pa.

SHEET

2 OF 4

LOC

**B**

NO

**A** 108-33000

REV

0

NAME

INTERCONNECT, LOW PROFILE STRIP  
RECEPTACLE TO FLEXIBLE FLAT  
CABLE SOLDER TABS

Figure 1 (cont)

Test Description	Requirement	Procedure
Vibration	No interruption of continuity greater than 1 microsecond. No physical damage.	10-2000 Hz; 15 G peak; mated; energized with 100 milliamperes dc current.
Physical Shock	No interruption of continuity greater than 1 microsecond. No physical damage.	100 G peak, 6 milliseconds sawtooth; mated; energized with 100 milliamperes dc current.
Humidity, Steady State	Termination resistance, low level and rated current, final.	90-95% RH, 40°C, 96 hours.
Salt Spray (Corrosion)	Termination resistance, low level and rated current, final.	5% solution, 48 hours.
Industrial Gas, (Corrosion)	Termination resistance, low level and rated current, final.	SO <sub>2</sub> environment, 24 hours.

Figure 1 (end)

3.3. Connector Tests and Sequence

Test or Examination	MIL-STD-1344 Method	109-9000 Requirement Paragraph	Test Sequence(a)	
			1	2
Examination of Product		5.1.	X	X
Connector Mating Force	2013.1	5.8.		X
Termination Resistance, Low Level (c)	3002.1	5.2.	X	X
Termination Resistance, Rated Current (c)	3004.1	5.3.	X	X
Connector Unmating Force	2013.1	5.9.	X	X
Contact Separation Force (d)	2014	5.7.	X	X
Temperature Cycling (b)	1003.1, Cond A	5.11.	X	X
Durability Contact Separation Force	2016	5.10.	X	X
Vibration	2005.1, Cond III	5.12.	X	
Physical Shock	2004.1, Cond G	5.13.	X	X
Humidity (e)	1002.2, Cond B	5.14.	X	
Salt Spray (Corrosion) (f) (g)	1001.1, Cond B	5.15. B.		X
Industrial Gas (Corrosion) (f) (g)		5.15. A.		X

- (a) Samples are mounted on PC board.
- (b) Upper temperature limit 105°C.
- (c) See Figure 4.
- (d) See Figure 3.
- (e) Tin plated contacts only.
- (f) Gold plated contacts only.
- (g) One half the test samples shall be subjected to salt spray and the other half to industrial gas.

Figure 2

SHEET <u>3</u> OF <u>4</u>	<b>AMP</b>		AMP INCORPORATED Harrisburg, Pa.	
	LOC <b>B</b>	NO <b>A</b>	<b>108-33000</b>	REV <b>0</b>
NAME INTERCONNECT, LOW PROFILE STRIP RECEPTACLE TO FLEXIBLE FLAT CABLE SOLDER TABS				

### 3.4. Selection of Test Samples

Test samples shall consist of 2 connectors of each material and plating finish.

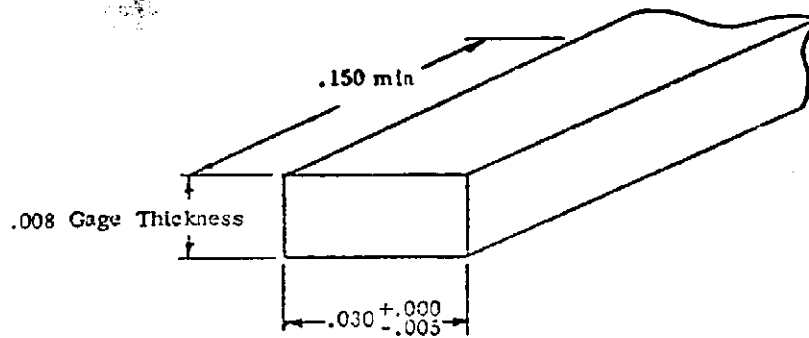

- Notes: 1. Break all edges.  $.002 \begin{smallmatrix} +.001 \\ -.000 \end{smallmatrix}$  R max  
 2. Provide 4 microinch finish.  
 3. Material: Tool steel, hardness to Rockwell C60-65.

Figure 3  
Withdrawal Gage

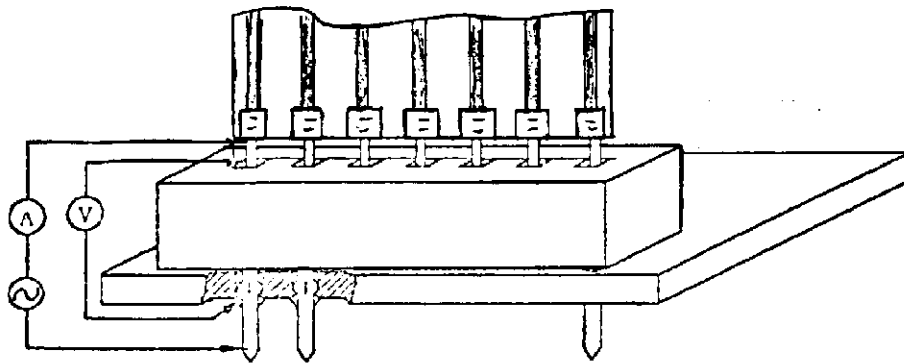

Note: Measure resistance as close as possible to socket.

Figure 4  
Termination Resistance

<b>AMP</b>		AMP INCORPORATED Harrisburg, Pa.		SHEET	
				4 OF 4	
LOC B	A	NO 108-33000	REV 0		
NAME INTERCONNECT, LOW PROFILE STRIP RECEPTACLE TO FLEXIBLE FLAT CABLE SOLDER TABS					