**SAE J1772 Electric Vehicle Charge Connector Cable Assembly
(Type 1 / Level 2) UL Standard and SAE Based**

1. SCOPE

1.1. Content

This specification covers performance, tests and quality requirements for the TE Connectivity (TE) SAE J1772 EV Cable Assemblies. The cable assemblies are designed to perform in accordance with “UL Standard for Safety, Plugs, Receptacles and Couplers for Electric Vehicles”, UL 2215 and “SAE Electric Vehicle and Plug In Hybrid Electric Vehicle Conductive Charge Coupler, Surface Vehicle Recommended Practice”, SAE J1772. Although cable diameters and assembly current ratings may vary, the mechanical and environmental requirements contained in this specification apply to all.

1.2. Qualification

When tests are performed on the subject product line, procedures specified in Figure 1 shall be used. All inspections shall be performed using the applicable inspection plan and product drawing.

1.3. Qualification Test Results

Successful qualification testing on the subject product line has not been completed. The Qualification Test Report number will be issued upon successful qualification testing.

2. APPLICABLE DOCUMENTS AND FORMS

The following documents and forms constitute a part of this specification to the extent specified herein. Unless otherwise indicated, the latest edition of the document applies.

2.1. TE Documents

- [108-32100-1](#): SAE J1772 Electric Vehicle Charge Connector Cable Assembly (Type 1 / Level 2) IEC Standard and VDE Based
- [501-19221](#): SAE J1772 Electric Vehicle Connector Cable Assemblies
- [502-153039](#): Tecca+ cable assemblies IP test to fail

2.2. Industry Documents

- UL 2215: UL Standard for Safety, Plugs, Receptacles and Couplers for Electric Vehicles”
- SAE J1772: SAE Electric Vehicle and Plug In Hybrid Electric Vehicle Conductive Charge Coupler, Surface Vehicle Recommended Practice
- EIA-364: Electrical Connector/Socket Test Procedures
- IEC 60529: International Standard, Degrees of Protection Provided by Enclosure (IP Code)

2.3. Reference Document

- [109-197](#) Test Specification (TE Test Specification vs EIA and IEC Test Methods)

3. REQUIREMENTS

3.1. Design and Construction

Product shall be of the design, construction, materials and physical dimensions specified on the applicable product drawing.

3.2. Ratings

- Operating Voltage: 230Vac or 150Vdc
- Current: See Figure 4 for applicable current carrying capability. Maximum rated current that can be carried by this product is limited by maximum operating temperature of the housings (105° C) and temperature rise of the housings (30° C). Variables to be considered for each application are: wire size, connector size, contact material, ambient temperature, and printed circuit board design.
- Temperature: -55 to 105°C

3.3. Test Requirements and Procedures Summary

Unless otherwise specified, all tests shall be performed at ambient environmental conditions.

TEST DESCRIPTION	REQUIREMENT	PROCEDURE
Initial / Final examination of product	Meets requirements of product drawing.	EIA-364-18. Visual and dimensional (C of C) inspection per product drawing.
MOLDED MATERIALS		
Accelerated Aging Test	No deterioration or hardness change greater than 10 numbers after more than 4 hours at 23±2.0°C (74±4°F).	UL 2251, Para. 25 Subject 3 specimens of molded rubber components to 70hrs at 100±1.0°C (212±1.8°F).
Mold Stress Relief Test	See Note.	UL 2251, Para. 26 Subject 3 specimens of molded thermoplastic components to 7hrs @ T-rise test temperature plus 10°C (18°F) or 80°C (176°F) minimum.
ELECTRICAL		
Termination Resistance, Dry Circuit.	Maximum ΔR 1mOhm through interface and terminations, wire bulk removed.	EIA 364-6B Subject specimens to 100 mA maximum and 20 mV maximum open circuit voltage. See Figure 2
Termination Resistance, Specified Current.	Maximum ΔR 1mOhm through interface and terminations, wire bulk removed.	EIA 364-6B Test current per Table 1 and Figure 2.
Insulation Resistance Test.	Less than 5megaOhm	UL 2251, Para. 29 Subject 2 mated and 2 unmated specimens between all poles connected together and the body, and between each pole in turn and all others at 500Vdc for 1 minute.
Withstanding Voltage Test.	1 minute hold with no breakdown or flashover, no exposure of live parts and no deformation that effects mating polarization or proper functioning of specimen	UL 2251, Para. 30 Subject 2 unmated specimens between live parts of opposite polarity, secondary circuits and ground, and secondary circuits and live parts to 2000Vac at 50 – 60Hz, uniformly and rapidly applied.
Grounding Path Current Test	See Note	UL 2251, Para. 38 Subject 3 mated specimens with 609mm (24") minimum cable as specified in Table 2
Electromagnetic Test	See Note	UL 2251, Para. 44 Subject 3 mating specimens for 50 mating cycles at rated current and voltage followed by 6000 cycles at 110% of load from Table 5. Mate the first 10 cycled as quickly as possible, the next 990 at a rate of 2 seconds per cycle and the remainder at a maximum rate of 10 cycles per minute.
Current Cycling	See Note. Maximum Temperature Rise to be 50°C (122°F) above ambient. Maximum Dry Circuit ΔR 1mOhm through interface and terminations, wire bulk removed.	EIA 364-55 Subject 3 mating specimens for 50 cycles of 2 hours with Current ON followed by 1 hour Current OFF at 130% of rated current. See Figure 2

TEST DESCRIPTION	REQUIREMENT	PROCEDURE
MECHANICAL		
No-Load Endurance Test	See Note.	UL 2251, Para. 41 Subject 3 mating specimens for 10,000 mating cycles at a maximum rate of 10 cycles per minute with no load applied. Every 1000 cycles, assembly is to be dipped in salt, sand and distilled water solution (see ISO 12103-A4) in natural resting position for 5 seconds maximum and allowed to dry completely.
Insertion/Withdrawal Force Test	Withdrawal force to be greater than insertion force but greater than minimum force specified in Table 4	UL 2251, Para. 37 Subject 4 assembled mating specimens, cable not required. Measure force required to insert and withdraw mating connectors with the locking mechanism disabled. Specimens to be mounted so that the longitudinal axes of the contacts are vertical with the contact openings facing downward.
Conductor Secureness and Pullout Test	No break or loosening of connection	UL 2251, Para. 32 Subject 3 of each applied conductor size. Apply force between contact and wire at a maximum rate of 12.7mm [0.5 in] per minute until test requirement (See Table 1) is reached then hold for 1 minute.
Cable Secureness Test	At completion of each test segment, no axial displacement of conductors or insulation exceeding values specified in Table 3	UL 2251, Para. 33 Subject 3 assembled specimens with 305mm (12") minimum of minimum diameter cable. Apply force 150mm (~5.9") maximum from cable clamp. Apply axial force between housing and cable at a maximum rate of 12.7 mm [0.5 in] per minute until test requirement (See Note) is reached then hold for 1 minute. Apply torque in least favorable direction as require (See Table 3) then hold for 1 minute.
Impact Test	See Note	UL 2251, Para. 34 Subject 3 assembled specimens with 2250mm (~90") of maximum diameter cable conditioned for 6 hours at -30±2°C (-22±3.6°F). Fix horizontally 1000mm (~39.4") above a concrete surface. Drop to surface 8 times, rotating cable assembly 45° at fix point between each drop.
Crush Test	See Note	UL 2251, Para. 35 Subject 3 specimens assembled to minimum diameter cable conditioned for 6 hours at -30±2°C (-22±3.6°F). Place between 2 parallel 457mm (18") long steel plates in a natural resting position. Apply crushing force at a rate of 10.0±2.5mm (~1/2±1/8") per minute up to 890N (200lbf) and hold for 1 minute.

Figure 1 cont.

TEST DESCRIPTION	REQUIREMENT	PROCEDURE
Vehicle Drive over Test	See Note	UL 2251, Para. 36 Subject 3 specimens assembled to minimum diameter cable, placed on a concrete floor in the natural resting position and held to prevent movement. Apply crushing force of 4893N (1100lbf) delivered by a P255/75R15 conventional vehicle tire inflated to 218±13kPa (32±2psi) traveling at a speed of 8±2km/h (5±1.25mph).
Polarization Integrity Test	No mating in any manner that would energize the grounding feature of the device.	UL 2251, Para. 49 Subject 3 mating samples, with polarization feature removed from the cable connector face, to attempts at mating in any manner with the application of a force of 180N (40lbf) other than correct orientation.
ENVIRONMENTAL		
Humidity Conditioning	See Note.	UL 2251, Para. 28 Subject 2 mated specimens at 32+4/-0°C (89.6+7.2/-0°F) for 4hrs, then subject specimens to 168hrs (7 days) at 32±2°C (89.6±3.6°F) at 93±2% RH.
Dew Point Test	See Note – Perform test 1 minute after specimen is placed in humidity chamber.	UL 2251, Para. 31 Subject 3 specimens wrapped in 100 X 200mm (4" X 8") of foil at 5±2°C (41±3.6°F) for 4hrs, then transfer within 1 minute to humidity chamber at 32±2°C (89.6±3.6°F) at 93±2% RH for 1 minute.
Enclosure Tests for Environmental Protection	See Note.	UL 2251, Para. 54, Designation 6 Subject 2 specimens, 1 mated and 1 unmated, to IEC 60529 Test Condition Clauses 13.4 and 13.6, Category 2 (Solid Foreign Objects) and 14.2.6 (Water)

i **NOTE** *Shall meet visual requirements, show no physical damage as specified below (“a” through “f”), and meet requirements of additional tests as specified in the Product Qualification and Requalification Test Sequence shown in Figure 2. Cable secureness force to be calculated as 1.03N/mm² (~150lbf/in²) times the cable cross-sectional area rounded to nearest 22N (~5lbf) force, but not less than 156N (~35lbf).*

- a) Making uninsulated live parts accessible to contact by the probe illustrated in Figure 3
- b) Defeating the integrity of the enclosure so mechanical protection is not afforded or polarization is defeated.
- c) Operation, function or installation of the device that allows the user to be exposed to a hazard. The retaining means to hold mating devices together are permitted to sustain damage if it does not interfere with the safe operation of the device.
- d) A condition that results in the device not complying with the strain relief requirements
- e) A reduction of spacing between uninsulated live parts or ground.
- f) Any other evidence of damage that could increase the risk of fire or electric shock.

Figure 1 end

3.4. Product Qualification and Requalification Test Sequence

TEST OR EXAMINATION	TEST GROUP (a)																
	1	2	3	4	5	6	7	8	9	10	11	12	13	14	15	16	17
	TEST SEQUENCE (b)																
Initial / Final examination of product	1,3	1,3	1,4	1,4	1,4	1,5	1,3	1,3	1,4	1,4	1,4	1,4	1,3	1,5	1,4	1,4	1,4
Termination Resistance, Dry Circuit				3	3												
Termination Resistance, Specified Current						2,4											3
Accelerated Aging Test	2																
Mold Stress Relief Test		2															
Insulation Resistance Test			2											3			
Withstanding Voltage Test			3						3	3	3	3		4	3	3	
Grounding Path Current Test				2													
Electromagnetic Test					2												
Current Cycling																	2
No-Load Endurance Test						3											
Insertion/Withdrawal Force Test							2										
Conductor Secureness and Pullout Test								2									
Cable Secureness Test									2								
Impact Test										2							
Crush Test											2						
Vehicle Drive over Test												2					
Polarization Integrity Test													2				
Humidity Conditioning														2			
Dew Point Test															2		
Enclosure Tests for Environmental Protection																2	



NOTE

- (a) Specimens shall be prepared in accordance with applicable Manufacturing Process Instructions (MPI) and shall be selected at random from current production. Each test group shall consist of quantities and design as described in the Procedure.
- (b) Numbers indicate sequence in which tests are performed.

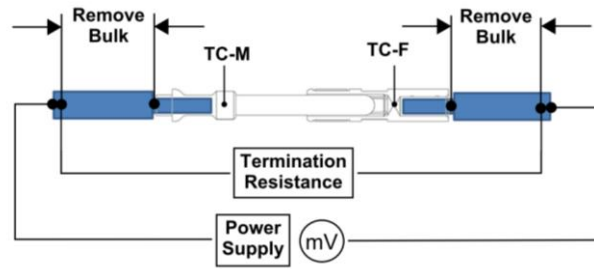

Figure 2
Temperature Rise and Contact Resistance Measurement Points (Circuit)

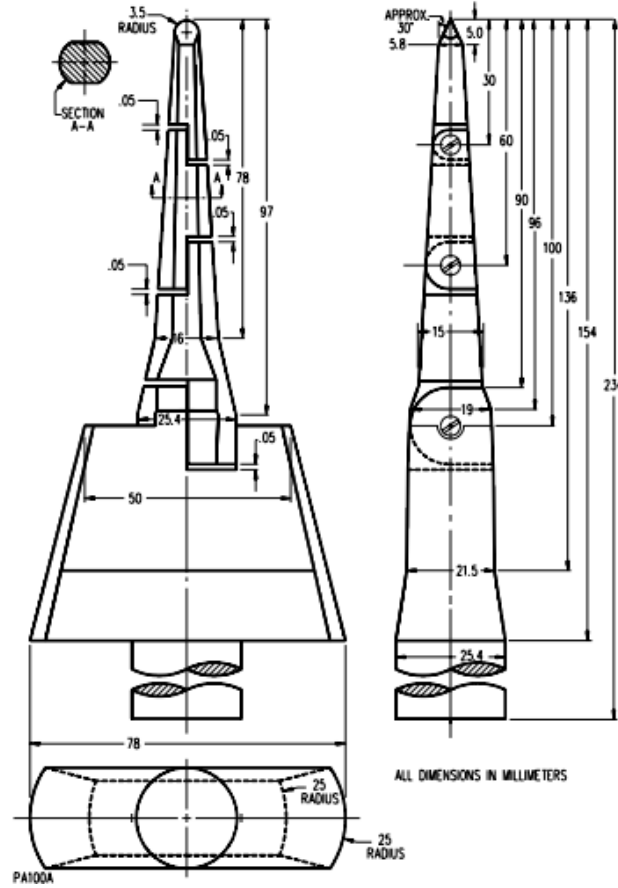

Figure 3
Articulate Probe

Table 1
Test Values for Current and Conductor Secureness

Size of conductor		Test current, Amperes	Pullout force	
AWG	mm ²		N	pounds
22	0.325	3	20	4.5
20	0.519	5	30	6.75
18	0.824	14	30	6.75
16	1.31	18	30	9.0
14	2.08	20	50	11.5
12	3.31	25	60	13.5
10	5.26	30	80	18.0
8	8.37	40	90	20.5

Table 2
Test Values for Ground Path Current

Device rating, Amperes	Size of Conductor		Time, Seconds	Test Current, Amperes
	AWG	mm ²		
0 – 15	14	2.08	4	300
16 – 20	12	3.31	4	470
21 – 60	10	5.26	4	750
61 - 100	8	8.37	4	1180

Table 3
Test Values for Cable Secureness

Device rating Amperes	Torque Nm (ft-lb)	Maximum displacement mm (inches)
15	0.41 (0.3)	2.38 (3/32)
16–20	0.54 (0.4)	2.38 (3/32)
21–35	0.68 (0.5)	2.38 (3/32)
36–70	1.4 (1.0)	2.38 (3/32)
71–125	2.7 (2.0)	2.38 (3/32)

Table 4
Withdrawal force

Device rating, Amperes	Minimum force (a) Withdrawal, N (lbf)
15	18 (4)
16 - 20	22 (5)
21 – 32	27 (6)
33 - 63	27 (6)
64 - 125	27 (6)

(a) The withdrawal force includes the weight of the test plug or connector. If the weight of the mating device exceeds the specified withdrawal force, the mating device shall retain the test plug.

Table 5
Standard Electromagnetic Loads

Test potential in volts	Standard duty		Heavy duty	
	Normal current	Current inrush	Normal current	Current inrush
120 ac (a)	3.0	30	6.0	60
240 ac (a)	1.5	15	3.0	30
30 dc	3.0	30	6.0	60
125 dc (b)	1.1	-	2.2	-
250 dc (b)	0.55	-	1.1	-

(a) Power factor 0.35 or less.

(b) Inductive loads per UL 508 and ANSI/NEMA ICS2 Section 125