



Z-Rail Junction Box

108-2471-1

Connection System for Photovoltaic Panels

Contents

1.	SCOPE.....	3
1.1.	Content.....	3
1.2.	Qualification	5
2.	APPLICABLE DOCUMENTS.....	5
2.1.	TE Connectivity (TE) Documents	5
2.2.	Industry Documents	5
3.	REQUIREMENTS	6
3.1.	Design and Construction	6
3.2.	Materials.....	6
3.3.	Ratings.....	6
3.4.	Performance and Test Description.....	6
3.5.	Test Requirements and Procedures.....	7
3.6.	Qualification and Requalification Test Sequences	10
4.	QUALITY ASSURANCE PROVISIONS	11
4.1.	Qualification Testing.....	11
4.2.	Requalification Testing.....	11
4.3.	Acceptance	11
4.4.	Quality Conformance Inspection	11
5.	CERTIFICATION	12

1. SCOPE

1.1. Content

This specification covers the performance, tests and quality standards for the SOLARLOK* Z-Rail Junction box which allows the electrical connection between Photovoltaic (PV) panels. The SOLARLOK Z-Rail Junction box allows connection of the foils exiting the solar panel in one of three ways in separate part number configurations as described here:

- A. A spring clip contact secures the foil to the rail whose interface surface, with serrations, is in a vertical position (see Figure 1).

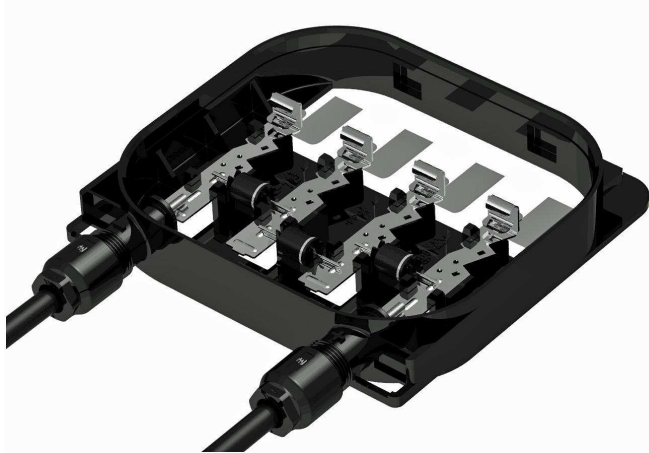

Figure 1 I



Figure 1 II

I. Z-Rail Foil Clip Version Used with Foil Clips PN 1740873-2 to Terminate Foils

II. Z-Rail S-Clip Version Used with S-clips PN 2232234-1 to Terminate Foils

B. The foil is welded to the rail whose interface surface (without serrations or foil clip) is in a vertical

Foils welded directly to rails

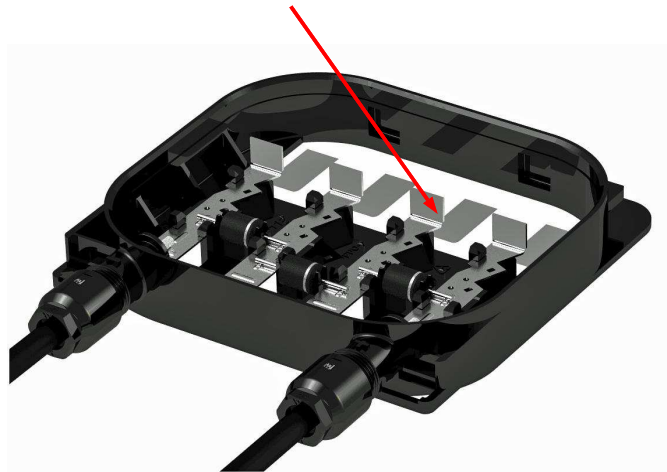

Figure 3
Z-Rail Box with Welded Foil Version

All Z-Rail Junction box part numbers have a bottom standoff version available.

The Z-Rail Junction Box allows for the replacement of diodes in the event of diode failure. A replacement diode is shown in Figure 4. See Instruction Sheet 408-10417 and Application Specification

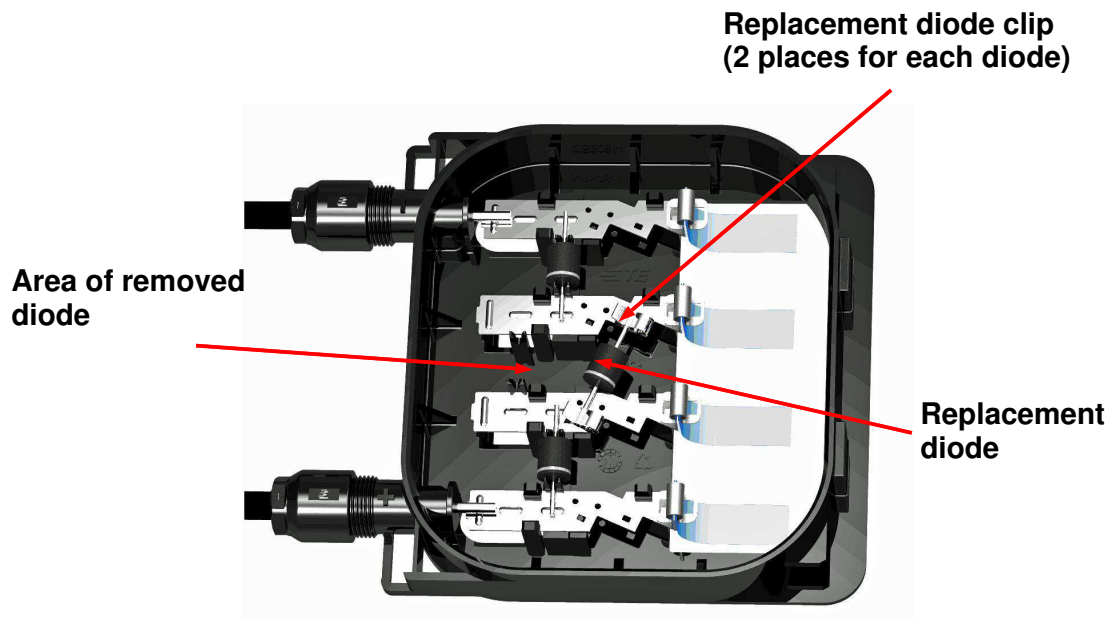

Figure 4
114-13303 for more details on replacement kits

Example of Replacement Diode Shown in Middle Position (All 3 Diodes Are Repairable)

The side-printed model code on the box describes the configuration of the box as well as components used (see Figure 5).

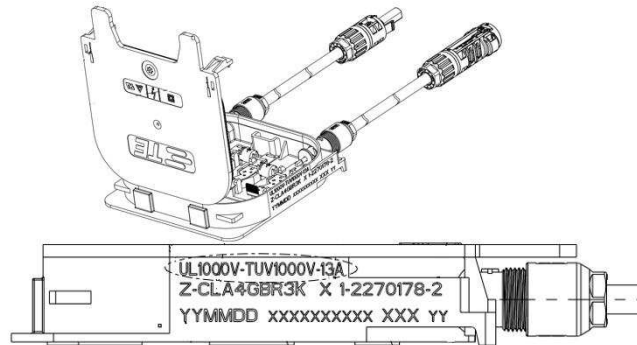

Figure 5
Standard Z-Rail Box Shown with Model Code

1.2. Qualification

When tests are performed on the subject product line, procedures specified in Figure 1 shall be used. All inspections shall be performed using the applicable inspection plan and product drawing.

2. APPLICABLE DOCUMENTS

The following documents form a part of this specification to the extent specified herein. Unless otherwise specified, the latest edition of the document applies. In the event of conflict between the requirements of this specification and the product drawing, the product drawing shall take precedence. In the event of conflict between the requirements of this specification and the referenced documents, this specification shall take precedence.

2.1. TE Connectivity (TE) Documents

- 114-13303-1: Application Specification (SOLARLOK* Z-Rail Junction Box Assemblies)
- 404-74000-1: Model Code for SOLARLOK* System
- 408-10417: Instruction Sheet (SOLARLOK* Z-Rail Junction Box Assemblies)
- 501-TBD: Qualification Test Report (SOLARLOK* Z-Rail Junction Box)
- Customer drawings(TYP.)
 - Foil clip(omega clip) version: 2270178 (with base standoffs)
 - Foil clip(S clip) version: 2270176 (with base standoffs)
 - Welded foil version: 2270267 (with base standoffs)

2.2. Industry Documents

- IEC62790:2014:Junction boxes for photovoltaic modules – Safety requirements and tests
- UL3730: Standard for Safety Photovoltaic Junction Boxes
- EIA-364: Electrical Connector/Socket Test Procedures Including Environmental Classifications
- IEC 60068-2-2: Environmental Testing - Part 2-2 - Test B, Dry Heat
- IEC-60512: Electronic Equipment - Tests and Measurements
- IEC 60529: Degrees of Protection Provided by Enclosures (IP Code)
- IEC-60695: Fire Hazard Testing
- IEC 61215: Crystalline Silicon Terrestrial Photovoltaic (PV) Modules - Design Qualification and Type Approval
- IEC-61701: Salt Mist Corrosion Testing of Photovoltaic (PV) Modules
- UL 1703: UL Standard for Safety Flat-Plate Photovoltaic Modules and Panels

3. REQUIREMENTS

3.1. Design and Construction

Product shall be of the design, construction and physical dimensions specified on the applicable production drawing.

3.2. Materials

Materials used in the construction of this product shall be as specified on the applicable product drawing.

3.3. Ratings

- Rated voltage, box: TUV 1000 volts/ UL 1000 volts up to TUV 1500 volts/ UL 1500 volts
- Rated impulse voltage, box: TUV 12kV up to 16kV
- Rated Module working voltage: TUV < 50 V
- Pollution degree: 3 (2 inside of enclosure)
- TUV Rated reverse current: 30 A
- TUV Rated bypass current (Isc) see TUV Rheinland certification
- Operating temperature: -40 to 115°C *
- Storage temperature: -40 to 85°C
- Maximum ambient temperature per UL: 75°C at full load
- Degree of protection: IP65/IP 67 for box
- Wire size 4 mm² stranded wire

For rating of connectors see applicable specification of this connector.

**) ambient temperature (per IEC 85°C) and heating by current*

3.4. TÜV Approved cables

- TE Connectivity, cable PN 2270215-x, 4 mm² (12 AWG), TÜV Rheinland cert.: R 50504538 & R 50504540. Type designation: SLKC1A4.
- TE Connectivity, cable PN 2270259-x, 4 mm² (12 AWG), TÜV Rheinland cert.: R 50504538 & R 50504540. Type designation: SLKC0A4.
- TE Connectivity, cable PN 2270245-x, 4 mm² (12 AWG), TÜV Rheinland cert.: R 50504531 & R 50504536. Type designation: SLKC1B4.
- TE Connectivity, cable PN 2270260-x, 4 mm² (12 AWG), TÜV Rheinland cert.: R 50504531 & R 50504536. Type designation: SLKC0B4.

3.5. Performance and Test Description

Product is designed to meet the electrical, mechanical and environmental performance requirements specified in Figure 6. Unless otherwise specified, all tests shall be performed at ambient environmental conditions.

3.6. Test Requirements and Procedures

Test Description	Requirement	Procedure according
GENERAL INSPECTIONS		
Visual- and dimensional examination	Meets requirements of product drawing	DIN IEC 60512-2, Test 1a and 1b
ELECTRICAL INSPECTIONS		
Voltage proof	Value and nature of test voltage: 6 kV _{DC}	IEC 60512-2, test 4a Time of testing: 60s
Isolation test	3000VDC R > 400MΩ at 1000VDC	IEC 61215 10.3
Wet leakage current.	Water/wetting agent shall have a resistivity of 3500 ohms/cm or less at a temperature of 22 ± 3°C. R > 400 MΩ at 1000 volts DC.	IEC 61215 10.15.
Overall resistance (DC)	Resistance for each contact point: < 5 mΩ (1 milliohm typical)	IEC 60512-2, Test 2b
Bypass-Diode thermal test	T _{amb} =75°C I ₂ =1.25 * I ₁ 1 Bypass-Diode I ₁ =5A 2 Bypass-Diode I ₁ =4A or experimental determination T _{diode} < T _{junc}	IEC 61215 10.18
Current carrying capacity (derating-curve)	I _{max} /Box = 20 A ΔT = 30K See derating-curve page 16	IEC 60512-3, Test 5a/5b
MECHANICAL INSPECTIONS		
Foil retention force for contact rail ass'y	Retention force min. 4N	Steel gauge: 5mm x 0.2mm Surface roughness: Rz 2.0μm Test speed 25 mm/min
Protection Degree	IP 67 then voltage proof SK II	IEC 60529
Strain relief	89 N	UL 1703, Section 22 Time of testing: 60s

MECHANICAL INSPECTIONS		
Impact (UL).	No accessible live parts	UL 1703, Section 30
Tension and torque	Tensile force 50 x 30 N Displacement < = 2mm Torque 0.15 Nm Rotation < = 45 degrees.	EN50548:2011+A1:2013, 5.3.21
Vibration (sinus)	No physical damage. No discontinuities greater than $t > 1\mu s$ Freq. 10-60Hz => 0.7mm(pk/pk) 60-500Hz/5g 2.5h per axis 3 axis direction 1 Oct./min	IEC 60512-4, test 6d
ENVIRONMENTAL INSPECTIONS		
Change of temperature	I = 2 A No physical damage. Maximum over all resistances must not be exceeded.	IEC 61215; 10.11 Ta = -40°C Tb =+ 85 °C Number of cycles: 50
Change of temperature	I = 2 A No physical damage. Maximum over all resistances must not be exceeded.	IEC 61215; 10.11 Ta = -40°C Tb =+ 85 °C Number of cycles: 200
Humidity freeze	No physical damage. Maximum over all resistances must not be exceeded. No discontinuous.	IEC 61215 10.12 Temperature: +85°C Temperature: -40°C Rel. humidity: 85% Number of cycles: 10
Damp heat	No physical damage	IEC 60068-2-3, test Ca Temperature +85 °C Rel. humidity: 85% Duration: 1000 h
Salt mist test	2 Weeks at position of use Maximum over all resistances must not be exceeded.	IEC 60068-2-11 Ka
ENVIRONMENTAL INSPECTIONS		
Rapid change of temperature	No physical damage	IEC 60512-6 test 11d Ta = -40°C Tb = +115°C ta = 15 min. tb =15 min. Time of cycles tyk = 30 minutes Number of cycles: 100
Industrial atmosphere	No physical damage	IEC 60068-2-60: Test Ke/ meth. 4 75% damp: T =25°C Duration time: 10 Days

Type Approval Tests(3 rd Party)		
Type approval tests 1		IEC62790:2014 Junction boxes for photovoltaic modules – Safety requirements and tests To be done at TÜV Rheinland test lab
Type approval tests 1		UL 3730 UL Standard for Safety for Photovoltaic Junction Boxes To be done at UL test lab

3.7. Qualification and Requalification Test Sequences

Test	Test group ⁽¹⁾											
	A	B	C	D	E	F	G	H	I	J	K	L
	Test sequence ⁽²⁾											
Visual and dimensional examination	1, 6	1, 6	1, 7	1, 10	1, 7	1, 4	1, 6	1, 4	1, 6	1, 8	1, 4	
Voltage proof				2, 9	4		5					
Isolation test		2, 4	2, 4	4, 8						2, 7		
Wet leakage current	5	5	6	5, 7	5	3			4	4, 6	3	
Bypass-Diode	3											
Overall resistance (DC)	2, 4						2, 4	2, 5	2, 5			
Current carrying capacity (derating-curve)							3					
Foil retention force for contact rail assy									3			
Protection Degree (IP67)					3							
Tension and torque						2						
Strain relief			5		6							
Could impact (UL)											2	
Vibration (sinus)								3				
Heat secureness of isolation parts					2							
Change of temperature 50 cycles										3		
Change of temperature 200 cycles		3										
Humidity Freezing test			3							5		
Damp heat				6								
Salt mist test								4				
Rapid change of temperature				3								
Industrial atmosphere												

(1) See Para. 4.1 A

(2) Numbers indicate sequence in which tests are performed.

Classification of test groups:

Groups A, B, C, D, E, F, G, H, I, J, K

4. QUALITY ASSURANCE PROVISIONS

4.1. Qualification Testing

A Sample selection

The samples shall be prepared in accordance with product drawings. They shall be selected at random from current production.

Test group complete assemblies incl. solar panels

B Test sequence

The samples shall be prepared in accordance with product drawings. They shall be selected at random from current production.

4.2. Requalification Testing

If changes significantly affecting form, fit, or function are made to the product or to the manufacturing process, product assurance shall coordinate requalification testing, consisting of all or part of the original testing sequence as determined by development/product, quality, and reliability engineering.

4.3. Acceptance

Acceptance is based on verification that the product meets the requirements of Para. 3.5. Failures attributed to equipment, test setup, or operator deficiencies shall not disqualify the product. When product failure occurs, corrective action shall be taken and samples resubmitted for qualification. Testing to confirm corrective action is required before resubmitted.

4.4. Quality Conformance Inspection

The applicable AMP quality inspection plan will specify the sampling acceptable quality level to be used. Dimensional and functional requirements shall be in accordance with the applicable product drawing and this specification.

5. CERTIFICATION

TÜV Rheinland certification: see certification number R 60124095

UL certification: see UL file number E226440

List of product variations in TÜV Rheinland certification

Product overview of versions used with PV-cable													
Basic designation	Rails	No connectors	+ -	- +	TUV/UL 4.0mm ² /AWG12 ⁶⁾	No. of diodes	Rated current 13A ¹⁾	Rated current 12A ²⁾	Rated current 11A ³⁾	Rated current 9.5A ⁴⁾	Rated current 6.5A ⁵⁾	Additional suffix	
Z-CLA	4	G	A	--	N/R/X/Y	3	K					--	
Z-CLA	4	G	--	B	N/R/X/Y	3	K					--	
Z-WEL	4	G	A	--	N/R/X/Y	3	K					--	
Z-WEL	4	G	--	B	N/R/X/Y	3	K					--	
Z-CLA	4	G	A	--	N/R/X/Y	3		N				--	
Z-CLA	4	G	--	B	N/R/X/Y	3		N				--	
Z-WEL	4	G	A	--	N/R/X/Y	3		N				--	
Z-WEL	4	G	--	B	N/R/X/Y	3		N				--	
Z-CLA	4	G	A	--	N/R/X/Y	3			J			--	
Z-CLA	4	G	--	B	N/R/X/Y	3			J			--	
Z-WEL	4	G	A	--	N/R/X/Y	3			J			--	
Z-WEL	4	G	--	B	N/R/X/Y	3			J			--	
Z-CLA	4	G	A	--	N/R/X/Y	3				H		--	
Z-CLA	4	G	--	B	N/R/X/Y	3				H		--	
Z-WEL	4	G	A	--	N/R/X/Y	3				H		--	
Z-WEL	4	G	--	B	N/R/X/Y	3				H		--	
Z-CLA	4	G	A	--	N/R/X/Y	3					D	--	
Z-CLA	4	G	--	B	N/R/X/Y	3					D	--	
Z-WEL	4	G	A	--	N/R/X/Y	3					D	--	
Z-WEL	4	G	--	B	N/R/X/Y	3					D	--	
Z-CLA	3	G	D	--	N/R/X/Y	2	K					--	
Z-CLA	3	G	--	F	N/R/X/Y	2	K					--	
Z-CLA	3	G	D	--	N/R/X/Y	2	K					-2	
Z-CLA	3	G	--	F	N/R/X/Y	2	K					-2	

¹⁾ Bypass diode thermal tests performed with the back sheet Tedlar or glass with the diode: SL1515A(Obsoleted) or SL1515B or SL1515E
²⁾ Bypass diode thermal tests performed with the back sheet Tedlar or glass with the diode: SL 1515A(Obsoleted)
³⁾ Bypass diode thermal tests performed with the back sheet Tedlar or glass with the diode: SL1110B or SL1515B or SL1515E
⁴⁾ Bypass diode thermal tests performed with the back sheet Tedlar with the diode: SL1110(Obsoleted) or SL1110B or SL1515E
⁵⁾ Bypass diode thermal tests performed with the back sheet foil or glass with the diode: F1200DC
⁶⁾ TÜV 1000 V DC for N/R, 1500 V DC for X or Y

Product overview												
Basic designation	Rails	+	-	-	+	No terminations	No Cable ⁵⁾	No. of diodes	Rated current 13A ¹⁾	Rated current 12A ²⁾	Rated current 11A ³⁾	Rated current 9.5A ⁴⁾
Z-CLA	4	A	--			G	A	3	K			
Z-CLA	4	--		B		G	A	3	K			
Z-WEL	4	A	--			G	A	3	K			
Z-WEL	4	--		B		G	A	3	K			
Z-CLA	4	A	--			G	A	3		N		
Z-CLA	4	--		B		G	A	3		N		
Z-WEL	4	A	--			G	A	3		N		
Z-WEL	4	--		B		G	A	3		N		
Z-CLA	4	A	--			G	A	3			J	
Z-CLA	4	--		B		G	A	3			J	
Z-WEL	4	A	--			G	A	3			J	
Z-WEL	4	--		B		G	A	3			J	
Z-CLA	4	A	--			G	A	3				H
Z-CLA	4	--		B		G	A	3				H
Z-WEL	4	A	--			G	A	3				H
Z-WEL	4	--		B		G	A	3				H

¹⁾ Bypass diode thermal tests performed with the back sheet Tedlar or glass with the diode: SL1515A (Obsoleted) or SL1515B or SL1515E
²⁾ Bypass diode thermal tests performed with the back sheet Tedlar or glass with the diode: SL 1515A(Obsoleted)
³⁾ Bypass diode thermal tests performed with the back sheet Tedlar or glass with the diode: SL1110B or SL1515B or SL1515E
⁴⁾ Bypass diode thermal tests performed with the back sheet Tedlar with the diode: SL1110(Obsoleted) or SL 1110B or SL1515E
⁵⁾ TUV 1000 V DC for A

Annex A

Documentation Change Record

Version	Clause	Page	Change Description
A2	2.2	5	Change the industry document of DIN V-VDE V 0126 to EN50548:2011+A1:2013
	3.3	6	Add Rated impulse voltage, Rated Module working voltage, Pollution degree, TUV Rated reverse current
	3.5	8	Change the Procedure according norm of Tension and torque from DIN V-VDE V 0126-5, 5.3.21 to EN50548:2011+A1:2013, 5.3.21
	3.5	9	Change the Procedure according norm of Impulse Voltage Proof SKII and Design qualification and type approval incl. solar panel from DIN V-VDE V 0126-5, 5.3.21 to EN50548:2011+A1:2013, 5.3.21
	5	11	According to TUV requirement, add the list of product variations in TUV Rheinland certification
B	1.1	3	Remove the information for Z-SOL
	1.1	5	Update figure 5
	3.5	9	Update the type approval information
	5	12&13	Add clarification of rating information between type designations Update the table of certified type designations
C	3.4 added	6	Added table with TÜV Rheinland approved cables