Nector S Line for North American Market

DESIGN OBJECTIVES

The product described in this document has not fully been tested to ensure conformance to the requirements outlined below. TE Connectivity (TE) makes no representation or warranty, express or implied that the product will comply with these requirements. Further, TE may change these requirements based on results of additional testing and evaluation. Contact TE engineering for details.

1. SCOPE

1.1. Content

This specification covers performance, tests and quality requirements for the TE Connectivity Nector S Line intended for the North American market. The connector system is specifically designed for lighting industry applications and similar purposes from low voltage to 125 volts. The Nector S Line includes wire-to-wire configurations, wire-to-board configurations, multiple position distributor connectors, insulation displacement bus bar connectors and various accessories. The Nector S male and female contact system is based upon the Micro Quadlock contact system.

1.2. Qualification

When tests are performed on the subject product line, procedures specified in Figure 1 shall be used. All inspections shall be performed using the applicable inspection plan and product drawing.

1.3. Successful qualification testing on the subject product line was completed on TBD. The Qualification Test Report number for this testing is 501-TBD. After test validation, this documentation will be on file at and available from Engineering Practices and Standards (EPS).

2. APPLICABLE DOCUMENTS

The following documents form a part of this specification to the extent specified herein. Unless otherwise specified, the latest edition of the document applies. In the event of conflict between the requirements of this specification and the product drawing, the product drawing shall take precedence. In the event of conflict between the requirements of this specification and the referenced documents, this specification shall take precedence.

2.1. Tyco Electronics Documents

114-20131: Nector S Line Bus Bar Connector Application Specification
114-20139: Nector S Line Distributor Connector Application Specification
114-20140: Nector S Line Free Hanging Connector for SVT Cable Application Specification
114-20141: Nector S Line Free Hanging Connector for SPT-2 Cable Application Specification
108-18030: Micro Quadlock System Product Specification
501-TBD: Qualification Test Report

2.2. Industry Document

EIA-364: Electrical Connector/Socket Test Procedures Including Environmental Classifications
IEC-60529: Ingress Protection Rating
IEC 60320-1: Appliance couplers for household and similar general purposes.

2.3. Reference Document

109-197: Test Specification (Tyco Electronics Test Specifications vs EIA and IEC Test Methods)

3. REQUIREMENTS

3.1. Design and Construction

Product shall be of the design, construction and physical dimensions specified on the applicable product drawing.

3.2. Materials

Pin contact body, pin contact pin, socket body are tin-plated copper alloy. Pin contact spring and socket contact spring are stainless steel. All plastic connector components (housings, distributor covers, etc) are PBT.

3.3. Ratings

Product Type	Part Numbers	Continuous Current	Continuous Voltage	Wire/Cable Type Notes
Wire applied-crimp	293389-x Pin Contact 293387-x Outlet, 293390-x Recept. contact 293388-x Plug Housing	6.0 A	125 VAC	UL SVT or SPT-2 Cable 18AWGx2 conductor 300V 105°C.
		7.0A	42 VDC	
PCB mounted	293652 & 293653 Outlets; 293654 & 293655 Plugs	5.0A	42 VAC or VDC	N/A
		2.5A	125 VAC	
Wire applied-IDC	2213222 Bus Bar	6.0 A	125 VAC	UL SVT SPT-2 Cable 18AWGx2 conductor 300V 105°C.
		7.0A	42 VDC	
Outlet Bridge	293647-x	5.0A	42 VAC or VDC	N/A
		2.5A	125 VAC	
Plug Bridge	2213142-x	7.0A	125VAC	N/A

Operating Temperature: -40 to +110°C

3.4. Performance and Test Description

Product is designed to meet the electrical, mechanical and environmental performance requirements specified in Figure 1. Unless otherwise specified, all tests shall be performed at ambient environmental conditions.

3.5. Test Requirements and Procedures Summary

Test Description	Requirement	Procedure
Initial examination of product.	Meets requirements of product drawing and Application Specification 114-TBD.	EIA-364-18. Visual and dimensional (C of C) inspection per product drawing.
Final examination of product.	Meets visual requirements.	EIA-364-18. Visual inspection.
ELECTRICAL		
Low Level Contact Resistance (LLCR).	ΔR of 10 milliohms maximum for all connectors	EIA-364-23A. Subject mated male and female contacts to 20 millivolts open circuit at 100 milliamperes maximum. See Figure 3.
Insulation Resistance.	5 megohms minimum.	EIA-364-21C. Test at 500 Vdc for 1

		minute. Test between adjacent contacts, and between contacts connected together and the body.
Dielectric Withstanding Voltage	One minute hold with no breakdown or flashover.	EIA-364-20B, Condition I. 1250 VAC (rms) at sea level. Test between adjacent contacts of mated plug and outlet.
Temperature rise vs. current.	45°C maximum temperature rise 1.25 times rated current. (Note: For worst case condition of wire-to-board combination, test with rt angle PCB connector.)	EIA-364-70, Method 21. Stabilize at a single current level until 3 readings at 5 minute intervals are within 1°C. Connector specimens must be 100% energized.
Breaking Capacity(Mate/Un-mate with electrical load)	No permanent open circuit after test. ΔR of 10 milliohms maximum. (Note: Bridge connector ΔR of 20 milliohms maximum allowed)	IEC 60320-1, paragraph 19. Specimens energized with rated AC or DC voltage at rated current; power factor 0.75 to 0.80. Specimens subjected to 50 mating/un-mating cycles as a rated of 30 strokes per minute. Test at ambient temperature.

MECHANICAL

Vibration.	No discontinuities greater than 1 microsecond.	EIA-364-28, Test Condition VII, Level D. Subject mated plug and outlet to random vibration, 20-500 Hz, 3.10 grams, for 30 minutes in each of 3 mutually perpendicular axis. See Figure 4C.
Mechanical shock.	No discontinuities of 1 microsecond or longer duration. See Note (a).	EIA-364-27, Condition H. Subject mated plug and outlet to 30 G's half-sine shock pulses of 11 milliseconds duration. Three shocks in each direction applied along 3 mutually perpendicular planes, 18 total shocks. See Figure 4C.
Durability	See note (a)	EIA-364-9C. Subject mated plug and outlet to 10 mating and un-mating cycles at a rate 10mm/sec.
Termination Tensile Strength	No damage or separation of the conductor from the crimp is allowed.	EIA 364-8B. Pull wire at a rate of 25.4mm per minute until a force of 89N is reached, then hold for 1 minute.
Connector Mating Force.	57.0 N maximum for first mating cycle of plug and outlet. Two position connector to be tested.	EIA-364-13B. Measure force necessary to mate plug and outlet. Mate specimens at a maximum rate of 25.4 mm per minute
Connector Un-mating Force.	10.0 N minimum on 10 th un-mating cycle. Two position connector to be tested.	EIA-364-13B. Measure force to un-mate plug and outlet. Un-mate specimens at a maximum rate of 25.4 mm per minute

ENVIRONMENTAL

Thermal shock.	See Note (a)	EIA-364-32C, Test Condition VIII. Subject unmated specimens to 10 cycles between -40 and 105°C with 30 minute dwells at temperature extremes and 1 minute transition between temperatures.
Humidity/temperature cycling.	See Note (a)	EIA-364-31, Method IV. Subject unmated specimens to 10 cycles (10 days) between 25 and 65°C, 80 to 100%RH.
Temperature life.	See Note (a)	EIA-364-17B, Method A, Test Condition 3(85°C), Test Time Condition A (96 hrs.)
Solderability	Appearance of specimen shall be inspected under 10X magnification for pinholes, voids and rough surfaces. Solderable area shall have 95% minimum solder coverage.	EIA-364-56A, Procedure 3, condition 3, 260°C for 10 sec
Ingress Protection	Protection Degree = I.P. 67	IEC 60529: Immersion of samples in one meter of water for 30 minutes.

NOTE (a): *Shall meet visual requirements, show no physical damage, and meet requirements of additional tests as specified in the Product Qualification and Requalification Test Sequence shown in Figure 2.*

Figure 1 (end)

3.6. Product Qualification and Requalification Test Sequence

Test	Test Group(b)								
	1	2	3	4	5	6	7	8	9
	Test Sequence(c)								
Initial examination of product	1	1	1	1	1	1	1	1	1
LLCR	3,6,8	2,5	2,4				2,6		2,4
Insulation resistance				2,6					
Dielectric Withstanding voltage				3,7			3,5		
Temperature rise vs current						2			
Breaking capacity									3
Vibration	5								
Mechanical shock	7								
Durability	4	3							
Termination tensile strength								2	
Mating force	2								
Un-mating force	9								
Thermal shock				4					
Humidity/temperature cycling			3	5					
Temperature life		4							
Solderability					2				
Ingress Protection							4		
Final examination of product	10	6	5	8	3	3	7	3	5

NOTE (b) See paragraph 4.1.A.

(c) Numbers indicate sequence in which tests are performed.

Figure 2

4. QUALITY ASSURANCE PROVISIONS

4.1. Qualification Testing

A. Specimen Selection

Specimens shall be prepared in accordance with applicable Instruction Sheets and shall be selected at random from current production. All test groups shall consist of a minimum of 6 Nector S connectors terminated to the appropriate wire size and type.

B. Test Sequence

Qualification inspection shall be verified by testing specimens as specified in Figure 2.

4.2. Requalification Testing

If changes significantly affecting form, fit or function are made to the product or manufacturing process, product assurance shall coordinate requalification testing, consisting of all or part of the original testing sequence as determined by development/product, quality and reliability engineering.

4.3. Acceptance

Acceptance is based on verification that the product meets the requirements of Figure 1. Failures attributed to equipment, test setup or operator deficiencies shall not disqualify the product. If product failure occurs, corrective action shall be taken and specimens resubmitted for qualification. Testing to confirm corrective action is required before resubmittal.

4.4. Quality Conformance Inspection

The applicable quality inspection plan shall specify the sampling acceptable quality level to be used. Dimensional and functional requirements shall be in accordance with the applicable product drawing and this specification.

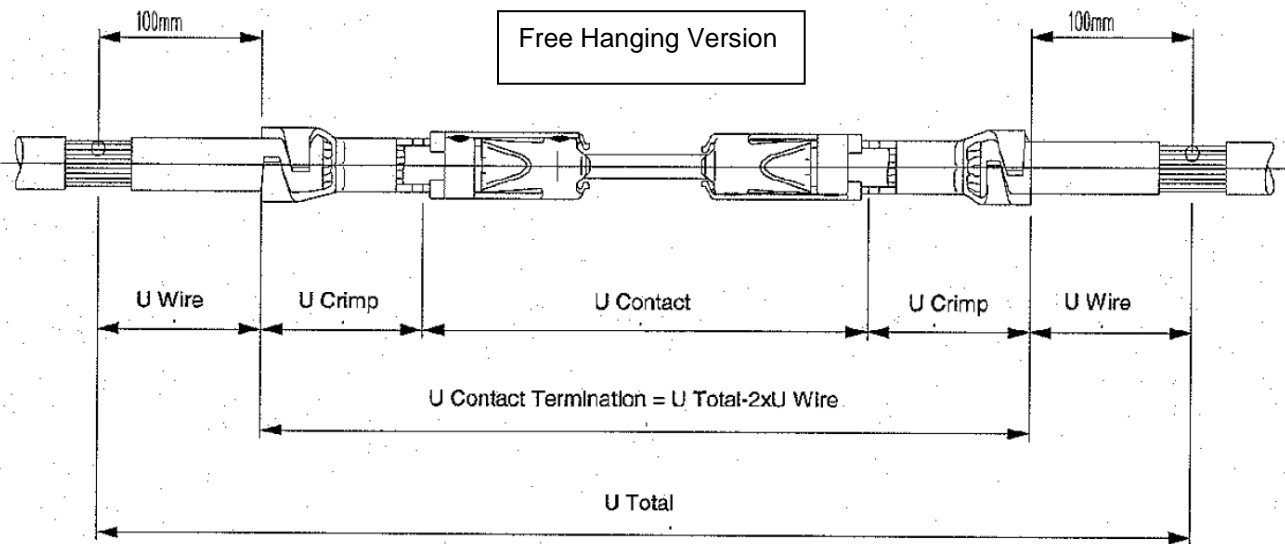

PCB MOUNTED CONNECTOR LLCR Measurement Points Figure
BUSS BAR CONNECTOR LLCR Measurement Points Figure
Figure 3
LLCR Measurement Points

- a) 2 POSITION FREE HANGING MATED OUTLET/PLUG CONNECTORS
- b) 2 POSITION PCB MOUNTED OUTLET/FREE HANGING PLUG CONECTORS

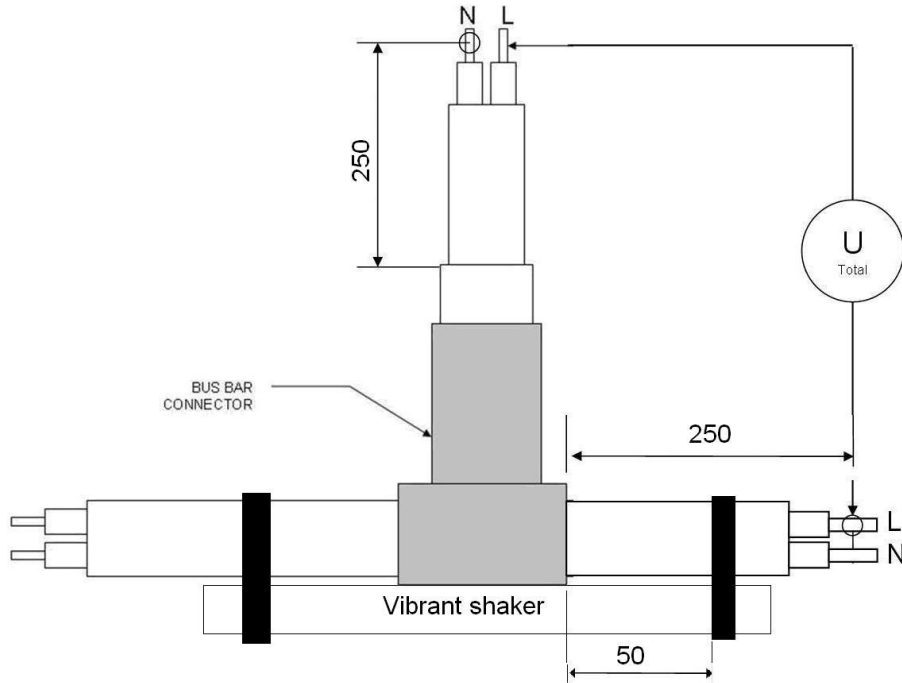

c) BUS BAR CONNECTOR

Figure 4

Vibration & Mechanical Shock Mounting Fixture

TBD

- a) 2 POSITION FREE HANGING MATED OUTLET/PLUG CONNECTORS
- b) 2 POSITION PCB MOUNTED OUTLET/FREE HANGING PLUG CONECTORS
- c) BUS BAR CONNECTOR

Figure 5

T-RISE @ RATED CURRENT