

tyco

Electronics

AMP

**Modulare Steckverbindung/
*MODULAR CONNECTOR***

**154 (60+94) polig/ *POSN.*,
wasserdicht/ *WATERPROOF***

Produktspezifikation/ *PRODUCT SPECIFICATION*

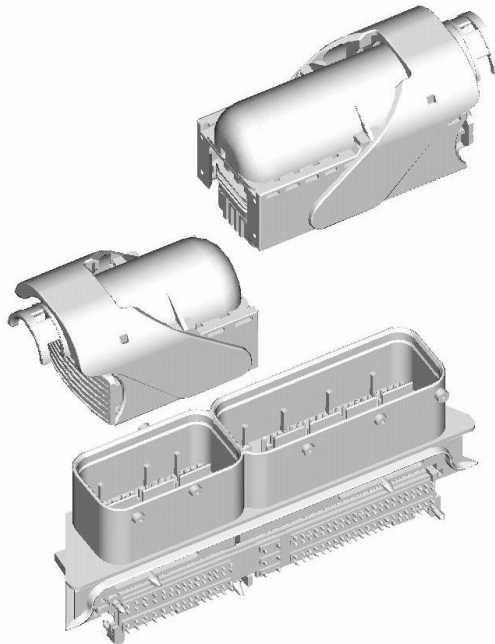

**108-18829-002
neutral / *GENERAL***

Modulare Steckverbindung 154 (60-94) polig wasserdicht

MODULAR CONNECTOR 154 (60-94) POSITION, WATERPROOF

Inhaltsverzeichnis - Deutsch -

1.	Produktübersicht.....	2
1.1.	Mitgeltende Tyco-Spezifikationen.....	3
1.2.	Stiftleiste, 154-polig.....	3
1.3.	Buchsengehäuse.....	4
1.3.1.	60-polig, Motoranschluß.....	4
1.3.2.	94-polig, Fahrzeuganschluß.....	5
1.4.	Kontakte.....	6
1.4.1.	MQS 2Punkt Clean Body.....	6
1.4.2.	MQS Clean Body (4Punkt).....	6
1.4.3.	MQS 1.5mm Clean Body.....	6
1.4.4.	AMP MCP2.8K (QKK2.8).....	7
1.4.5.	Einzeldichtung für AMP MCP2.8K Kontakt.....	7
1.5.	Wasserdichte Anwendungen.....	8
1.5.1.	Blindstopfen.....	8
1.5.2.	Dichtplatten (in Vorbereitung).....	8
2.	Leistungsdaten.....	9

CONTENT - ENGLISH -

3.	Bauraum.....	15
1.	PRODUCT OVERVIEW.....	16
1.1.	BEING VALID TYCO SPECIFICATIONS.....	17
1.2.	PIN HEADER, 154-POSN.....	17
1.3.	SOCKET HOUSING.....	18
1.3.1.	60POSN., ENGINE CONNECTION.....	18
1.3.2.	94POSN., VEHICLE CONNECTION.....	19
1.4.	CONTACTS.....	20
1.4.1.	MQS 2 POINT CLEAN BODY.....	20
1.4.2.	MQS CLEAN BODY (4POINT).....	20
1.4.3.	MQS 1.5mm CLEAN BODY.....	20
1.4.4.	AMP MCP2.8K (QKK2.8).....	21
1.4.5.	SINGLE CONDUCTOR SEAL FOR AMP MCP2.8K CONTACT.....	21
1.5.	WATERPROOFED APPLICATION.....	22
1.5.1.	SEALING PLUG.....	22
1.5.2.	SEALING PLATES (IN PREPARATION).....	22
2.	RATING DATA.....	23
3.	INSTALLATION SPACE.....	30

1. Produktübersicht

Die 154-pol. Steckverbindung dient zum Anschluß von Motorsteuergeräten sowohl im Fahrzeuginnenraum als auch an verschiedenen Verbauorten im Motorraum. Das System ist leitungsstrangseitig modular aufgebaut, so dass ein separater Motor- bzw. Fahrzeugleitungsstrang angeschlossen werden kann.

Das System besteht aus folgenden Komponenten

Benennung	Bestellnummer
Stiftleiste, 154-polig	siehe Schnittstelle 114-18304-002
Buchsengehäuse, 60-polig,	siehe Zeichnung 1534903
Buchsengehäuse, 94-polig,	siehe Zeichnung 1534904
Blindstopfen 0.63mm	1394871-1
Blindstopfen 1.5mm	1394872-1
Blindstopfen 2.8mm	828922-1
Dichtplatten, 60-polig (vorgesehen)	X-1394912-X (vorgesehen)
Dichtplatten, 94-polig (vorgesehen)	X-1394913-X (vorgesehen)
MQS ¹ 2Punkt CB ² Kontakt, DGB ³ 0.35-0.5mm ²	1534116-1
MQS CB Kontakt, DGB 0.35-0.5mm ² / 0.5-0.75mm ²	968220-X / 968221-X
MQS 1.5mm CB Kontakt, DGB 0.75-1.5mm ²	1241608-1
AMP MCP ⁴ 2.8K*, EDS ⁵ , DGB 0.5-1mm ²	1241394-1
AMP MCP2.8K, EDS, DGB >1-2.5mm ²	1241396-1
Einzeldichtung für AMP MCP2.8K	Leitung Ø2.7-Ø3.0: 963292-1 Ø2.0-Ø2.7: 963293-1 Ø1.2-Ø2.1: 963294-1

¹ Micro Quadlock System*

² Clean Body

³ Drahtgrößenbereich

⁴ Multi Contact Point*

⁵ Einzel-Dichtungs-System

1.1. Mitgeltende Tyco-Spezifikationen

114-18521-002	Verarbeitungsspezifikation Modulare Steckverbindung, 154-polig „neutral“
114-18304-002	Schnittstellenzeichnung
114-18387	Verarbeitungsspezifikation für das AMP MCP 2.8K-Kontaktsystem
114-18021	Verarbeitungsspezifikation für das MQS-Kontaktsystem
108-18717	Produktspezifikation für das AMP MCP 2.8K-Kontaktsystem
108-18874	Produktspezifikation für das MQS 2Punkt-Kontaktsystem
108-18030	Produktspezifikation für das MQS Kontaktsystem

1.2. Stiftleiste, 154-polig



Abbildung 1

Kontakte:	24 x 1.5mm x 0.63mm	6 x 2.8mm x 0.8mm
	36 x 0.63mm x 0.63mm	4 x 1.5mm x 0.63mm
		84 x 0.63mm x 0.63mm

Maßliche Definition der Schnittstelle siehe Zeichnung 114-18304-002

1.3. Buchsengehäuse

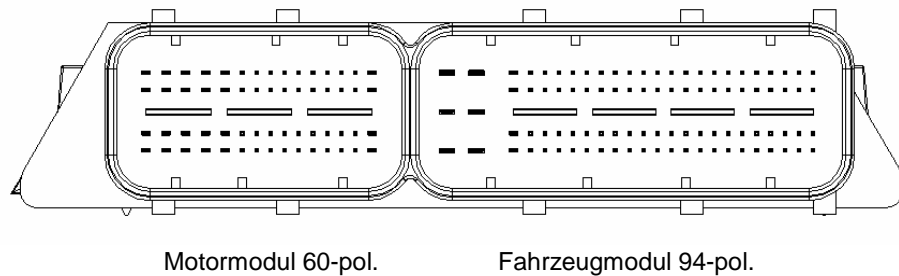
1.3.1. 60-polig, Motoranschluß

Nr.	Benennung
1	Trägergehäuse
2	Dichtung
3	Kammerblock
4	Schieber
5	Hebel
6	Kontaktgehäuse A
7	Kontaktgehäuse B
8	Sammeldichtung
9	
10	Dichtungshalter A
11	Dichtungshalter B
12	Sekundärverriegelung
13	Kappe (variabel)

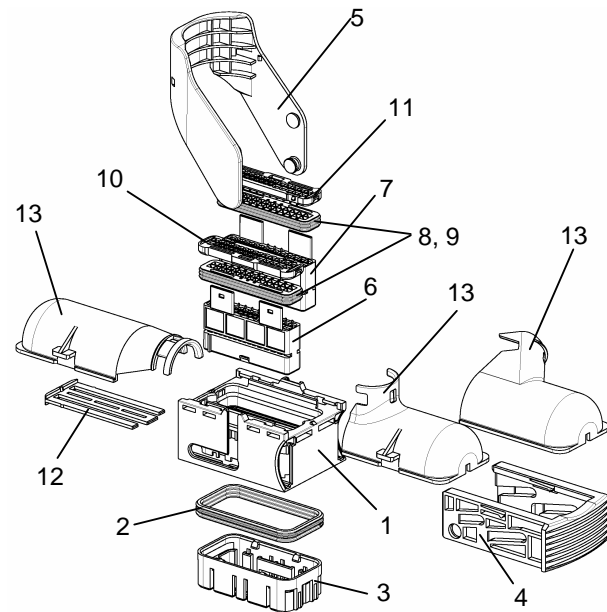

Lieferzustand siehe Zeichnung 1534903

Abbildung 2

1.3.2. 94-polig, Fahrzeuganschluß

Nr.	Benennung
1	Trägergehäuse
2	Dichtung
3	Kammerblock
4	Schieber
5	Hebel
6	Kontaktgehäuse A
7	Kontaktgehäuse B
8	Sammeldichtung
9	
10	Dichtungshalter A
11	Dichtungshalter B
12	Sekundärverriegelung
13	Sekundärverriegelung MCP
14	Kappe (variabel)



Abbildung 3

Lieferzustand siehe Zeichnung 1534904

1.4. Kontakte

1.4.1. MQS 2Punkt Clean Body

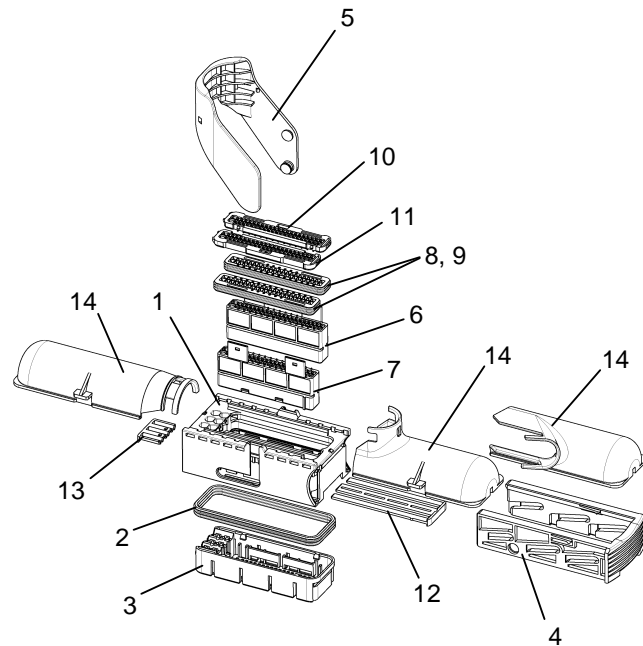
DWG	0.35 - 0.5mm ²	
Material	CuNiSi / rostfr. Stahl	
Oberfläche	Verzinkt	
Max. Steckzyklen	10	
Steckkraft	1.5-3N	
Ziehkraft	1-2N	
Übergangswiderstand	≤3mΩ	
Strombelastbarkeit (Kontakt frei in Luft, 100°C; Strombelastbarkeit im Ge- häuse siehe Pkt. 2.3.1)	Leiterquerschnitt DGB	
	0.35mm ²	0.5mm ²
	3.5A	5A
Temperaturbereich	-40°C bis +120°C	
Teil-Nr.	1534116-1	



Abbildung 4

1.4.2. MQS Clean Body (4Punkt)

Tyco AMP Teilenummer 968220-X und 968221-X; siehe Produktgruppenzeichnung 1355900

1.4.3. MQS 1.5mm Clean Body

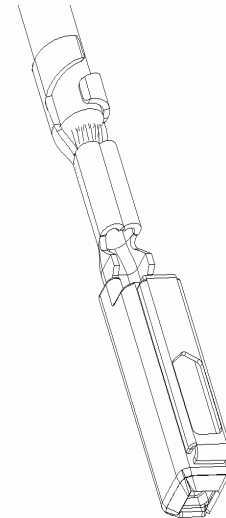
DGB	0.75 - 1.5mm ²		
Material	CuNiSi / rostfr. Stahl		
Oberfläche	Verzinkt		
Max. Steckzyklen	10		
Steckkraft	2.5-5N		
Ziehkraft	2-4N		
Übergangswiderstand	≤3mΩ		
Strombelastbarkeit (Kontakt frei in Luft, 100°C; Strombelastbarkeit im Ge- häuse siehe Pkt. 2.3.1)	Leiterquerschnitt		
	0.75mm ²	1mm ²	1.5mm ²
	7.5A	10A	15A
Temperaturbereich	-40°C bis +130°C		
Teil-Nr.	1241608-1		



Abbildung 5

1.4.4. AMP MCP2.8K (QKK2.8)

DGB	0.5 - 1mm ²	>1 - 2.5mm ²		
Material	CuNiSi / rostfr. Stahl			
Oberfläche	Verzinkt			
max. Steckzyklen	10			
Steckkraft	5-8N			
Ziehkraft	3-5N			
Übergangswiderstand	≤3mΩ			
Strombelastbarkeit (Kontakt frei in Luft, 100°C; Strombelastbarkeit im Gehäuse siehe Pkt. 2.4.1)	Leiterquerschnitt			
	0.5mm ²	1mm ²	1.5mm ²	2.5mm ²
	9A	12A	14A	17A
Temperaturbereich	-40°C bis +130°C			
Teil-Nr.	1241394-1	1241396-1		

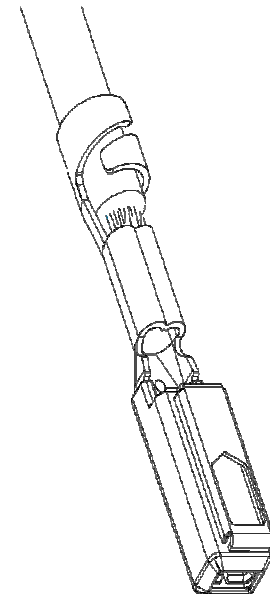

Abbildung 6



1.4.5. Einzeldichtung für AMP MCP2.8K Kontakt

Leitungsdurchmesser	z.B.: Leitungsquerschnitt bei FLR	Teil-Nr.
Ø2.7-Ø3.0	2.5mm ²	963292-1
Ø2.0-Ø2.7	1.5mm ²	963293-1
Ø1.2-Ø2.1	0.35-1mm ²	963294-1

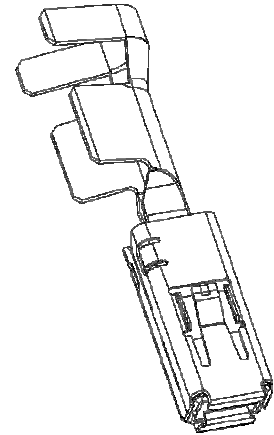
1.5. Wasserdichte Anwendungen

Freie Kammern sind bei wasserdichter Anwendung mit Blindstopfen oder Dichtplatten zu verschließen.

1.5.1. Blindstopfen

Kammergröße	0.63mm	1.5mm	2.8mm
Farbe	Schwarz	Natur (weiß)	Natur
			
Teil-Nr.	1394871-1	1394872-1	828922-1

1.5.2. Dichtplatten (in Vorbereitung)

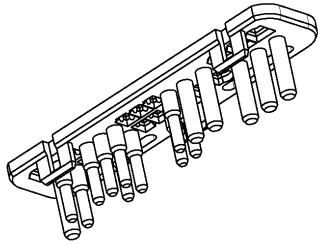
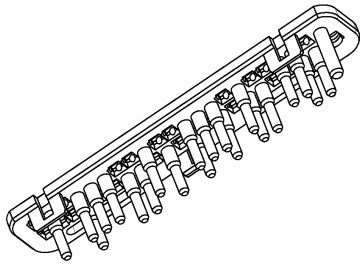
Für Buchsenstecker	60-polig	94-polig
Farbe	Schwarz	schwarz
Beispieldarstellung		
Teil-Nr.	X-1394912-X	X-1394913-X

Dichtplatten für Bestückungsvarianten haben verschiedene Bestellnummern und müssen entsprechend dem Bestückungsplan bei Tyco bestellt werden.

2. Leistungsdaten

	Prüfung	Eigenschaft
2.1.	<u>Kabelbaumstecker</u> (buchsenseitig)	
2.1.1.	Kontaktausreißkräfte aus dem Gehäuse (v = 50 mm/min)	
2.1.1.1	1. Kontaktsicherung für Signalkontakte 0,63x0,63 1,5x0,63	≥ 30N ≥ 40N
2.1.1.2	2. Kontaktsicherung für Signalkontakte 0,63x0,63 1,5x0,63	≥ 40N
2.1.1.3	1. Kontaktsicherung für Kontakte 2,8 x 0,8 mm	≥ 60N
2.1.1.4	2. Kontaktsicherung für Kontakte 2,8 x 0,8 mm	≥ 60N
2.1.2.	Steck- und Ziehkräfte (max. 10 Steckzyklen) v = 50mm/min	
2.1.2.1	ohne Schieber	< 400N
2.1.2.2	mit Schieber	< 150N
2.1.3.	<u>Falltest</u> Fallhöhe 1m auf Beton nach IEC 512-5-7b (kabelgebunden) Fallvorgänge: 2	keine Brüche / Risse
2.2.	<u>Wasserdichtigkeit</u> Kabelbaumstecker mit Messerleiste (Gesamtsystem)	
2.2.1.	Hochdruckreinigung (ähnlich Dampfstrahlprüfung gem. AK-Prüfrichtlinie PG 23) Druck: 80 – 100bar Prüfdauer je Seite: 30s Abstand Düse – Prüfling: 10 – 15 cm Temp.-Steuergerät: 90°C Temp.-Raum: 25°C Temp.-Wasser: 15°C ±5°C	Kein Wassereintritt
2.2.2.	Wasserdichtheitsprüfung gemäß AK-Prüfrichtlinie PG 23 Vor Prüfbeginn sind die Clean Body Kontakte 5-mal durch die Sammeldichtungen in das Gehäuse einzustecken und wieder ausziehen. B19.1: Temperaturschock B23.1: Dampfstrahlprüfung B23.2: Wasserbadprüfung	Kein Wassereintritt

	Prüfung	Eigenschaft																																											
2.2.3.	Dichtheitsprüfung nach DIN 40 050, Teil 9 Spritzwassertest: IP X4K (4bar) Temp·Steuergerät: 90°C Temp·Raum: 25°C Temp·Wasser: 15°C ±5°C	Kein Wassereintritt																																											
2.3.	<u>Elektrische Prüfungen</u>																																												
2.3.1.	Strombelastung (Derating) / Stromerwärmung Strombelastungsprofil (nach Ausführungsvorschrift Y 261 P06 041) <table border="1"> <thead> <tr> <th>Bereich</th> <th>ΣKontakte</th> <th>I_{eff}</th> <th>Querschnitt</th> </tr> </thead> <tbody> <tr> <td rowspan="3">Signal</td> <td>10</td> <td>2A</td> <td>0,75mm² (0,5mm²)</td> </tr> <tr> <td>10</td> <td>1A</td> <td>0,5mm²</td> </tr> <tr> <td>Rest</td> <td>0,5A</td> <td>0,35mm²</td> </tr> <tr> <td>a),b)</td> <td>6</td> <td>7A</td> <td>2,5mm²</td> </tr> <tr> <td rowspan="2">c1)</td> <td>12</td> <td>4,2A</td> <td>1,5mm²</td> </tr> <tr> <td>8</td> <td>2,5A</td> <td>0,75mm² (1,0mm²)</td> </tr> <tr> <td rowspan="3">c2)</td> <td>3</td> <td>5A</td> <td>1,5mm²</td> </tr> <tr> <td>6</td> <td>4,2A</td> <td>1,5mm²</td> </tr> <tr> <td>11</td> <td>2,5A</td> <td>0,75mm² (1,0mm²)</td> </tr> <tr> <td>d)</td> <td>4</td> <td>4A</td> <td>1,5mm²</td> </tr> <tr> <td>e)</td> <td>4</td> <td>max.</td> <td>1,5mm²</td> </tr> </tbody> </table> Umgebungstemp.: 110°C 	Bereich	ΣKontakte	I _{eff}	Querschnitt	Signal	10	2A	0,75mm ² (0,5mm ²)	10	1A	0,5mm ²	Rest	0,5A	0,35mm ²	a),b)	6	7A	2,5mm ²	c1)	12	4,2A	1,5mm ²	8	2,5A	0,75mm ² (1,0mm ²)	c2)	3	5A	1,5mm ²	6	4,2A	1,5mm ²	11	2,5A	0,75mm ² (1,0mm ²)	d)	4	4A	1,5mm ²	e)	4	max.	1,5mm ²	Stromübertemperatur <30K
Bereich	ΣKontakte	I _{eff}	Querschnitt																																										
Signal	10	2A	0,75mm ² (0,5mm ²)																																										
	10	1A	0,5mm ²																																										
	Rest	0,5A	0,35mm ²																																										
a),b)	6	7A	2,5mm ²																																										
c1)	12	4,2A	1,5mm ²																																										
	8	2,5A	0,75mm ² (1,0mm ²)																																										
c2)	3	5A	1,5mm ²																																										
	6	4,2A	1,5mm ²																																										
	11	2,5A	0,75mm ² (1,0mm ²)																																										
d)	4	4A	1,5mm ²																																										
e)	4	max.	1,5mm ²																																										
2.3.2.	Prüfsequenz: Isolationswiderstand und Spannungsfestigkeit nach klimatischer Beanspruchung (Gesamtsystem) AK-Prüfrichtlinie / 04.96, PG 20A, B 20.1 / 20.2 Lagerung bei trockener Wärme 90°C / 120h Feuchte Wärme, konstant 10 Tage, 40°C, 95% r.F. Prüflinge 0,5h ablüften auf Labortisch																																												
2.3.2.1	Isolationswiderstand: nach IEC 512, Teil 2, Prüfung 3a, Anschlußart C U = 500V (DC)	R_{iso} ≥ 100MΩ																																											
2.3.2.2	Spannungsfestigkeit: nach IEC 512, Teil 2, Prüfung 4a, Anschlußart C U = 500V ~ / 60s	Kein Durchschlag bzw. Überschlag																																											

	Prüfung	Eigenschaft
2.3.3.	Kriech- und Luftstrecken Bestimmung der kritischen Luft- und Kriechstrecken auf Zeichnungsbasis	Dokumentation der Ergebnisse
2.3.4.	Abbildung Feuchtigkeitseintrag durch Temperaturwechsel	
2.3.4.1	Aufbau 1: Kontaktgehäuse: 1h Kälte, $t_u = -20^{\circ}\text{C}$ Gerät: 1 h Wärme, $t_o = +40^{\circ}\text{C}$ bei 90% rel. Luftfeuchte Kontaktgehäuse sofort nach Entnahme aus Kälte auf Gerät stecken. Kontaktgehäuse und Gerät, gesteckt, $t_o = +40^{\circ}\text{C}$ bei 90% rel. Luftfeuchte, Lagerdauer 1h. Unverzögliche Bestromung benachbarter 1.5mm Kontakte außerhalb des Klimaschranks. Prüfspannung: 1kV (anschließend erhöhen bis Überschlag) Prüfdauer: 3min	kein Überschlag
2.3.4.2	Aufbau 2: Kontaktgehäuse: 1h Kälte, $t_u = -20^{\circ}\text{C}$ Gerät: 1h Wärme, $t_o = +40^{\circ}\text{C}$ bei 90% rel. Luftfeuchte Kontaktgehäuse sofort nach Entnahme aus Kälte auf Gerät stecken. Kontaktgehäuse und Gerät, gesteckt, $t_o = +80^{\circ}\text{C}$ bei 90% rel. Luftfeuchte, Lagerdauer 1h. Bestromung benachbarter 1.5mm Kontakte außerhalb des Klimaschranks. (Umlagerungszeit max. 1min.) Prüfspannung: 1kV (anschließend erhöhen bis Überschlag) Prüfdauer: 3min	kein Überschlag
2.3.4.3	Aufbau 3: Kontaktgehäuse und Gerät, nicht gesteckt, $t_o = 80^{\circ}\text{C}$ bei 98% rel. Luftfeuchte, Lagerdauer 10h. Kontaktgehäuse und Gerät, nicht gesteckt: 1h Kälte, $t_u = -40^{\circ}\text{C}$ Kontaktgehäuse ohne Entnahme aus Klimakammer stecken. Unverzögliche Bestromung benachbarter 1.5mm Kontakte außerhalb des Klimaschranks. Prüfspannung: 1kV (anschließend erhöhen bis Überschlag) Prüfdauer: 3min	kein Überschlag

	Prüfung	Eigenschaft
2.4.	<u>Temperaturbeständigkeit (Gesamtsystem)</u>	
2.4.1.	<p>Temperaturwechsel / Schock Für die gesamte Prüfsequenz sind dieselben Teile zu verwenden. Temperaturlagerung nach DIN/IEC 68-2-2 Temperatur: +110°C Prüfdauer: 48h anschließend Temperaturschockprüfung nach DIN/EC 68-2-14 Na Temperaturbereich: -40°C...+110°C Haltezeit: ≥ 45min (Zyklusdauer 1,5h) Umlagerungszeit: ≥ 10s Zyklenzahl: 500 anschließend Feuchteprüfung nach AK-Prüfrichtlinie PG 19-B 19.5</p>	<p>keine Rißbildung keine Materialversprödung Einhaltung der Werte für: - Isolationswiderstand - Leckratenprüfung - Kontaktausdrückkräfte (Messerleiste)</p>
2.5.	<u>Vibrationsbeständigkeit</u> Prüfung mit vorgealterten Teilen	
2.5.1.	<p>Voralterung: 110°C / 48h -40°C / +110°C je 30min, 50 Zyklen</p>	<p>Optische Kontrolle auf Risse/Veränd. RD_{ges} ≤ 10mΩ</p>

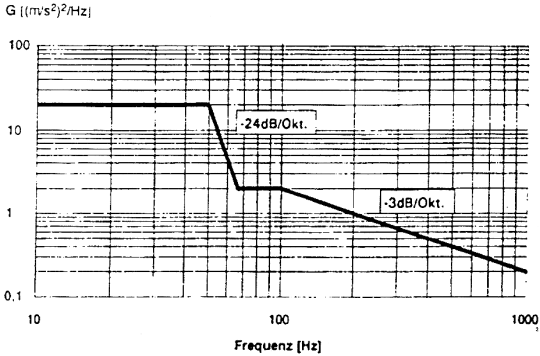
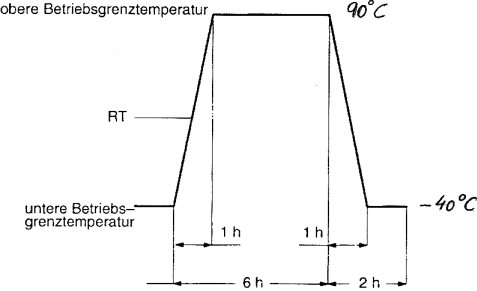
	Prüfung	Eigenschaft
<p>2.5.2.</p>	<p>Breitbandrauschprüfung nach VW 801 01 / 1999-06, Pkt. 8.2 / Schärfegr. 1 (Tab. 7) mit überlag. Temperaturwechsel Frequenz: 10-1000Hz Effektivwert der Beschleunigung: 3,81g Prüfung in den 3 Hauptebenen Schwingdauer je Ebene: 8h (Jeder Prüfling ist in allen Haupttraumachsen zu prüfen)</p>  <p>Temperaturwechsel nach VW 801 01, Pkt. 10.3, Temperaturprofil nach Bild 6.</p> 	<p>Optische Kontrolle auf Risse/Veränd.</p> <p>R_D vor/nach dem Test RD_{ges} ≤ 10mΩ</p> <p>Überwachung auf unzuläss. Kontaktunterbrechung > 1 μs (100mA, R_{Schwell} = 25Ω)</p> <p>Abtastrate: 20ns Oberflächenunters.: kein flächenhafter Durchrieb (Bildokumentation)</p>
<p>2.6.</p>	<p><u>Chemische Beständigkeit</u> Prüfung gemäß AK-Prüfrichtlinie PG 22 B, erweiterte Prüfung, 4 Zyklen (inkl. Prüfung mit Batteriesäure)</p>	<p>Die Prüflinge dürfen keine funktionell bedeutsamen dimensionellen und strukturellen Veränderungen aufweisen</p>
<p>2.7.</p>	<p><u>Langzeitprüfung (Verschleißfestigkeit)</u> Voralterung: 85°C / 48h -40°C / +85°C je 30min, 100 Zyklen Umlagerungszeit < 10s</p>	

	Prüfung	Eigenschaft																				
2.7.1.	<p>Breitbandrauschprüfung 224h</p> <table border="1"> <thead> <tr> <th>Frequenz (Hz)</th> <th>G (m/s²)²/Hz der Beschleunigung</th> <th>Effektivwert</th> <th>Testdauer</th> </tr> </thead> <tbody> <tr> <td>10</td> <td>4,84</td> <td rowspan="3">14m/s²</td> <td rowspan="3">200h</td> </tr> <tr> <td>300</td> <td>0,163</td> </tr> <tr> <td>1000</td> <td>0,0148</td> </tr> <tr> <td>10</td> <td>9,68</td> <td rowspan="3">20m/s²</td> <td rowspan="3">24 h</td> </tr> <tr> <td>300</td> <td>0,326</td> </tr> <tr> <td>1000</td> <td>0,0296</td> </tr> </tbody> </table> <p>Eine Steckverbindung wird nur in einer Raumrichtung geschüttelt.</p> <p>Vibrationsprüfung erfolgt ohne Temp.-Überlagerung.</p> <p>Die Leitungsquerschnittsaufteilung erfolgt linear über die Anzahl der Kontakte im jeweiligen Modul.</p>	Frequenz (Hz)	G (m/s ²) ² /Hz der Beschleunigung	Effektivwert	Testdauer	10	4,84	14m/s ²	200h	300	0,163	1000	0,0148	10	9,68	20m/s ²	24 h	300	0,326	1000	0,0296	<p>Optische Kontrolle auf Risse/Veränd.</p> <p>R_D vor/nach dem Test RD_{ges} ≤ 10mΩ</p> <p>Überwachung auf unzuläss. Kontaktunterbrechung > 1μs (100mA, R_{Schwell} = 25Ω) Abtastrate: 20ns</p> <p>Oberflächenunters. kein flächenhafter Durchrieb (Bildokumentation)</p>
Frequenz (Hz)	G (m/s ²) ² /Hz der Beschleunigung	Effektivwert	Testdauer																			
10	4,84	14m/s ²	200h																			
300	0,163																					
1000	0,0148																					
10	9,68	20m/s ²	24 h																			
300	0,326																					
1000	0,0296																					

3. Bauraum



Abbildung 7

1. PRODUCT OVERVIEW

THE 154-POSN. PLUG-TYPE CONNECTOR IS USED FOR THE CONNECTION OF ENGINE CONTROL UNITS INSIDE THE VEHICLE AND ALSO AT VARIOUS INSTALLATIONS IN THE ENGINE COMPARTEMENT. ON THE CABLE SIDE, THE SYSTEM HAS A MODULAR DESIGN, PERMITTING THE CONNECTION OF A SEPARATE ENGINE AND/ OR VEHICLE CABLE HARNESS.

THE SYSTEM CONSISTS OF THE FOLLOWING COMPONENTS:

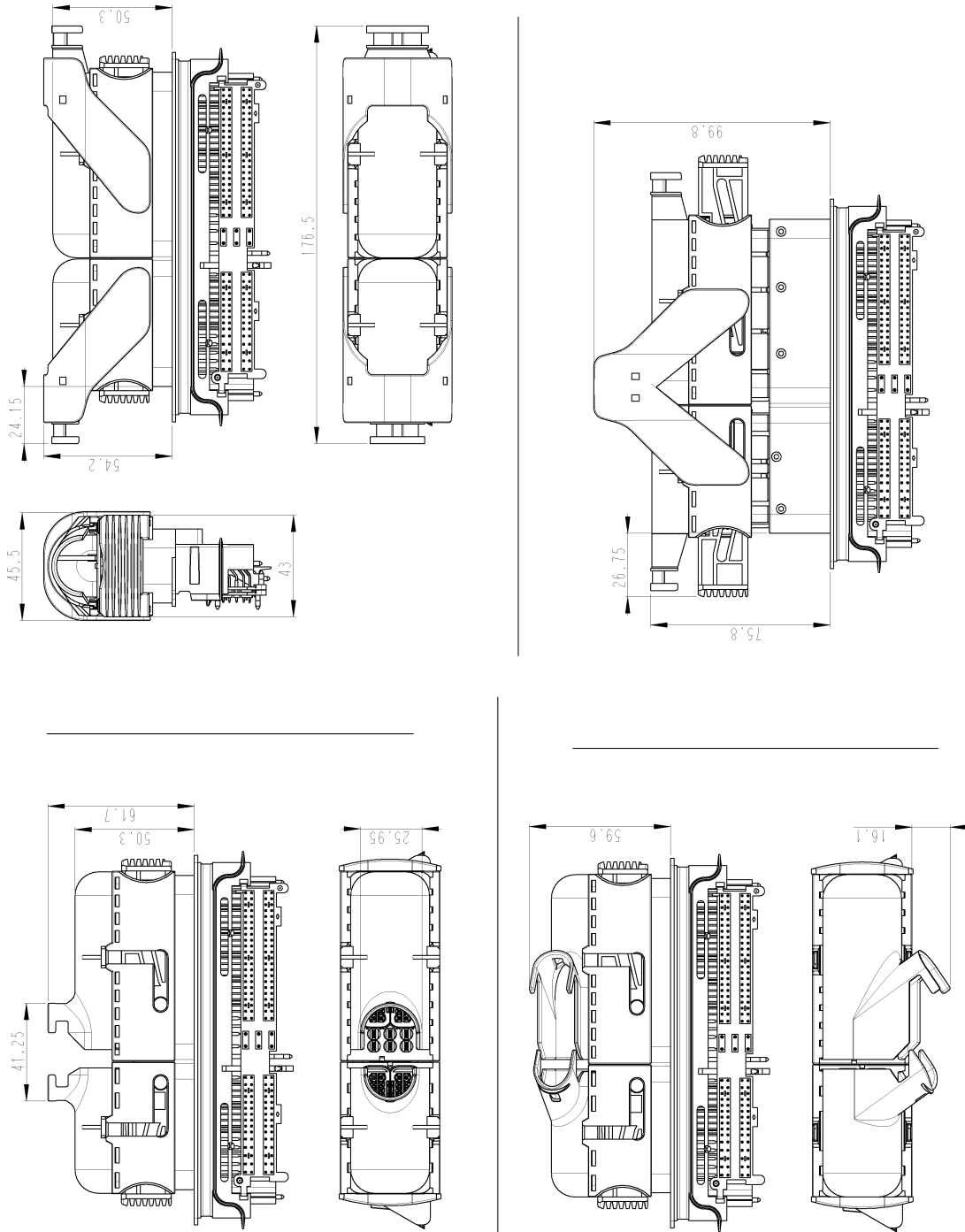
DESIGNATION	PARTNUMBER
MALE CONNECTOR, 154-POSN.	SEE INTERFACE 114-18304-002
SOCKET HOUSING, 60-POSN.	SEE DRAWING 1534903
SOCKET HOUSING, 94-POSN.	SEE DRAWING 1534904
SEALING PLUG 0.63mm	1394871-1
SEALING PLUG 1.5mm	1394872-1
SEALING PLUG 2.8mm	828922-1
SEALING PLATE, 60-POSN. (PROVIDED)	X-1394912-X (PROVIDED)
SEALING PLATE, 94-POSN. (PROVIDED)	X-1394913-X (PROVIDED)
MQS ⁶ 2 POINT CB ⁷ CONTACT, WSR ⁸ 0.35-0.5mm ²	1534116-1
MQS CB CONTACT, WSR 0.35-0.5mm ² / 0.5-0.75mm ²	968220-X / 968221-X
MQS 1.5mm CB CONTACT, WSR 0.75-1.5mm ²	1241608-1
AMP MCP ⁹ 2.8K*, SWS ¹⁰ , WSR 0.5-1mm ²	1241394-1
AMP MCP2.8K, SWS, WSR >1-2.5mm ²	1241396-1
SINGLE-CONDUCTOR SEAL FOR AMP MCP2.8K	Leitung Ø2.7-Ø3.0: 963292-1 Ø2.0-Ø2.7: 963293-1 Ø1.2-Ø2.1: 963294-1

¹ Micro Quadlock System*

² Clean Body

³ Wire Size Range

⁴ Multi Contact Point*

⁵ Single Wire Seal

1.1. BEING VALID TYCO SPECIFICATIONS

114-18521-002	Application Specification for the modular connector, 154posn "general"
114-18304-002	Interface drawing
114-18387	Application Specification for the AMP MCP 2.8K contact system
114-18021	Application Specification for the MQS contact system
108-18717	Product Specification for the AMP MCP 2.8K contact system
108-18874	Product Specification for the MQS 2point contact system
108-18030	Product Specification for the MQS contact system

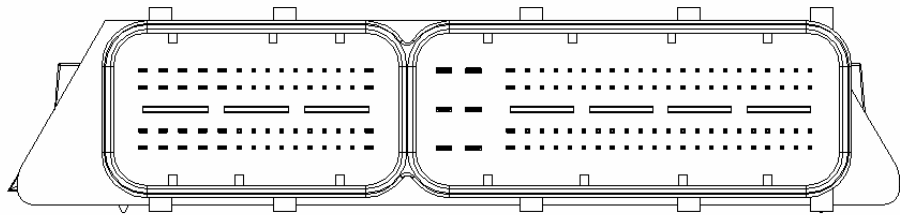
1.2. PIN HEADER, 154-POSN.

ENGINE MODULE 60POSN. VEHICLE MODULE 94POSN.

FIGURE 8

CONTACTS:	24 x 1.5mm x 0.63mm	6 x 2.8mm x 0.8mm
	36 x 0.63mm x 0.63mm	4 x 1.5mm x 0.63mm
		84 x 0.63mm x 0.63mm

FOR THE DIMENSIONAL DEFINITION OF THE INTERFACE SEE DRAWING 114-18304-002

1.3. SOCKET HOUSING

1.3.1. 60POSN., ENGINE CONNECTION

Nr.	DESIGNATION
1	SUPPORT HOUSING
2	SEAL
3	CHAMBER BLOCK
4	SLIDE
5	LEVER
6	CONTACT HOUSING A
7	CONTACT HOUSING B
8	COLLECTIVE SEAL
9	
10	SEAL HOLDER A
11	SEAL HOLDER B
12	SECONDARY INTERLOCK
13	CAP (VARIABLE)

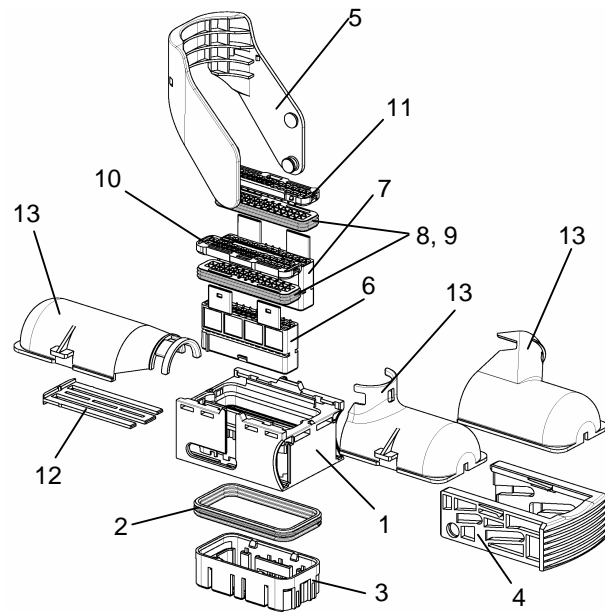

DELIVERY STATE SEE DRAWING 1534903

FIGURE 9

1.3.2. 94POSN., VEHICLE CONNECTION

Nr.	DESIGNATION
1	SUPPORT HOUSING
2	SEAL
3	CHAMBER BLOCK
4	SLIDE
5	LEVER
6	CONTACT HOUSING A
7	CONTACT HOUSING B
8	COLLECTIVE SEAL
9	
10	SEAL HOLDER A
11	SEAL HOLDER B
12	SECONDARY LOCK
13	SECONDARY LOCK MCP
14	CAP (VARIABLE)

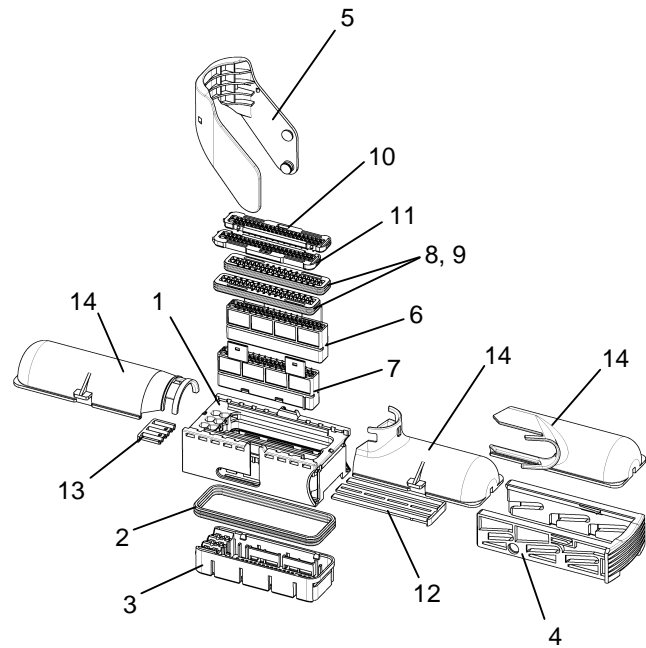

FIGURE 10

DELIVERY STATE SEE DRAWING 1534904

1.4. CONTACTS

1.4.1. MQS 2 POINT CLEAN BODY

WSR	0.35 - 0.5mm ²	
MATERIAL	CuNiSi / STAINLESS STEEL	
SURFACE FINNISH	TINNED	
MAX. INSERTION CYCLES	10	
MATING FORCE	1.5-3N	
UNMATING FORCE	1-2N	
CONTACT RESISTANT	≤3mΩ	
CURRENT CARRYING CAPACITY (CONTACT FREE IN AIR, 100°C; CURRENT CARRYING CAPACITY IN HOUSING: SEE SECTION 2.3.1)	WIRE CROSS SECTION, DGB	
	0.35mm ²	0.5mm ²
	3.5A	5A
TEMPERATURE RANGE	-40°C TO +120°C	
PART NO.	1534116-1	

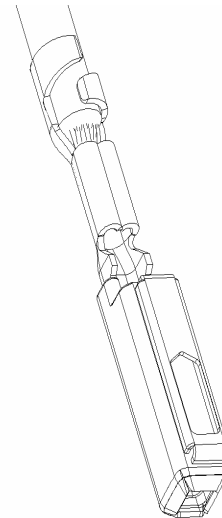

FIGURE 11

1.4.2. MQS CLEAN BODY (4POINT)

Tyco AMP part numbers 968220-X and 968221-X; see product group drawing 1355900.

1.4.3. MQS 1.5mm CLEAN BODY

WSR	0.75 - 1.5mm ²		
MATERIAL	CuNiSi / STAINLESS STEEL		
SURFACE FINNISH	TINNED		
MAX. INSERTION CYCLES	10		
MATING FORCE	2.5-5N		
UNMATING FORCE	2-4N		
CONTACT RESISTANT	≤3mΩ		
CURRENT CARRYING CAPACITY (CONTACT FREE IN AIR, 100°C; CURRENT CARRYING CAPACITY IN HOUSING: SEE SECTION 2.3.1)	WIRE CROSS SECTION, DGB		
	0.75mm ²	1mm ²	1.5mm ²
	7.5A	10A	15A
TEMPERATURE RANGE	-40°C TO +130°C		
PART NO	1241608-1		

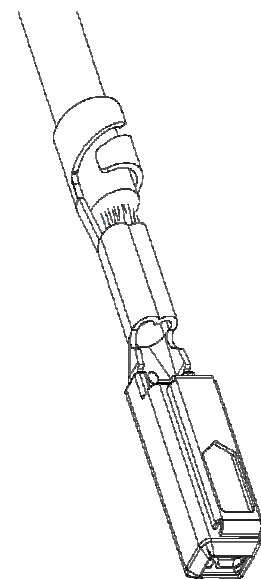

FIGURE 12

1.4.4. AMP MCP2.8K (QKK2.8)

WSR	0.5 - .1mm ²	>1 - 2.5mm ²		
MATERIAL	CuNiSi / STAINLESS STEEL			
SURFACE FINNISH	TINNED			
MAX. INSERTION CYCLES	10			
MATING FORCE	5-8N			
UNMATING FORCE	3-5N			
CONTACT RESISTANT	≤3mΩ			
CURRENT CARRYING CAPACITY (CONTACT FREE IN AIR, 100°C; CURRENT CARRYING CAPACITY IN HOUSING: SEE SECTION 2.3.1)	WIRE CROSS SECTION, DGB			
	0.5mm ²	1mm ²	1.5mm ²	2.5mm ²
	9A	12A	14A	17A
TEMPERATURE RANGE	-40°C TO +130°C			
PART NO	1241394-1	1241396-1		

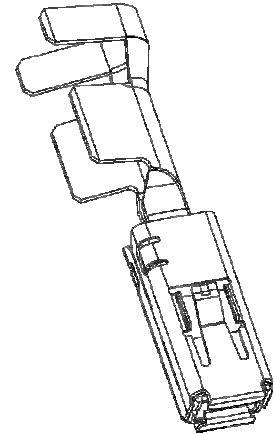

FIGURE 13



1.4.5. SINGLE CONDUCTOR SEAL FOR AMP MCP2.8K CONTACT

WIRE DIAMETER	FOR EXAMPLE: WIRE CROSS SECTION OF FLR	PART-NO.
Ø2.7-Ø3.0	2.5mm ²	963292-1
Ø2.0-Ø2.7	1.5mm ²	963293-1
Ø1.2-Ø2.1	0.35-1mm ²	963294-1

1.5. WATERPROOFED APPLICATION

IN A WATERPROOFED APPLICATION FREE CHAMBERS MUST BE SEALED WITH A SEALING PLUG OR A SEALING PLATE.

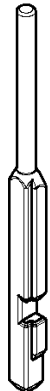
1.5.1. SEALING PLUG

CHAMBERSIZE	0.63mm	1.5mm	2.8mm
COULOR	BLACK	NATUR (WHITE)	NATUR
			
PART-NO.	1394871-1	1394872-1	828922-1

1.5.2. SEALING PLATES (IN PREPARATION)

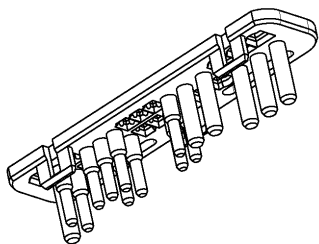
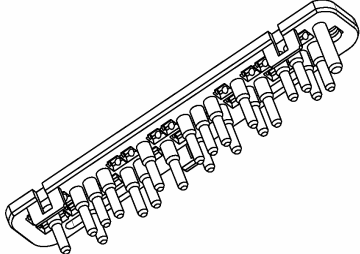
FOR SOCKET HOUSING	60-PIN	94-PIN
COULOR	BLACK	BLACK
REPRESENTATION OF AN EXAMPLE		
PART-NO.	X-1394912-X	X-1394913-X

SEALING PLATES FOR VARIABLE LOADED CHAMBERS HAVE DIFFERENT ORDER NUMBERS UND MUST BE ORDERED FROM TYCO ACCORDING TO THE LOADING PLAN.

2. RATING DATA

	TEST	REQUIREMENT
2.1.	<u>CABLE-HARNESS CONNECTOR (FEMALE SIDE)</u>	
2.1.1.	CONTACT PULL-OUT FORCES (v = 50 mm/min)	
2.1.1.1	1 st LOCKING FOR SIGNAL CONTACTS 0,63x0,63 1,50x0,63	≥ 30N ≥ 40N
2.1.1.2	2 nd LOCKING FOR SIGNAL CONTACTS 0,63x0,63 1,50x0,63	≥ 40N
2.1.1.3	1 st LOCKING RETAINER FOR CONTACTS 2,8 x 0,8 mm	≥ 60N
2.1.1.4	2 nd LOCKING RETAINER FOR CONTACTS 2,8 x 0,8 mm	≥ 60N
2.1.2.	MATING AND UNMATING FORCES (MAX. 10 INSERTIONS) v = 50mm/min	
2.1.2.1	WITHOUT SLIDE	< 400N
2.1.2.2	WITH SLIDE	< 150N
2.1.3.	<u>DROP TEST</u> DROPPED 1m ONTO CONCRETE ACC.TO IEC 512-5-7b (CABLE CONNECTED) DROPS: 2	NO BREAKAGE/ CRACKS
2.2.	<u>WATERPROOFNESS</u> CABLE-HARNESS CONNECTOR WITH HEADER (COMPLETE SYSTEM)	
2.2.1.	HIGH-PRESSURE WASHING (SIMILAR TO STEAM-JET TEST ACC. TO AK-TEST GUIDELINE PG 23) PRESSURE: 80 – 100bar TEST DURATION PER SIDE 30s DISTANCE NOZZLE-TEST OBJECT: 10 – 15 cm TEMP.CONTROL UNIT. 90°C TEMP.ROOM. 25°C TEMP.WATER. 15°C ±5°C	NO ENTRY OF WATER

	TEST	REQUIREMENT
2.2.2.	WATERPROOFNESS TEST ACC. TO AK-TEST GUIDELINE PG 23 BEFORE THE TEST, INSERT THE CLEAN BODY CONTACTS 5 TIMES THROUGH THE COLLECTIVE SEALS INTO THE HOUSING AND REMOVE THEM AGAIN. B19.1: TEMPERATURE SHOCK B23.1: STEAM JET TEST B23.2: WATER BATH TEST	NO ENTRY OF WATER
2.2.3.	WATERPROOFNESS TEST ACC. TO DIN 40 050, PART 9 SPLASH-WATER-TEST: IP X4K (4bar) TEMP.CONTROL UNIT: 90°C TEMP.ROOM: 25°C TEMP.WATER: 15°C ±5°C	NO ENTRY OF WATER

	TEST	REQUIREMENT																																																
2.3.	<u>ELECTRICAL TESTS</u>																																																	
2.3.1.	<p>CURRENT CARRYING CAPACITY (DERATING) / CURRENT HEATING CURRENT LOAD PROFILE (ACC. TO EXECUTION SPECIFICATION Y 261 P06 041)</p> <table border="1"> <thead> <tr> <th>RANGE</th> <th>Σ CONTACTS</th> <th>I_{eff}</th> <th>CROSS-SECTION</th> </tr> </thead> <tbody> <tr> <td>SIGNAL</td> <td>10</td> <td>2A</td> <td>0,75mm² (0,5mm²)</td> </tr> <tr> <td></td> <td>10</td> <td>1A</td> <td>0,5mm²</td> </tr> <tr> <td></td> <td>REST</td> <td>0,5A</td> <td>0,35mm²</td> </tr> <tr> <td>a),b)</td> <td>6</td> <td>7A</td> <td>2,5mm²</td> </tr> <tr> <td>c1)</td> <td>12</td> <td>4,2A</td> <td>1,5mm²</td> </tr> <tr> <td></td> <td>8</td> <td>2,5A</td> <td>0,75mm² (1,0mm²)</td> </tr> <tr> <td>c2)</td> <td>3</td> <td>5A</td> <td>1,5mm²</td> </tr> <tr> <td></td> <td>6</td> <td>4,2A</td> <td>1,5mm²</td> </tr> <tr> <td></td> <td>11</td> <td>2,5A</td> <td>0,75mm² (1,0mm²)</td> </tr> <tr> <td>d)</td> <td>4</td> <td>4A</td> <td>1,5mm²</td> </tr> <tr> <td>e)</td> <td>4</td> <td>max.</td> <td>1,5mm²</td> </tr> </tbody> </table> <p>AMBIENT TEMPERATURE.: 110°C</p>	RANGE	Σ CONTACTS	I _{eff}	CROSS-SECTION	SIGNAL	10	2A	0,75mm ² (0,5mm ²)		10	1A	0,5mm ²		REST	0,5A	0,35mm ²	a),b)	6	7A	2,5mm ²	c1)	12	4,2A	1,5mm ²		8	2,5A	0,75mm ² (1,0mm ²)	c2)	3	5A	1,5mm ²		6	4,2A	1,5mm ²		11	2,5A	0,75mm ² (1,0mm ²)	d)	4	4A	1,5mm ²	e)	4	max.	1,5mm ²	TEMPERATURE RISE DUE TO CURRENT <30K
RANGE	Σ CONTACTS	I _{eff}	CROSS-SECTION																																															
SIGNAL	10	2A	0,75mm ² (0,5mm ²)																																															
	10	1A	0,5mm ²																																															
	REST	0,5A	0,35mm ²																																															
a),b)	6	7A	2,5mm ²																																															
c1)	12	4,2A	1,5mm ²																																															
	8	2,5A	0,75mm ² (1,0mm ²)																																															
c2)	3	5A	1,5mm ²																																															
	6	4,2A	1,5mm ²																																															
	11	2,5A	0,75mm ² (1,0mm ²)																																															
d)	4	4A	1,5mm ²																																															
e)	4	max.	1,5mm ²																																															
2.3.2.	<p>TEST SEQUENCE: INSULATION RESISTANCE AND VOLTAGE BREAKDOWN STRENGTH AFTER CLIMATIC STRESS (COMPLETE SYSTEM) AK-TEST GUIDELINE / 04.96, PG 20A, B 20.1 / 20.2 STORAGE IN DRY HEAT 90°C / 120h MOIST HEAT; KONSTANT 10 DAYS, 40°C, 95% RELATIVE HUMIDITY. ALLOW SAMPLES TO COOL FOR 0,5h ON LABORATORY BENCH</p>																																																	
2.3.2.1	<p>INSULATION RESISTANCE: ACC. TO IEC 512, PART 2, TEST 3a, CONNECTION TYPE C U = 500V (DC)</p>	R _{iso} ≥ 100MΩ																																																
2.3.2.2	<p>VOLTAGE BREAKDOWN STRENGTH: ACC. TO IEC 512, PART 2, TEST 4a, CONNECTION TYPE C U = 500V ~ / 60s</p>	NO PUNCH OR ELECTRICAL BLOW																																																
2.3.3.	<p>CREEPING DISTANCE AND AIR PATH: DETERMINATION OF THE CRITICAL AIR AND CREEPING PATH IS BASED ON THE DRAWINGS</p>	DOCUMENTATION OF RESULTS																																																

	TEST	REQUIREMENT
2.3.4.	FIGURE MOISTURE ENTRY DUE TO TEMPERATURE CHANGES	
2.3.4.1	<p>TEST SET-UP 1: CONTACT HOUSING: 1h COLDNESS, $t_u = -20^{\circ}\text{C}$ UNIT: 1 h WARMNESS, $t_o = +40^{\circ}\text{C}$ AT 90% REL. HUMIDITY PLUG CONTACT HOUSING INTO UNIT IMMEDIATELY AFTER REMOVAL FROM COLD STORAGE.</p> <p>CONTACT HOUSING AND UNIT, CONNECTED, $t_o = +40^{\circ}\text{C}$ AT 90% REL. HUMIDITY, STORAGE DURATION 1h. IMMEDIATE APPLICATION OF CURRENT TO NEIGHBOURING 1,5 mm CONTACTS OUTSIDE CLIMATE CABINET. TEST VOLTAGE: 1kV (THEN INCREASE UNTIL ELECTRIC BLOW)</p> <p>TEST DURATION: 3min</p>	NO ARCING
2.3.4.2	<p>TEST SET-UP 2: CONTACT HOUSING: 1h COLDNESS, $t_u = -20^{\circ}\text{C}$ UNIT: 1 h WARMNESS, $t_o = +40^{\circ}\text{C}$ AT 90% REL. HUMIDITY PLUG CONTACT HOUSING INTO UNIT IMMEDIATELY AFTER REMOVAL FROM COLD STORAGE.</p> <p>CONTACT HOUSING AND UNIT, CONNECTED, $t_o = +80^{\circ}\text{C}$ AT 90% REL. HUMIDITY, STORAGE DURATION 1h. IMMEDIATE APPLICATION OF CURRENT TO NEIGHBOURING 1,5 mm CONTACTS OUTSIDE CLIMATE CABINET. (MAX. TRANSFER TIME 1min.) TEST VOLTAGE: 1kV (THEN INCREASE UNTIL ELECTRIC BLOW)</p> <p>TEST DURATION: 3min</p>	NO ARCING
2.3.4.3	<p>TEST SET-UP 3: CONTACT HOUSING AND UNIT, NOT CONNECTED, $t_o = 80^{\circ}\text{C}$ AT 98 REL. HUMIDITY, STORAGE DURATION 10h. CONTACT HOUSING AND UNIT; NOT CONNECTED: 1h COLD, $t_u = -40^{\circ}\text{C}$</p> <p>PLUG IN CONTACT HOUSING WITHOUT REMOVING FROM THE CLIMATE CHAMBER. IMMEDIATE APPLICATION OF CURRENT TO NEIGHBOURING 1,5 mm CONTACTS OUTSIDE CLIMATE CABINET. TEST VOLTAGE: 1kV (THEN INCREASE UNTIL ELECTRIC BLOW)</p> <p>TEST DURATION: 3min</p>	NO ARCING

	TEST	REQUIREMENT
2.4.	<u>TEMPERATURE RESISTANCE (COMPLETE SYSTEM)</u>	
2.4.1.	<p>TEMPERATURE CHANGE/ SHOCK USE THE SAME SAMPLE FOR THE ENTIRE TEST SEQUENCE. TEMPERATURE STORAGE ACC. TO DIN/IEC 68-2-2 TEMPERATURE: +110°C TEST DURATION: 48h THEN TEMPERATUR SHOCK TEST ACC. TO DIN/EC 68-2-14 Na TEMPERATUR RANGE: -40°C...+110°C HOLD TIME: ≥ 45min (CYCLE LENGTH 1,5h) TRANSFER TIME: ≥ 10s NUMBER OF CYCLES: 500 THEN MOISTURE TEST ACC.TO AK-TEST GUIDELINE PG19-B19.5</p>	<p>NO CRACKING NO EMBRITTLEMENT OF MATERIAL COMPLIANCE WITH VALUES FOR: - INSULATION RESISTANCE - LECKAGE-RATE TEST - CONTACT EXTRACTION FORCE (TAB HEADER)</p>
2.5.	<u>VIBRATION RESISTANCE</u> TEST WITH PRE AGED SAMPLES	
2.5.1.	<p>PRE AGEING: 110°C / 48h -40°C / +110°C je 30min, 50 CYCLES</p>	<p>VISUAL INSPECTION FOR CRACKS OR CHANGES $R_{D_{ges}}$ $\leq 10m\Omega$</p>

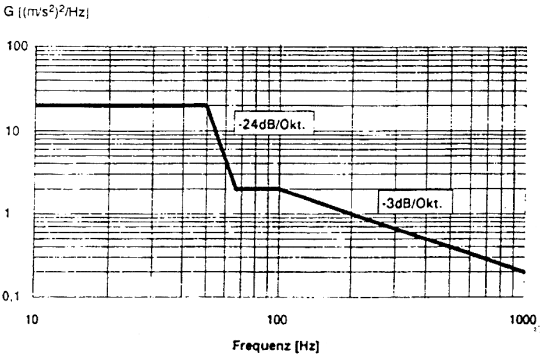
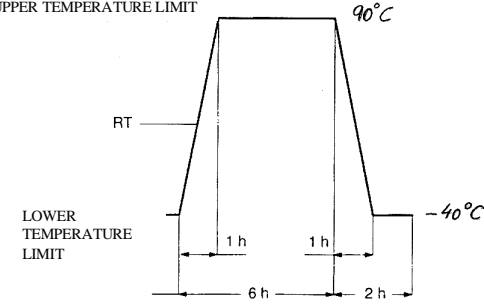
	TEST	REQUIREMENT
<p>2.5.2.</p>	<p>WIDEBAND NOISE TEST ACC.TO VW 801 01/1999-06, SECTION 8.2/ STRINGENCY (TABLE 7) WITH SUPERIMPOSED TEMERATURE CHANGE FREQUENCY: 10-1000Hz RMS VALUE OF ACCELERATION: 3,81g TEST IN ALL 3 MAJOR LAYER VIBRATION DURATION PER LAYER: 8h (TEST EACH SAMPLE IN ALL MAJOR SPATIAL AXES)</p>  <p>TEMPERATUR CHANGE ACC. TO VW 801 01, SECTION 10.3, TEMPERATURE PROFILE AS SHOWN IN FIG. 6.</p> 	<p>VISUAL INSPECTION FOR CRACKS OR CHANGES</p> <p>R_D BEFORE/AFTER TEST $R_{D_{TOT}} \leq 10m\Omega$</p> <p>MONITORING FOR IMPERMISSIBLE CONTACT DISCONNETION $> 1 \mu s$ ($100mA$, $R_{THRESHOLD} = 25\Omega$)</p> <p>SAMPLING RATE: 20ns EXAMINE SURFACE FOR FREEDOM IMPERMISSIBLE HOLES DUE TO WEAR (DOCUMENT WITH PHOTOGRAPHS)</p>
<p>2.6.</p>	<p>CHEMICAL RESISTANCE TEST ACC. TO AK-TEST GUIDELINE PG 22 B, EXTENDED TEST, 4 CYCLES <u>(INCLUDING TEST WITH BATTERY ACID)</u></p>	<p>THE SAMPLES MAY DISPLAY NO FUNCTIONALLY IMPORTANT CHANGES IN THEIR DIMENSIONS AND STRUCTURE</p>
<p>2.7.</p>	<p>LONG-TERM TEST (WEAR RESISTANCE) PRE-AGING: 85°C / 48h -40°C / +85°C, 30min EACH, 100 CYCLES TRANSFER TIME $< 10s$</p>	

	TEST	REQUIREMENT																				
2.7.1.	<p>WIDEBAND NOISE TEST, 224h</p> <table border="1"> <thead> <tr> <th>frequency(Hz)</th> <th>G (m/s²)²/Hz of the speed-up</th> <th>effective value</th> <th>test time</th> </tr> </thead> <tbody> <tr> <td>10</td> <td>4,84</td> <td rowspan="3">14m/s²</td> <td rowspan="3">200h</td> </tr> <tr> <td>300</td> <td>0,163</td> </tr> <tr> <td>1000</td> <td>0,0148</td> </tr> <tr> <td>10</td> <td>9,68</td> <td rowspan="3">20m/s²</td> <td rowspan="3">24 h</td> </tr> <tr> <td>300</td> <td>0,326</td> </tr> <tr> <td>1000</td> <td>0,0296</td> </tr> </tbody> </table> <p>A PLUG CONNTECTOR IS SHAKEN IN ONLY ONE SPATIAL DIRECTION:</p> <p>VIBRATION TEST IS EXECUTED WITHOUT SUPERIMPOSED TEMPERATURE TEST.</p> <p>THE DISTRIBUTION OF THE WIRE CROSS-SECTIONS HAPPENS LINEAR OVER THE NUMBER OF CONTACTS IN THE RESPECTIVE MODULE.</p>	frequency(Hz)	G (m/s ²) ² /Hz of the speed-up	effective value	test time	10	4,84	14m/s ²	200h	300	0,163	1000	0,0148	10	9,68	20m/s ²	24 h	300	0,326	1000	0,0296	<p>VISUAL INSPECTION FOR CRACKS AND CHANGES.</p> <p>R_D BEFOR/AFTER THE TEST R_DTOT ≤ 10mΩ</p> <p>MONITORING FOR IMPERMISSIBLE CONTACT DISCONNECTIONS > 1μs (100mA, R_{THRESHOLD} = 25Ω) SAMPLING RATE: 20ns</p> <p>EXAMINE SURFACE FOR FREEDOM FROM IMPERMISSIBLE HOLES DUE TO WEAR (DOCUMENT WITH PHOTOGRAPHS)</p>
frequency(Hz)	G (m/s ²) ² /Hz of the speed-up	effective value	test time																			
10	4,84	14m/s ²	200h																			
300	0,163																					
1000	0,0148																					
10	9,68	20m/s ²	24 h																			
300	0,326																					
1000	0,0296																					

3. INSTALLATION SPACE

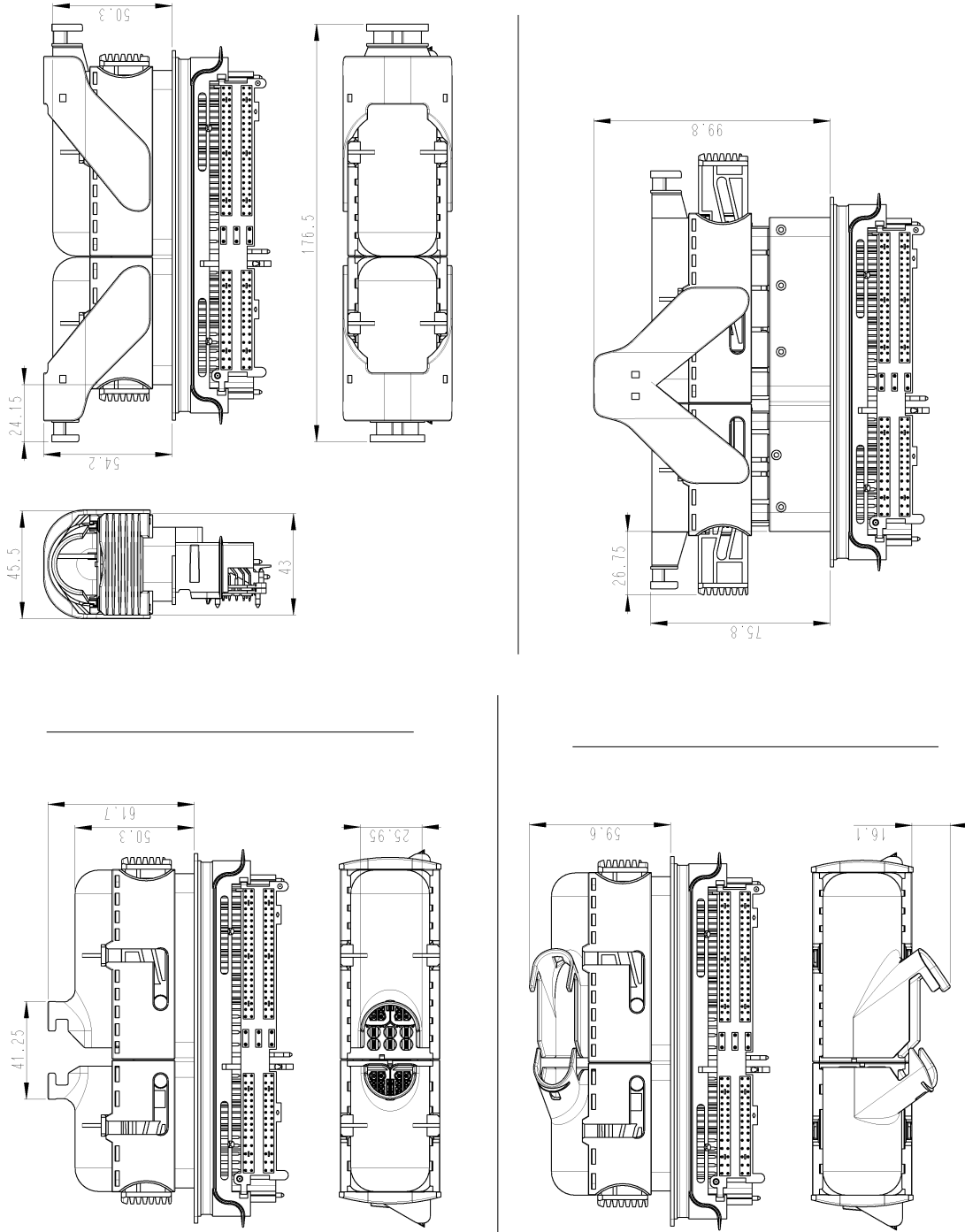

FIGURE 14