AMP PACE* Connectors

1. SCOPE

1.1. Content

This specification covers performance, tests and quality requirements for AMP PACE* (Pre-Assembled Card Edge) connectors. Connectors of this type are intended for mating with printed wiring boards having a nominal thickness of .062 inch and will provide a suitable connection between conventional wiring and printed wiring boards. Also contained in this specification, are performance criteria for the ACTION PIN* contact interface between the contact post and the printed wiring mounting board.

Specific connectors covered by this specification are .100 X .100, .100 X .200, .125 X .250 and .156 X .200 inch centerlines.

1.2. Qualification

When tests are performed on the subject product line, procedures specified in Figure 1 shall be used. All inspections shall be performed using the applicable inspection plan and product drawing.

1.3. Qualification Test Results

Successful qualification testing on the subject product line was completed in Feb82. The Qualification Test Report number for this testing is 110-14009. This documentation is on file at and available from Engineering Practices and Standards (EPS).

2. APPLICABLE DOCUMENTS

The following documents form a part of this specification to the extent specified herein. Unless otherwise specified, the latest edition of the document applies. In the event of conflict between the requirements of this specification and the product drawing, the product drawing shall take precedence. In the event of conflict between the requirements of this specification and the referenced documents, this specification shall take precedence.

2.1. Tyco Electronics Documents

- 109 Series: Test Specifications as indicated in Figure 1
- 110-14009: Qualification Test Report

2.2. Government Standard

MIL-STD-275: Printed Wiring for Electronic Equipment

3. REQUIREMENTS

3.1. Design and Construction

Product shall be of the design, construction and physical dimensions specified on the applicable product drawing.

3.2. Materials

Materials used in the construction of this product shall be as specified on the applicable product drawing.

3.3. Ratings

- Current: 3 amperes maximum with not more than 6 adjacent or opposing circuits carrying this current
- Temperature: -55 to 85°C

NOTE *The upper temperature limit includes heating effects as specified in the Current rating listed above.*

3.4. Performance and Test Description

Product is designed to meet the electrical, mechanical and environmental performance requirements specified in Figure 1.

3.5. Test Requirements and Procedures Summary

Test Description	Requirement	Procedure										
Examination of product.	Meets requirements of product drawing.	Visual, dimension and functional per applicable inspection plan.										
ELECTRICAL												
Low level contact resistance.	12 milliohms maximum total resistance. 0.5 milliohm maximum for ACTION PIN interface	AMP Spec 109-6-1. Subject specimens to 100 milliamperes maximum and 50 millivolts maximum open circuit voltage. See Figure 3.										
Contact resistance, rated current.	$V_A = .5$ milliohms. $V_B = 11.5$ milliohms. $V_T = 12$ milliohms.	AMP Spec 109-25. Test between adjacent and non-opposing contacts of unmated specimens. See Figure 3.										
Insulation resistance.	5,000 megohms minimum initial.	AMP Spec 109-28-4. Test between adjacent and non-opposing contacts of unmated specimens.										
Withstanding voltage.	<table border="0" style="margin-left: auto; margin-right: auto;"> <tr> <td>Test Voltage (AC rms)</td> <td>Altitude (feet)</td> </tr> <tr> <td>.125, .100</td> <td>Sea Level</td> </tr> <tr> <td>1,500 1,000</td> <td>50,000</td> </tr> <tr> <td>500 350</td> <td>70,000</td> </tr> <tr> <td>325 275</td> <td></td> </tr> </table> 1 minute hold with no breakdown or flashover.	Test Voltage (AC rms)	Altitude (feet)	.125, .100	Sea Level	1,500 1,000	50,000	500 350	70,000	325 275		AMP Spec 109-29-1. Test between adjacent and non-opposing contacts of unmated specimens.
Test Voltage (AC rms)	Altitude (feet)											
.125, .100	Sea Level											
1,500 1,000	50,000											
500 350	70,000											
325 275												
Permeability.	2.0μ maximum.	AMP Spec 109-88. Measure magnetic permeability.										

Figure 1 (cont)

Test Description	Requirement	Procedure
MECHANICAL		
Vibration, sinusoidal.	No discontinuities of 1 microsecond or longer duration. See Note.	AMP Spec 109-21-1. Subject mated specimens to 10-55-10 Hz traversed in 1 minute with .06 inch maximum total excursion. 2 hours in each of 3 mutually perpendicular planes.
Physical shock.	No discontinuities of 1 microsecond or longer duration. See Note.	AMP Spec 109-26. Subject mated specimens to 15 G's half-sine shock pulses of 7 milliseconds duration. 3 shocks in each direction applied along 3 mutually perpendicular planes, 18 total shocks.
Durability.	See Note.	AMP Spec 109-27. Insert and withdraw gage for 100 cycles. See Figure 4.
Contact retention.	Contacts shall not dislodge at 10 pounds for a standard ACTION PIN contact and 7.5 pounds for a reformed ACTION PIN contact.	AMP Spec 109-30. Apply specified axial load to each contact for 5 seconds with connector housing in place.
Mating force.	1 pound maximum average per contact pair.	AMP Spec 109-42. Measure force necessary to insert a .070 inch printed board simulator. Ensure the gage and specimen are properly aligned. See Figure 4.
Unmating force.	1 ounce minimum.	AMP Spec 109-42. After inserting a .070 inch gage 3 times, measure force necessary to withdraw a .054 inch gage. See Figure 5.
Housing retention.	Connector shall not move in relation to the contacts with a .5 pound load per contact applied.	AMP Spec 109-49. Apply a .5 pound per contact load evenly to the connector housing in a direction away from the board and hold for 1 minute.
Housing removeability.	See Note.	Remove housing and replace it with a new housing 5 times per applicable Instruction Sheet.
Contact repairability.	See Note.	Remove and replace 10 randomly selected contacts with new contacts per applicable Instruction Sheet.

Figure 1 (cont)

Test Description	Requirement	Procedure
Contact normal force.	100 grams minimum per contact.	Randomly measure 10 contacts per connector. If repaired, measure 20 (10 repaired, 10 non-repaired). Do subsequent measurements on the same contacts. Pre-size with 1 insertion of a .070 inch gage, then deflect the contact to the card slot barrier, then measure the force necessary to deflect the contact .027 inch from the centerline.
Contact torque.	Contacts shall not dislodge or move with a 2 inch-ounce force applied.	Apply specified force in a twisting motion in each direction and hold for 5 seconds.
ENVIRONMENTAL		
Thermal shock.	Specimens shall be capable of being mated and unmated at each temperature extreme. See Note.	AMP Spec 109-22. Subject mated specimens to 5 cycles between -55 and 85°C. Unmate and mate the specimens at the end of each temperature extreme during the fifth cycle.
Humidity-temperature cycling.	See Note.	AMP Spec 109-23-3, Method III. Subject unmated specimens to 10 cycles (10 days) between 25 and 65°C at 95% RH.
Salt fog corrosion.	See Note.	AMP Spec 109-24, Condition B. Subject unmated specimens to 5% salt concentration for 48 hours.

NOTE *Shall meet visual requirements, show no physical damage, and meet requirements of additional tests as specified in the Product Qualification and Requalification Test Sequence shown in Figure 2.*

Figure 1 (end)

3.6. Product Qualification and Requalification Test Sequence

Test or Examination	Test Group (a)		
	1	2	3
	Test Sequence (b)		
Examination of product	1	1	1
Low level contact resistance		6,15	
Contact resistance, rated current (c)	8,15,19	7,16,19	5,9
Insulation resistance	6	4,9	
Dielectric withstanding voltage (d)	7	5,10	
Permeability	2	2	2
Vibration	12		
Physical shock	14		
Durability		11	
Contact retention	18	18	
Mating force			4
Unmating force	9	12	7
Housing retention	4,16		
Housing removability (e)	3		
Contact repairability (e)	5	3	3
Contact normal force	10,13	13	8
Contact torque	17	17	
Thermal shock	11		
Humidity-temperature cycling		8	
Salt fog corrosion		14	6

NOTE

- (a) See paragraph 4.1.A.
- (b) Numbers indicate sequence in which tests are performed.
- (c) Sequence 19 of Test Groups 1 and 2 measures the ACTION PIN interface only.
- (d) Sequence 10 of Test Group 2 is measured at sea level only.
- (e) Performed on 1 randomly chosen specimen per Test Group.

Figure 2

4. QUALITY ASSURANCE PROVISIONS

4.1. Qualification Testing

A. Specimen Selection

Specimens shall be prepared in accordance with applicable Instruction Sheets and shall be selected at random from current production. All test groups shall each consist of 4 specimens; 2, 60 position and 2, 50 position. When specimens are to be mated, a mating board conforming to Figure 6 shall be used.

B. Test Sequence

Qualification inspection shall be verified by testing specimens as specified in Figure 2.

4.2. Requalification Testing

| If changes significantly affecting form, fit or function are made to the product or manufacturing
| process, product assurance shall coordinate requalification testing, consisting of all or part of the
| original testing sequence as determined by development/product, quality and reliability engineering.
|

4.3. Acceptance

| Acceptance is based on verification that the product meets the requirements of Figure 1. Failures
| attributed to equipment, test setup or operator deficiencies shall not disqualify the product. If product
| failure occurs, corrective action shall be taken and specimens resubmitted for qualification. Testing to
| confirm corrective action is required before resubmittal.
|

4.4. Quality Conformance Inspection

The applicable quality inspection plan shall specify the sampling acceptable quality level to be used. Dimensional and functional requirements shall be in accordance with the applicable product drawing and this specification.

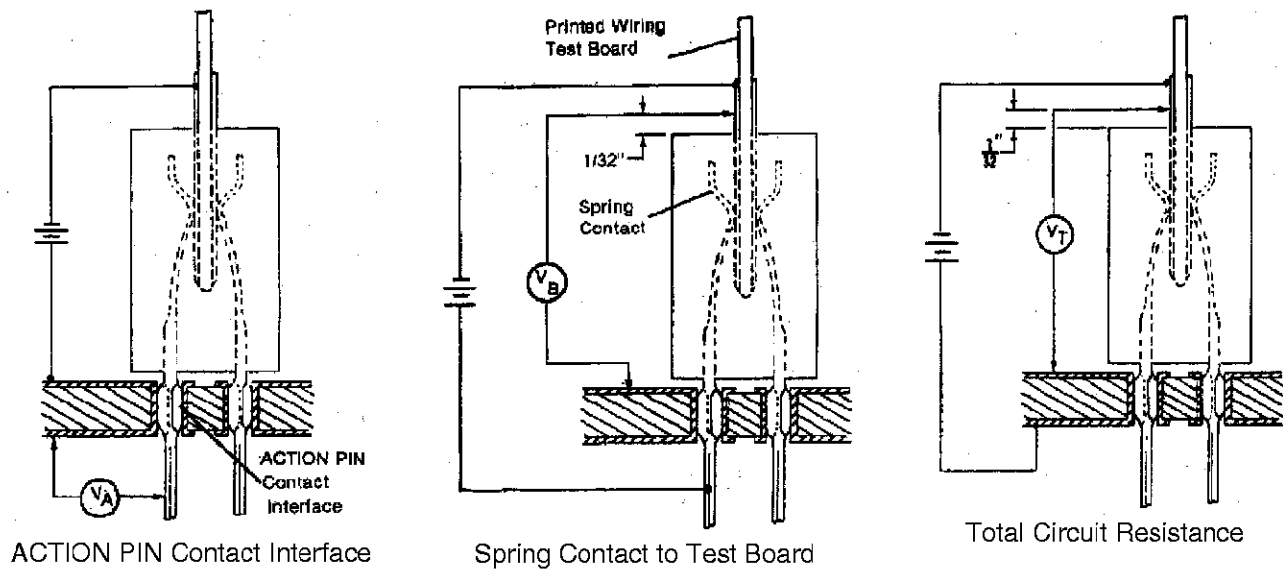

- NOTE**
- (a) V_A = Voltage drop across ACTION PIN contact interface.
 - (b) V_B = Voltage drop across test board contact.
 - (c) V_T = Overall voltage drop, including both ACTION PIN and spring contacts.

Figure 3
Contact Resistance Measurement Points

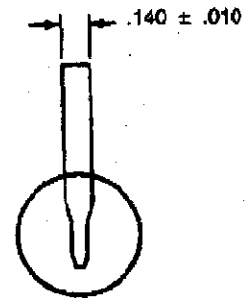
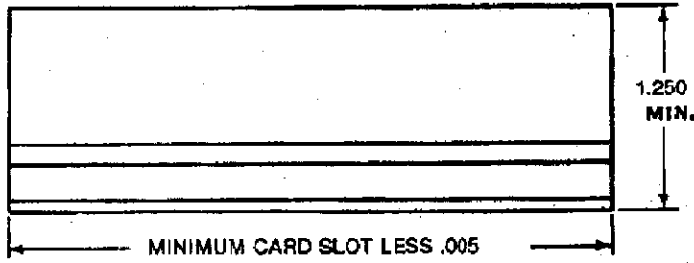

SEE DETAIL "B"

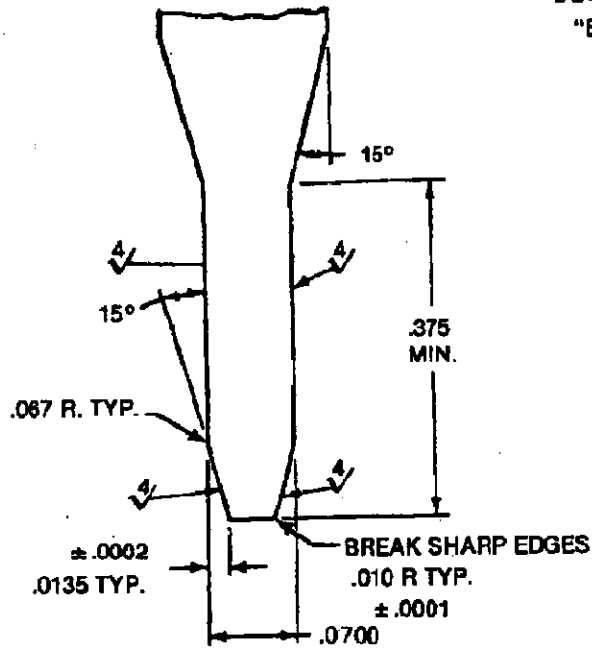

DETAIL
"B"

NOTE

- (a) Only working surfaces designated \checkmark were finished to 4 microinches maximum.
- (b) Unless otherwise specified, tolerances shall be $\pm .003$ inch.
- (c) Material shall be hardened tool steel, Rockwell C, 60-61
- (d) .002 inch TIR warpage is permitted for the full length of the gage.

Figure 4
Printed Board Simulator

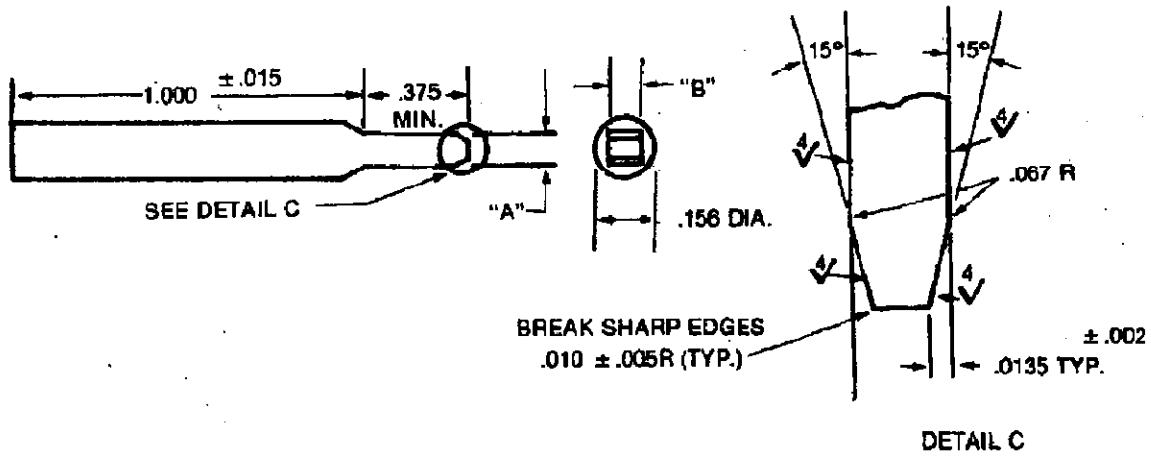

Gage Thickness	
Gage Type	"A" Dimension (± .0001)
Contact Withdrawal	.0540
Sizing	.0700

Gage Width	
Contact \varnothing Spacing	"B" Dimension (± .005)
.125	.080
.100	.075

- NOTE**
- (a) Only working surfaces designated \surd were finished to 4 microinches maximum to .375 inch from end.
 - (b) Unless otherwise specified, tolerances shall be $\pm .003$ inch.
 - (c) Material shall be hardened tool steel, Rockwell C, 58-60.

Figure 5
Printed Board Simulator

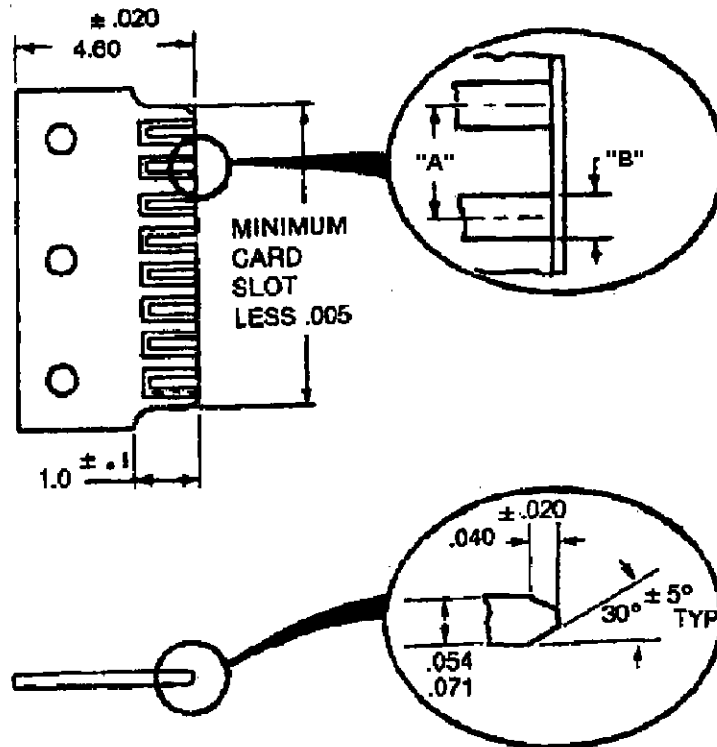

"A" Dimension	"B" Dimension
.125	.090
.100	.060

NOTE

- (a) Test boards shall conform to MIL-STD-275.
- (b) Contacts shall be as specified in MIL-STD-275, except gold plated.
- (c) Unless otherwise specified, tolerance shall be $\pm .005$ inch.

Figure 6
Mating Board Construction