



SCT Heat Shrink Tubing Specification

108-120012

Raychem SCT Tubing Adhesive-lined, semi-rigid, polyolefin heat shrink tubing, extended temperature range

SCT is a dual wall tubing designed to insulate and seal automotive wire splices and components made by ultrasonic welding, clip-and-dip, or soldering. Being semi-rigid it will also offer a degree of strain relief.

SCT has a tough outer wall made of radiation crosslinked, flame-retardant, semi-rigid polyolefin. The inner wall is a unique, specially formulated hotmelt adhesive designed to function at an extended temperature range. The adhesive forms an outstanding barrier against moisture and automotive fluids. This barrier provides exceptional protection against corrosion.

Because SCT has a high 4:1 shrink ratio, only a few sizes are needed to cover a wide range of splice and component diameters.

RoHS and REACH compliant.

Continuous operating temperature -40 to 150°C (-40 to 302°F).

THIS IS A CLASS 1 DOCUMENT WHICH IS NONCONFIDENTIAL.

The information contained within this document is the property of TE Connectivity. It is supplied in confidence and the commercial security of the contents must be maintained. It must not be used for any purpose other than that for which it is supplied nor may any information contained in it be disclosed to unauthorized persons. It must not be reproduced in whole or in part without obtaining written permission from TE Connectivity (TE).

While TE has made every reasonable effort to ensure the accuracy of the information in this catalog, TE does not guarantee that it is error-free, nor does TE make any other representation, warranty or guarantee that the information is accurate, correct, reliable or current. TE reserves the right to make any adjustments to the information contained herein at any time without notice. TE expressly disclaims all implied warranties regarding the information contained herein, including, but not limited to, any implied warranties of merchantability or fitness for a particular purpose. The dimensions in this catalog are for reference purposes only and are subject to change without notice. Specifications are subject to change without notice. Consult TE for the latest dimensions and design specifications.

*Trademark. TE Connectivity, TE connectivity (logo), and TE (logo) are trademarks. Other logos, product and/or company names may be trademarks of their respective owners.



Table of Contents

1. SCOPE 3

2. APPLICABLE DOCUMENTS 3

 2.1. AMERICAN SOCIETY FOR TESTING AND MATERIAL 3

 2.2. INTERNATIONAL ORGANIZATION FOR STANDARDIZATION..... 3

3. REQUIREMENTS 3

 3.1 DIMENSIONS 3

 3.2 MATERIALS 3

 3.3 COLOR 4

 3.4 PROPERTIES 4

4. QUALITY ASSURANCE PROVISIONS 4

 4.1 CLASSIFICATION OF TESTS 4

 4.1.1 Qualification Tests 4

 4.1.2 Acceptance Tests 4

 4.2 SAMPLING INSTRUCTIONS 4

 4.2.1 Qualification Test Samples 4

 4.2.2 Acceptance Test Samples 4

 4.2.3 Lot Formation 5

 4.3 TEST PROCEDURES 5

 4.3.1 Dimensions and Longitudinal Change 5

 4.3.2 Tensile Strength and Ultimate Elongation 5

 4.3.3 Immersion Leak Resistance..... 5

 4.3.4 Thermal Cycling 6

 4.3.5 Thermal Aging..... 6

 4.3.6 Flammability..... 6

 4.3.7 Fluid Resistance 6

 4.4 REJECTION AND RETEST 7

5. PREPARATION FOR DELIVERY 7

 5.1 FORM 7

 5.2 PACKAGING 7

 5.3 MARKING 7

APPENDIX 8

 FIGURE 1 FLAME TEST SETUP..... 8

 TABLE 1 HEAT SHOCK MANDREL DIMENSIONS..... 8

 TABLE 2 PROPERTIES 9



1. SCOPE

This Quality Assurance Specification establishes the quality standard for SCT. The objective of this document is to specify tests that will qualify the performance of SCT for protecting, insulating and sealing components in an under-the-hood automotive environment. This specification covers the requirements for a dual wall, electrically insulating, extruded tubing, whose diameter will reduce to a predetermined size upon application of heat in excess of 135°C (275°F).

2. APPLICABLE DOCUMENTS

This specification takes precedence over documents referenced herein. Unless otherwise specified, the latest issue of the referenced documents applies. The following documents form a part of this specification to the extent specified herein.

2.1. AMERICAN SOCIETY FOR TESTING AND MATERIAL (ASTM)

ASTM D149	Standard Test Method for Dielectric Breakdown Voltage and Dielectric Strength of Solid Electrical Insulating Materials at Commercial Power Frequencies
ASTM D257	Standard Test Methods for DC Resistance or Conductance of Insulating Materials
ASTM D471	Standard Test Method for Rubber Property—Effect of Liquids
ASTM D975	Standard Specification for Diesel Fuel Oils
ASTM D2671	Standard Methods of Testing Heat-Shrinkable Tubing for Electrical Use

(Copies of ASTM publications may be obtained from the American Society for Testing and Materials, 1916 Race Street, Philadelphia, Pennsylvania 19103 or via the ASTM website at <http://www.astm.org>).

2.2. International Organization for Standardization (ISO)

ISO 6722-1	Road vehicles – 60 V and 600 V single core cables -- Part 1: Dimensions, test methods and requirements for copper conductor cables.
------------	---

(Copies of ISO publications may be obtained from the International Organization for Standardization, 1, rue de Varembé, CH-1211 Geneva 20, Switzerland or via the ISO website at <http://www.iso.ch/iso/en/ISOOnline.frontpage>)

3. REQUIREMENTS

3.1. DIMENSIONS

The dimensions shall be in accordance with SCT SCD.

3.2. MATERIALS

The tubing components shall be essentially free from pinholes, bubbles, cracks, defects and inclusions and shall be constructed as a dual walled heat shrinkable tubing having

SCT Specification



a hot melt adhesive inner wall with an outer wall of an irradiated, modified polyolefin material.

3.3. COLOR

The jacket color shall be Black. Inner adhesive wall shall be light amber.

3.4. MARKING

Marking is SCT-0, SCT-1, SCT-2, SCT-3, SCT-4, SCT-5 and SCT-7. Size SCT-3A is not printed.

3.5. PROPERTIES

The tubing shall meet the requirements of Table 2.

4. QUALITY ASSURANCE PROVISIONS

4.1. CLASSIFICATION OF TESTS

4.1.1. Qualification Tests

Qualification tests are those performed on tubing submitted for qualification as a satisfactory product and shall consist of all tests listed in this specification.

4.1.2. Acceptance Tests

Acceptance tests are those performed on tubing submitted for acceptance under contract. Acceptance tests shall consist of:

Dimensions
Tensile Strength
Ultimate Elongation
Heat Shock

4.2. SAMPLING INSTRUCTIONS

4.2.1. Qualification Test Samples

Qualification test samples shall consist of 45 m (150 feet) of tubing of SCT-2 (qualifies SCT-1, SCT-2 and SCT-3, SCT-3A) and SCT-4 (qualifies SCT-4, SCT-5 and SCT-7).

4.2.2. Acceptance Test Samples

Acceptance test samples shall consist of not less than 5 m (16 feet) of tubing selected at random from each lot. A lot shall consist of all tubing of the same size from the same production run and offered for inspection at the same time.



4.2.3. Lot Formation

A lot shall consist of all tubing of the same size, from the same production run, and offered for inspection at the same time.

4.3. TEST PROCEDURES

Unless otherwise specified, perform tests on specimens which have been recovered by heating for 3 minutes in a $200 \pm 5^{\circ}\text{C}$ ($392 \pm 9^{\circ}\text{F}$) oven. Condition the test specimens (and measurement gauges when applicable) for 3 hours at $23 \pm 3^{\circ}\text{C}$ ($73 \pm 5^{\circ}\text{F}$). For referee purposes, condition the test specimens at 50 ± 5 percent relative humidity for 3 hours prior to testing. Use mechanical convection type ovens in which air passes the specimens at a velocity of 30 to 60 m (*100 to 200 feet*) per minute.

4.3.1. Dimensions and Longitudinal Change

Measure three 150 mm (*6 inch*) specimens of tubing, as supplied, for length ± 1 mm ($\pm 1/32$ inch) and inside diameter in accordance with ASTM D 2671. Condition the specimens with adhesive for 3 minutes in a $200 \pm 5^{\circ}\text{C}$ ($392 \pm 9^{\circ}\text{F}$) oven, cool to $23 \pm 3^{\circ}\text{C}$ ($73 \pm 5^{\circ}\text{F}$), then re-measure. Prior to and after conditioning, the dimensions of the tubing shall be in accordance with SCT SCD and the longitudinal change shall be in accordance with Table 2. Calculate the longitudinal change as follows:

$$\text{LC} = \frac{(L_1 - L_0)}{L_0} \times 100$$

Where: LC = Longitudinal Change [percent]
L₀ = Length Before Conditioning [inches (mm)]
L₁ = Length After Conditioning [inches (mm)]

4.3.2. Tensile Strength and Ultimate Elongation

Perform the tests in accordance with ASTM D2671 using a jaw separation speed of 50 ± 5 mm (*2.0 \pm 0.2 inches*) per minute. Calculate the tensile strength based on the wall thickness of the jacket only.

4.3.3. Immersion Leak Resistance

A) Size SCT-2

Prepare 3 test assemblies insulated with SCT-2 as follows:

Construct a 2-wire to 2-wire inline splice in any suitable manner (crimped, soldered, twisted or welded). Splice an AWG 18 and an AWG 14 to an AWG 20 and AWG 14. Each wire shall be approximately 12 inches long. The wire insulation shall be cross-linked polyolefin and the conductor shall be bare copper. Shrink a 2-inch length of SCT-2 over the splice area with an appropriate heat gun. Apply heat until the SCT-2 is completely recovered on the splice and the adhesive liner flows at both ends. Allow the test assemblies to cool to room temperature and immerse them, except for the ends, in a 5% salt

SCT Specification



solution for 24 hours at room temperature. Apply 50 volts DC to the immersed specimens and measure the current leakage.

B) Size SCT-4

Prepare 3 test assemblies with SCT-4 as follows:

Construct a 3-wire to 3-wire to 3-wire inline splice in any suitable manner (crimped, soldered, twisted or welded). Splice three AWG 12 wires to three AWG 12 wires. Each wire shall be approximately 12 inches long. The wire insulation shall be cross-linked polyolefin and the conductor shall be bare copper. Shrink a 3-inch length of SCT-4 over the splice area with an appropriate heat gun. Apply heat until the SCT-4 is completely recovered on the splice and the adhesive liner flows at both ends. While the assembly is still hot from the recovery process, press the ends of the SCT-4 together where the wires emerge. Using parallel jaw pliers, align the wires and assure that they are completely coated with adhesive. Allow the test assemblies to cool to room temperature and immerse them, except for the ends in a 5% salt solution for 24 hours at room temperature. Apply 50 volts DC to the immersed specimens and measure the current leakage.

4.3.4. Thermal Cycling

Prepare 3 splice assemblies in accordance with Sec. 4.3.3. and subject them to 25 thermal cycles. One cycle consists of 30 minutes at -40°C and 30 minutes at 135°C with a maximum of 5 minutes between temperatures. Specimens shall be allowed to cool to room temperature for one hour minimum and shall be measured for current leakage in accordance with Sec. 4.3.3.

4.3.5. Thermal Aging

Prepare 3 splice assemblies in accordance with Sec. 4.3.3. and heat for 1000 hrs. at 150°C. Specimens shall be allowed to cool to room temperature for one hour minimum and shall be measured for current leakage in accordance with Sec. 4.3.3.

4.3.6. Flammability

The test method shall be essentially in accordance with ISO6722.

Recover five 500 mm (20 inch) lengths of tubing with adhesive over mandrels with a diameter 75 ± 5 percent of the specified minimum expanded (as supplied) inside diameter of the tubing.

Using a Bunsen burner with a 100 mm (4 inch) tube, adjust the burner to achieve a flame with an inner blue cone of approximately 50 mm (2 inches).

Suspend each specimen in a draft free environment in the configuration shown in Figure 1. The time of exposure of the test flame to each specimen is one 30 second application.

Record the time for each specimen to self-extinguish after removal of the flame. The result is the average burning time for all five specimens.

4.3.7. Fluid Resistance

Prepare 9 splice assemblies in accordance with Sec. 4.3.3. and immerse 3 assemblies in each of the fluids specified for 24 hours at the specified temperature. Measure current leakage in accordance with Sec. 4.3.3.



4.4. REJECTION AND RETEST

Failure of any sample of tubing to conform to any one of the requirements of this specification shall be cause for rejection of the lot represented. Tubing which has been rejected may be replaced or reworked to correct the defects and resubmitted for acceptance. Before resubmitting, full particulars concerning previous rejection and action taken to correct the defects shall be furnished to the inspector.

5. PREPARATION FOR DELIVERY

5.1. FORM

5.1.1. The tubing shall be supplied in cut pieces, unless otherwise specified.

5.2. PACKAGING

5.2.1. Packaging shall be in accordance with good commercial practice.

5.3. MARKING

5.3.1. Each container of tubing shall be permanently and legibly marked with the size, quantity, manufacturer's identification, part number and lot number.



APPENDIX

**Figure 1
Flame Test Setup**

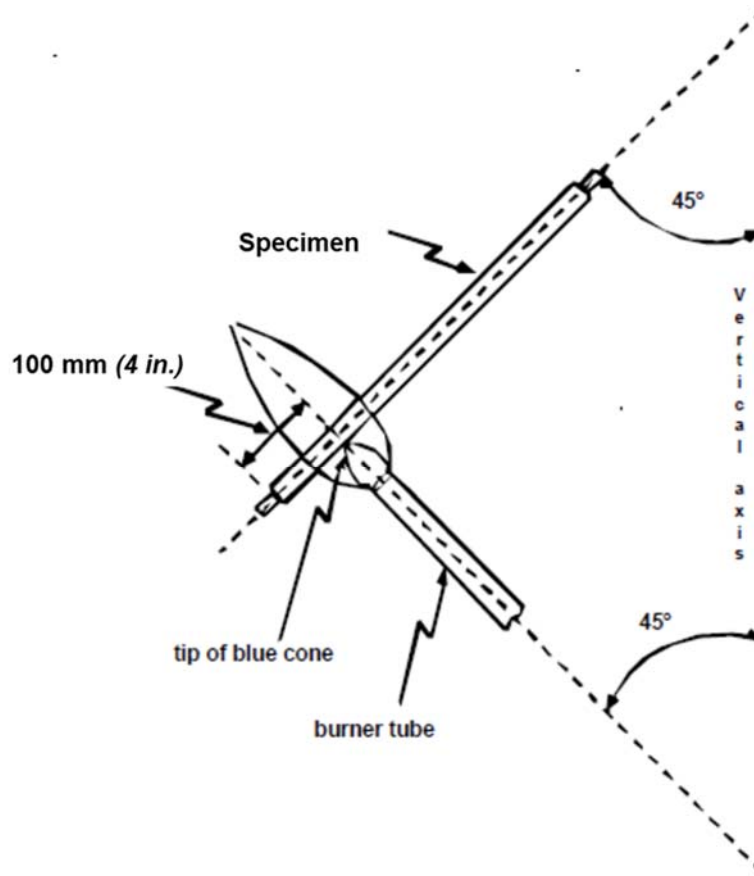

**Table 1
Heat Shock Mandrel Dimensions**

Expanded Tubing ID		Mandrel Diameter	
mm	inches	mm	inches
1.19 to 4.76	0.046 to 0.188	12.7 ± 0.10	0.500 ± 0.004
4.77 to 25.4	0.250 to 1.00	19.1 ± 0.13	0.750 ± 0.005



Table 2
Properties

Property	Unit	Requirements	Test Method
Dimensions	mm (<i>inches</i>)	SCT SCD	ASTM D 2671
Tensile Strength	MPa (<i>psi</i>)	10.3 (<i>1500</i>) minimum	ASTM D 2671
Ultimate Elongation	Percent	300 minimum	ASTM D 2671 Speed 2 in./min. Sec 4.3.2.
Secant Modulus (Expanded Tubing)	MPa (<i>psi</i>)	241 (3.5×10^4) minimum	ASTM D 2671 Speed 2 in./min.
Longitudinal Change	Percent	+0 to -10	ASTM D 2671 Sec 4.3.1.
Concentricity (Expanded Form)	Percent	60 minimum	ASTM D 2671
Dielectric Strength* (Jacket Only)	Volts/mm (<i>Volts/mil</i>)	19,700 (<i>500</i>) minimum	ASTM D 149
Volume Resistivity	Ohm-cm	10^{13} minimum	ASTM D 257
Immersion Leak Resistance	Micro-amps	0.25 maximum	Sec 4.3.3.
Thermal Cycling 25 cycles -40°C to 135°C, followed by: Immersion Leak Resistance,	Micro-amps	0.25 maximum	Sec 4.3.4.
Heat Shock 4 hrs. @ 250°C	--	No dripping, flowing or cracking of jacket	ASTM D 2671 Table 1
Thermal Aging 1000 hrs. @ 150°C, followed by: Immersion Leak Resistance,	Micro-amps	0.25 maximum	Sec 4.3.5.
Flammability	---	Self-extinguishing within 30 sec	Sec 4.3.6. ISO 6722-1
Fluid Resistance 24 hrs. @ 25 ± 3°C ASTM D471 Reference Fuel C ASTM D975 Diesel Fuel 24 hrs. @ 100 ± 3°C ASTM D471 IRM 903 (formally #3 Oil) Followed by: Immersion Leak Resistance, Sec 4.3.3.	Micro-amps	0.25 maximum	Sec 4.3.7.