

PART NUMBER	REV	FIRST USED
680294 -1	A	854400-1
680294 -2	A	565435-5

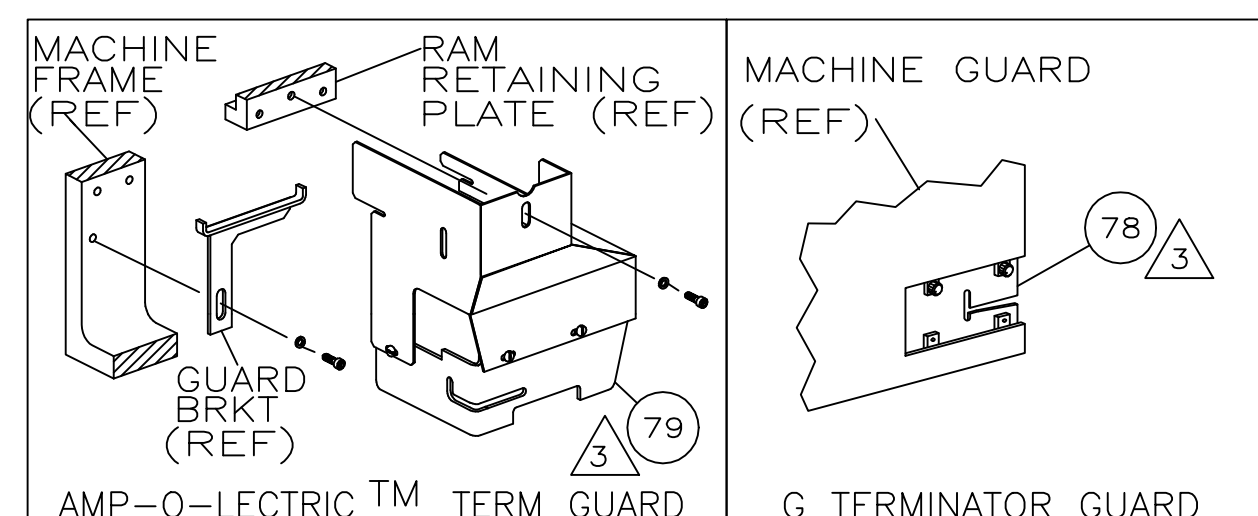

TERMINAL NAME: 2.5mm FLAG CONTACT, SOCKET		CRIMPING DATA	
PAD LTR	CRIMP HEIGHT	WIRE SIZE	
A	.044 ±.001 [1.11 ±0.03mm]	0.35mm ² or 22	
B	.042 ±.001 [1.07 ±0.03mm]	0.25mm ² or (2)26	
C	.041 ±.001 [1.05 ±0.03mm]	0.20mm ² or (2)28	
D	NOT USED		
CRIMP	SIZE	TYPE	RANGE
WIRE	.062 [1.57mm]	F	0.20mm ² -0.35mm ²
INSUL	.090 [2.29mm]	F	Ø1mm-1.6mm

WIRE STRIP LENGTH	TERM APPL SPEC	FEED	APPL INSTRUCTION	SET UP GAGE	LAYOUT
-	114-18031-1	.788	408-8039	458638-1	L1527

REV	LEADMAKER & BENCH MODEL	AIRFEED
-1	LEADMAKER & BENCH MODEL G	AIRFEED
-2	BENCH MODEL K	AIRFEED

USED ON

THIS DRAWING IS A CONTROLLED DOCUMENT.

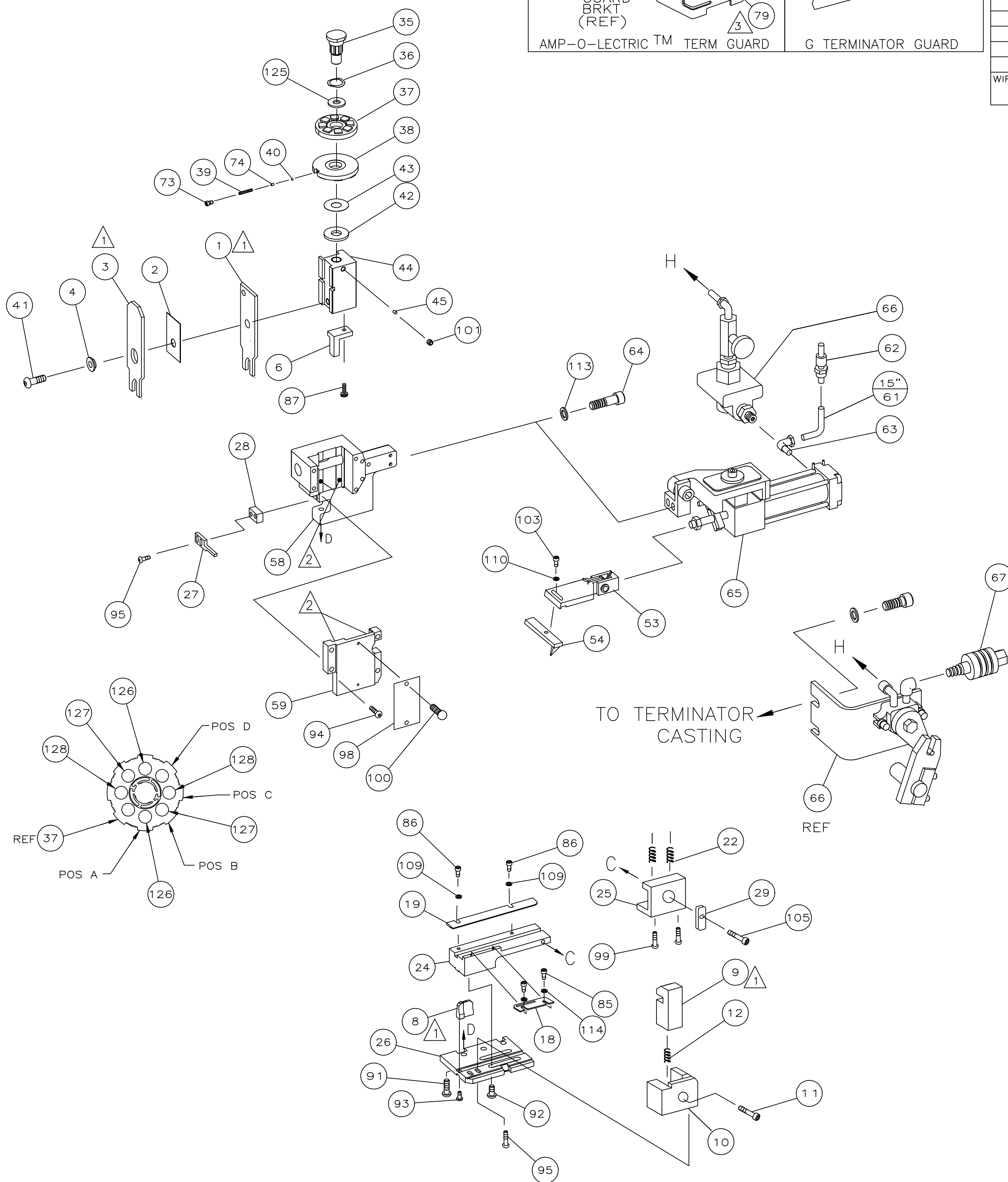

QTY	REQD	PER ASSY	PARTS LIST	ITEM NO		
2	2	-	C	3-354779-3	PIN, WIRE DISC (.3155)C	129
2	2	-	C	3-354779-0	PIN, WIRE DISC (.3140)B	128
2	2	-	C	2-354779-5	PIN, WIRE DISC (.3115)A	126
1	1	-	A	986950-1	WASHER, FLAT PRECISION	125
						124
						123
						122
						121
						120
						119
						118
						117
						116
						115
2	2	-	A	21024-2	WASHER, LOCK(NO.4)ST GU PL	114
2	2	-	A	21024-5	WASHER, LOCK(NO.10)SHEAR PL	113
						112
						111
1	1	-	A	21024-4	WASHER, LOCK(NO.8)FEED	110
2	2	-	A	21024-3	WASHER, LOCK(NO.6)ST GU PL	109
						108
						107
						106
1	1	-	A	22353-8	SCR, SHLD(Ø187x.25)DRAG LEVER	105
						104
1	1	-	A	2-22603-0	SCR, SHC(8-32x.38)FEED HOLDER	103
2	2	-	A	2-21006-6	SCR, SKT SET(4-40x.62)DRAG	102
1	1	-	A	21009-2	SCR, SKT SET(1/4-20x.25)RAM	101
2	2	-	A	21017-2	SCR, DRIVE(#2x.19)ID PLATE	100
2	2	-	A	3-21002-0	SCR, BHC(10-32x.88)DRAG	99
1	1	-	B	461264-1	PLATE, IDENTIFICATION	98
						97
						96
2	2	-	A	2-21002-2	SCR, BHC(8-32x.50)STRIPPER	95
4	4	-	A	2-21002-9	SCR, BHC(10-32x.75)CAP	94
1	1	-	A	22733-8	SCR, BHC(8-32x.38 LW)ANVIL	93
4	4	-	A	3-21002-3	SCR, BHC(1/4-20x.50)ST GD PL	92
3	3	-	A	2-22733-8	SCR, BHC(1/4-20x.62)HSG	91
						90
						89
						88
1	1	-	A	2-21000-7	SCR, SHC(8-32x.50)SHEAR DEP	87
2	2	-	A	2-21000-0	SCR, SHC(6-32x.50)STRIP GUIDE	86
2	2	-	A	1-21000-3	SCR, SHC(4-40x.25)F ST GU	85
						84
						83
						82
						81
2	2	-	A	3-21000-8	SCR, SKT CAP(10-32x.88)SH PL	80
1	-	-	A	455750-7	GUARD ASSY	79
-	-	REF	A	679532-1	INSERT, GUARD	78
						77
						76
						75
1	1	-	A	690603-1	SPRING, ASSIST	74
1	1	-	A	23030-1	SCR, SKT CAP(6-32x.25)CP DSC	73
						72
						71
-2	-1	U/M	DWG SIZE	PART NO	DESCRIPTION	ITEM NO

- ① RECOMMENDED SPARE PARTS.
- ② GREASE LIGHTLY.
- ③ GUARD MUST BE IN PLACE WHEN OPERATING APPLICATOR IN A BENCH MACHINE.
- ④ SEE DRAWING FOR COMPONENTS
- ⑤ ITEM 78 REQUIRED FOR BENCH G TERMINATOR ONLY.

QTY	REQD	PER ASSY	PARTS LIST	ITEM NO		
1	-	-	C	692655-5	AIR FEED VALVE ASSY	70
						69
REF	-	-	A	24042-2	VALVE, SHUT OFF	67
REF	-	-	C	692655-6	AIR FEED VALVE ASSY	66
1	1	-	B	460277-1	AIR FEED ASSY	65
2	2	-	A	3-21000-9	SCR, SHC 10-32x1.00 AIR ASSY	64
-	1	-	A	983427-6	ELBOW, TUBING 1/8NPT - 1/4 T	63
-	1	-	A	23238-1	QUICK DISCONNECT	62
12.00	12.00	IN	A	27319-4	TUBING, POLY-FLO Ø25	61
						60
1	1	-	C	467284-1	CAP, RAM	59
1	1	-	D	683742-1	HOUSING	58
						57
						56
						55
1	1	-	B	679904-2	PAWL, FEED	54
1	1	-	B	461062-1	HOLDER, FEED FINGER	53
						52
						51
						50
						49
						48
						47
						46
1	1	-	A	690191-1	PLUG, NYLON	45
1	1	-	C	683741-2	RAM	44
1	1	-	A	690125-1	WASHER, LAMINATED	43
1	1	-	A	1-690124-4	WASHER, RAM	42
1	1	-	A	7-21002-9	BOLT, CRIMPER(5/16-24x1.00)	41
1	1	-	A	23241-6	BALL, STEEL	40
1	1	-	A	690170-1	SPRING, COMPRESSION	39
1	1	-	C	690142-1	DISC, INSULATION	38
1	1	-	D	354777-1	WIRE DISC, PLASTIC	37
1	1	-	A	22480-5	WASHER, SPRING	36
1	1	-	B	690212-1	POST, RAM	35
						34
						33
						32
						31
						30
1	1	-	B	240793-1	LEVER, DRAG RELEASE	29
1	1	-	B	3-690451-2	SPACER, STRIPPER	28
1	1	-	A	240639-1	STRIPPER	27
1	1	-	D	679850-1	PLATE, BASE	26
1	1	-	B	240792-1	DRAG, TERMINAL	25
1	1	-	B	679868-1	PLATE, STRIP GUIDE	24
						23
2	2	-	A	1-22284-0	SPRING, DRAG	22
						21
						20
1	1	-	B	679768-1	GUIDE, STRIP (REAR)	19
1	1	-	C	690438-2	GUIDE, STRIP (FRONT)	18
						17
						16
						15
						14
						13
1	1	-	A	5-22280-0	SPRING, SHEAR	12
1	1	-	A	1-609461-3	STOP, SHEAR	11
1	1	-	B	679829-1	HOLDER, SHEAR	10
1	1	-	C	679835-1	SHEAR, FLOATING	9
1	1	-	D	679887-3	ANVIL	8
						7
1	1	-	B	467499-3	HOLD DOWN, TERMINAL	6
						5
1	1	-	B	1-238009-4	SPACER, BLOCK CRIMPER	4
1	1	-	C	6-456134-0	CRIMPER, INSULATION	3
1	1	-	B	1-455888-2	SPACER, CRIMPER	2
1	1	-	C	3-456403-7	CRIMPER, WIRE	1

MACHINE REF	M. O'BRINE	3-29-96	MATERIAL	HEAT TREAT
MINI APPL				
DIMENSIONS: INCHES	TOLERANCES UNLESS OTHERWISE SPECIFIED:			
0 PLC ±.005	1 PLC ±.002			
2 PLC ±.003	3 PLC ±.004			
4 PLC ±.005				
APVD	APVD	3-29-96	STE TE Connectivity	
END FEED HDM APPLICATOR				
SCALE	SIZE	DRAWING NO	SHEET	REV
-	A1	680294	1 OF 1	A1

THIS INFORMATION IS CONFIDENTIAL AND PROPRIETARY TO TFCO AND IS NOT TO BE DISCLOSED TO ANY OTHER PERSON OR ENTITY WITHOUT THE WRITTEN AUTHORIZATION OF TFCO.