

PART NUMBER	REV	FIRST USED
680203-2	B	565435-5
680203-3	A	354500-1

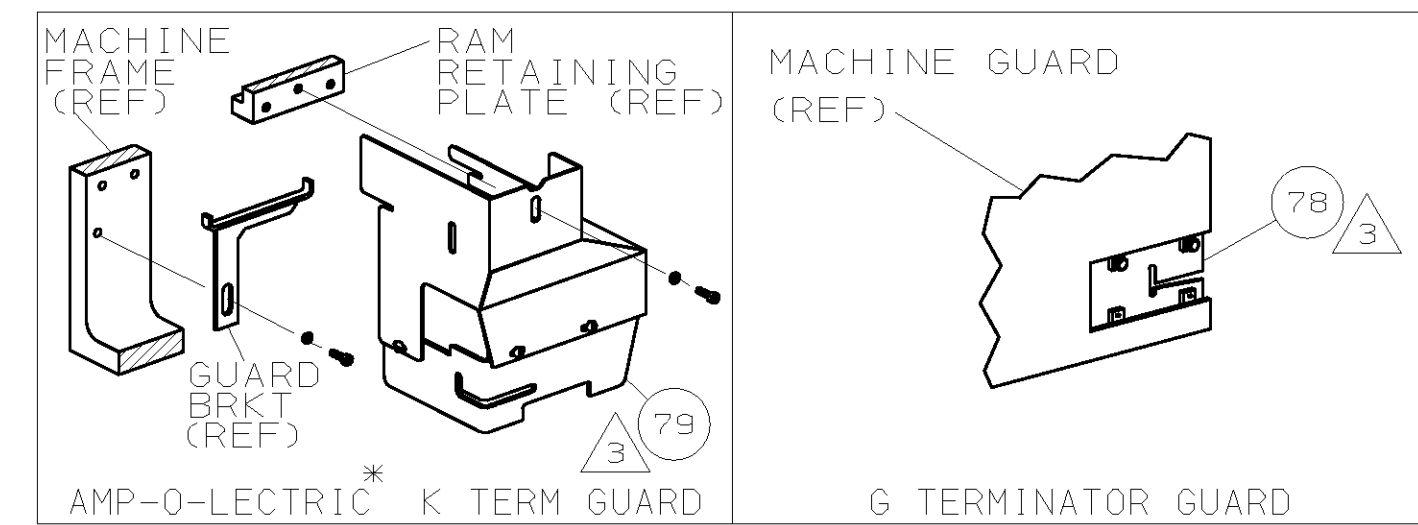

TERMINAL NAME:	
AMPLIVAR™ SPLICE WITH INSULATION SUPPORT	141175
TERM APPL SPEC	114-2008

CRIMPING DATA			
PAD LTR	CRIMP HEIGHT	WIRE SIZE	
A	.034 ±.002(0.87±0.05mm)	5	
B	NOT USED	NOT USED	
C	NOT USED	NOT USED	
D	NOT USED	NOT USED	
CRIMP	SIZE	TYPE	RANGE
WIRE	.080	F	5
INSUL	.130	F	.100-.150
FEED	.395	APPL INST	SET UP GAGE LAYOUT
		408-8039	- L1679
WIRE STRIP LENGTH		-	

-2	BENCH MODEL K	AIRFEED
-3	BENCH MODEL G	AIRFEED

4	1	-	C	692655-5	AIR FEED VALVE ASSY	70
1	1	-	A	461690-1	SPACER, AIR FEED	68
-	REF	-	A	24042-2	VALVE, SHUT OFF	67
4	REF	-	C	692655-6	AIR FEED VALVE ASSY	66
1	1	-	B	460277-1	AIR FEED ASSY	65
2	2	-	A	4-21000-3	SCR,SHC 10-32X2.00 AIR ASSY	64
1	-	-	A	22294-6	ELBOW, TUBING 1/8NPT - 1/4 T	63
1	-	-	A	23238-1	QUICK DISCONNECT	62
12.00	12.00	IN	A	27319-4	TUBING, POLY-FLO Ø.25	61

						129
						128
						127
2	2	-	C	5-354779-4	PIN, WIRE DISC (.3260)A	126
1	1	-	A	986950-1	WASHER, FLAT PRECISION	125
						124
						123
						122
						121
						120
2	2	-	A	1-21002-6	SCR,BHC (6-32X .25)PLATE,STR GUI	119
						118
						117
1	1	-	A	21018-6	NUT, HEX (8-32)LUBE	116
1	1	-	A	21055-6	WASHER, FLAT #8 LUBE	115
2	2	-	A	22260-7	WASHER, FLAT #10	114
4	4	-	A	21024-3	WASHER, LOCK (NO.6) SHEAR PL	113
						112
2	2	-	A	4-21000-2	SCR,SHC (10-32X 2.00)AIR FEED BRKT	111
7	7	-	A	21024-4	WASHER, LOCK (NO.8) SHEAR BL	110
						109
2	2	-	A	21018-4	NUT, HEX (4-40) DRAG	108
						107
						106
2	2	-	A	21022-2	NUT, HEX SL (8-32) DRAG STUD	105
						104
						103
2	2	-	A	4-21078-8	SKT SKT SET (4-40x.75)DRAG	102
1	1	-	A	21009-2	SCR,SKT SET (1/4-20x.25)RAM	101
2	2	-	A	21017-2	SCR,DRIVE (#2x.19) ID PLATE	100
						99
1	1	-	B	464249-1	PLATE, IDENTIFICATION	98
						97
						96
2	2	-	A	3-21000-2	SCR,SHC (8-32X1.25) STRIPPER	95
4	4	-	A	2-21002-9	SCR,BHC (10-32x.75) CAP	94
2	2	-	A	2-21002-8	SCR,BHC (10-32x.58)	93
4	4	-	A	3-21002-5	SCR,BHC (1/4-20x.75) ST GD PL	92
3	3	-	A	2-22733-8	SCR,BHC (1/4-20x.62) H5G	91
						90
						89
						88
1	1	-	A	2-21000-9	SCR,SHC (8-32x.75) LUBE	87
1	1	-	A	2-21000-6	SCR,SHC (8-32x.38) STRIP GUIDE	86
4	4	-	A	2-21002-2	SCR,SHC (8-32x.50) R STRIP GUIDE	85
						84
						83
						82
						81
2	2	-	A	1-21000-9	SCR,SKT CAP (6-32x.38) SH PL	80
-	1	-	A	460980-2	GUARD ASSY	79
REF	-	-	A	679532-1	INSERT, GUARD	78
1	1	-	C	1-465184-7	LUBRICATOR ASSY	77
						76
						75
1	1	-	A	690603-1	SPRING, ASSIST	74
1	1	-	A	23030-1	SCR,SKT CAP (6-32x.25) CP DSC	73
-	1	-	A	22317-3	ELBOW, COPPER TUBE	72
						71

						60	
						59	
						58	
						57	
						55	
						54	
4	1	1	-	B	460680-7	FEED FINGER ASSY	53
						52	
						51	
						50	
1	1	-	B	7-21002-9	BOLT, CRIMPER	49	
1	-	-	A	318848-1	AIR BLAST ASSEMBLY	48	
-	1	-	A	455350-1	AIR BLAST ASSEMBLY	47	
-	1	-	A	689446-2	TUBE, AIR BLAST	46	
1	1	-	A	690191-1	PLUG, NYLON	45	
1	1	-	C	459586-1	RAM	44	
1	1	-	A	690125-1	WASHER, LAMINATED	43	
1	1	-	A	690124-4	WASHER, RAM	42	
						41	
1	1	-	A	23241-6	BALL, STEEL	40	
1	1	-	A	690170-1	SPRING, COMPRESSION	39	
1	1	-	C	690142-1	DISC, INSULATION	38	
1	1	-	D	354777-1	WIRE DISC, PLASTIC	37	
1	1	-	A	22480-5	WASHER, SPRING	36	
1	1	-	B	690212-1	POST, RAM	35	
						34	
						33	
						32	
						31	
						30	
						29	
1	1	-	B	1-690451-6	SPACER, STRIPPER	28	
1	1	-	A	460276-1	STRIPPER	27	
1	1	-	D	459584-1	PLATE, BASE	26	
2	2	-	A	22354-8	DRAG, STUD	25	
1	1	-	B	462931-2	PLATE, STRIP GUIDE	24	
1	1	-	C	462932-5	PLATE, STRIP COVER	23	
2	2	-	A	4-22281-1	SPRING, DRAG	22	
						21	
1	1	-	A	462925-1	DRAG, STOCK	20	
1	1	-	B	462929-3	GUIDE, STRIP (REAR)	19	
1	1	-	C	462930-3	GUIDE, STRIP (FRONT)	18	
						17	
						16	
						15	
						14	
						13	
						12	
1	1	-	B	459684-7	PLATE, GUIDE RETAINER	11	
1	1	-	B	459580-1	PLATE, ANVIL RETAINER	10	
1	1	-	B	459583-8	BODY, ANVIL	9	
1	1	-	D	318573-1	ANVIL	8	
1	1	-	B	459581-1	BLADE, SLUG	7	
						6	
1	1	-	C	459587-1	CRIMPER GUIDE	5	
1	1	-	B	238009-1	SPACER, BLOCK CRIMPER	4	
1	1	-	C	1-456134-9	CRIMPER, INSULATION	3	
1	1	-	B	455888-5	SPACER, CRIMPER	2	
1	1	-	C	1-459585-3	CRIMPER, WIRE	1	

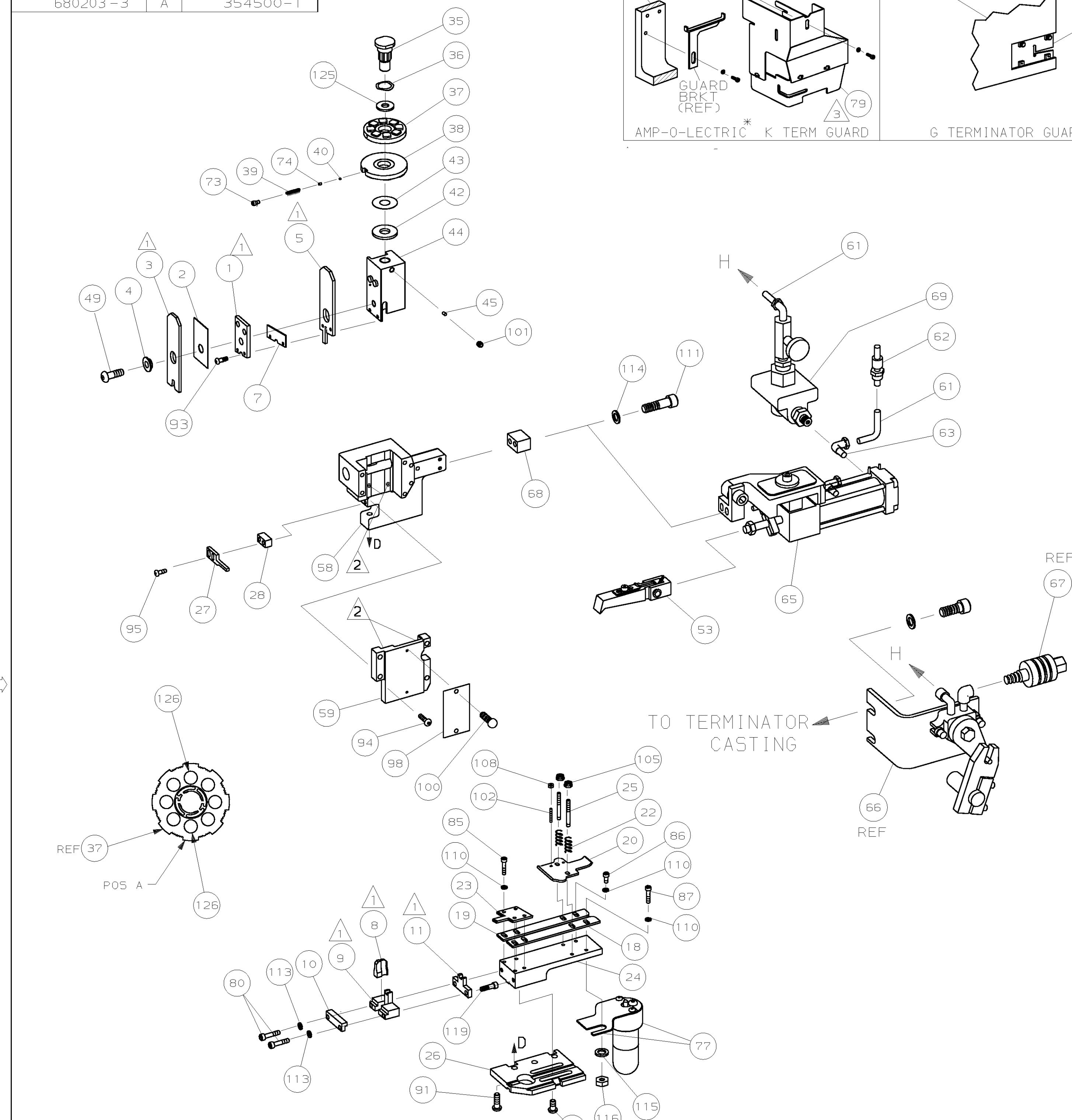

* Trademark of AMP Incorporated

TO AIR BLAST ASSY (ITEM 47)

FOR -2

1 RECOMMENDED SPARE PARTS.
 2 GREASE LIGHTLY.
 3 GUARD MUST BE IN PLACE WHEN OPERATING APPLICATOR IN A BENCH MACHINE.
 4 SEE DRAWING FOR COMPONENTS
 5 1 Ø 0.375 mm OR
 1 Ø 0.355 mm OR
 2 Ø 0.280 mm
 MAG WIRE

QTY	REV	U/M	DWG SIZE	PART NO	DESCRIPTION	ITEM NO
-3	-2					

QTY	REV	U/M	DWG SIZE	PART NO	DESCRIPTION	ITEM NO
-3	-2					

LOC	DIST
A	66

P	F	L	T	R	REVISION RECORD	APP	DATE

DIMENSIONS IN INCHES. DO NOT SCALE PRINT. TOLERANCES UNLESS OTHERWISE SPECIFIED:
 2 PLC DEC ±.25
 3 PLC DEC ±.
 4 PLC DEC ±.
 ANGLES ±.
 SURF TEXTURE: ✓
 REMOVE BURRS, BREAK SHARP EDGES R.015 MAX

MATL - HT TR - FIN -

DR P.MATHIAS 10-13-95 APP A.BEDDICK 10-16-95
 CHK 10-16-95 REL 3/1/96
 C.ERISMAN B. MORGAN

AMP Incorporated Harrisburg, PA 17105-3608

NAME END FEED HDM APPLICATOR MACHINE REF
 SCALE - DWG NO 680203 SHEET 1 OF 1 REV B

THIS DRAWING IS A CONTROLLED DOCUMENT FOR AMP INCORPORATED. IT IS SUBJECT TO CHANGE AND THE CONTROLLING ENGINEERING ORGANIZATION SHOULD BE CONTACTED FOR THE LATEST REVISION.

THIS INFORMATION IS CONFIDENTIAL AND IS DISCLOSED TO YOU ON CONDITION THAT NO FURTHER DISCLOSURE IS MADE BY YOU TO OTHER THAN AMP PERSONNEL WITHOUT WRITTEN AUTHORIZATION FROM AMP INCORPORATED, HARRISBURG, PA.

680203