

PART NUMBER		REV	FIRST USED
680008-1		B	854400-1
680008-2		E	565435-5

OBSOLETE

REVISIONS			
REV	DESCRIPTION	DATE	BY
E	ECR-16-009647	08JULY216	JH LZ

1	LEADMAKER	AIRFEED	OBSOLETE
-2	AMP-O-LECTRIC	AIRFEED	

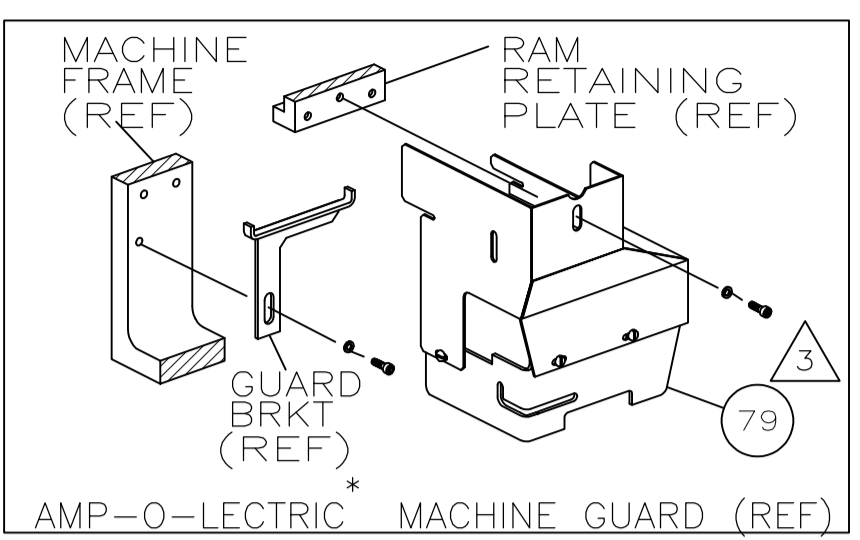
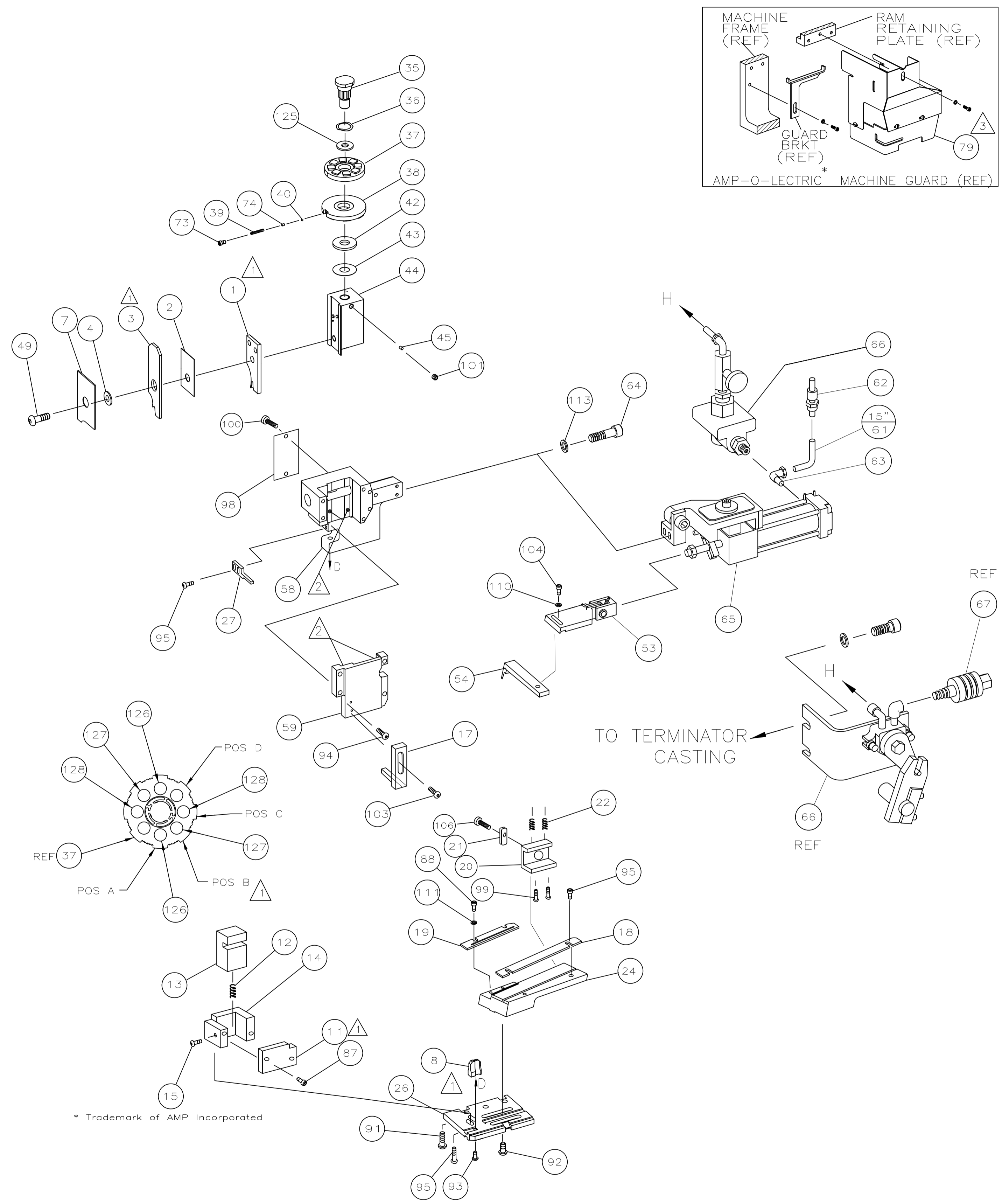

- 1 RECOMMENDED SPARE PARTS.
- 2 GREASE LIGHTLY.
- 3 GUARD MUST BE IN PLACE WHEN OPERATING APPLICATOR IN AMP-O-LECTRIC MACHINE.
- 4 SEE DRAWING FOR COMPONENTS

TERMINAL NAME:		CRIMPING DATA			
MT-EDGE-CRIMP-CONTACT		926917			
PAD LTR	CRIMP HEIGHT	WIRE SIZE			
A	.054 ±.002	1.00 MM ²			
B	.051 ±.002	.75 MM ²			
C	.047 ±.002	.50 MM ² (20)			
D	NOT USED				
CRIMP	SIZE	TYPE	RANGE		
WIRE	.080	F	.50-1.00 MM ²		
INSUL	.110	0			
FEED	.550	APPL INST	SET UP GAGE	LAYOUT	
WIRE STRIP LENGTH		A18039		L1509	

QTY	REV	DESCRIPTION	ITEM NO
1	1	986950-1	125
2	2	2-354779-8	128
2	2	2-354779-0	127
2	2	1-354779-4	126
1	1	22353-8	106
2	2	21024-5	113
2	2	21024-2	112
1	3	21024-4	110
1	1	2-22603-1	104
2	3	2-21002-1	103
1	1	21009-2	101
2	2	21017-2	100
2	2	3-21002-0	99
1	1	461264-1	98
6	8	2-21002-2	95
4	4	3-21002-0	94
1	1	22733-8	93
4	4	3-21002-3	92
3	3	2-22733-8	91
2	2	1-21000-5	88
2	2	1-21000-8	87
1	1	1-455750-5	79
1	1	690603-1	74
1	1	23030-1	73
-2	-1	U/M	

REV	DESCRIPTION	DATE	BY
70	VALVE, SHUT OFF		
69	VALVE ASSY		
68	AIR FEED ASSY		
67	SCR,SHC(10-32x1.25)AIR FD ASSY		
66	ELBOW, TUBING 1/8NPT - 1/4 T		
65	QUICK DISCONNECT		
64	TUBING, POLY-FLO 1/4 DIA		
63	CAP, RAM		
62	HOUSING		
61			
60			
59	PAWL, FEED		
58	HOLDER, FEED FINGER		
57			
56			
55			
54	1-694433-3		
53	461062-1		
52			
51			
50	7-21002-9		
49	BOLT, CRIMPER(5/16-24x1.00)		
48			
47			
46			
45	690191-1		
44	679405-1		
43	690125-1		
42	690124-1		
41			
40	23241-6		
39	690170-1		
38	690142-1		
37	354777-1		
36	22480-5		
35	690212-1		
34			
33			
32			
31			
30			
29			
28			
27	679380-1		
26	679352-1		
25			
24	679340-1		
23			
22	1-22284-0		
21	240793-1		
20	240792-1		
19	679279-1		
18	679379-1		
17	679428-1		
16			
15	690461-2		
14	354906-1		
13	679296-1		
12	4-22280-8		
11	354905-1		
10			
9			
8	679328-1		
7	679327-1		
6			
5			
4	1-238011-8		
3	679324-1		
2	455888-8		
1	679325-1		
-2	-1	U/M	

A

A

THIS DRAWING IS A CONTROLLED DOCUMENT.

DIMENSIONS: INCHES		TOLERANCES UNLESS OTHERWISE SPECIFIED:	
0 PLC	± .005	0.000000	A1
1 PLC	± .005	00779	680008
2 PLC	± .005	Customer Accessible Production Drawing	
3 PLC	± .005	Customer Accessible Production Drawing	
4 PLC	± .005	Customer Accessible Production Drawing	
ANGLES	± .005	Customer Accessible Production Drawing	

Customer Accessible Production Drawing



END FEED HDM APPLICATOR

Customer Accessible Production Drawing