

PART NUMBER	REVISION	DESCRIPTION	FEED TYPE
2266110-1	L	FINE CRIMP HEIGHT ADJUST	MECHANICAL
2266110-2	L	FINE CRIMP HEIGHT ADJUST	PNEUMATIC
5-2266110-1	L	SEAL STRIPPER CRIMPER TERMINATING UNIT	MECHANICAL
5-2266110-2	L	SEAL STRIPPER CRIMPER TERMINATING UNIT	PNEUMATIC
7-2266110-1	L	MECHANICAL AND CRIMP TOOLING KIT	MECHANICAL
7-2266110-2	L	PNEUMATIC AND CRIMP TOOLING KIT	PNEUMATIC
7-2266110-7	H	CRIMP TOOLING KIT	-
7-2266110-8	C	APPLICATOR CONVERSION KIT	-

ATLANTIC VERSION TERMINATOR INTERFACE ADAPTER

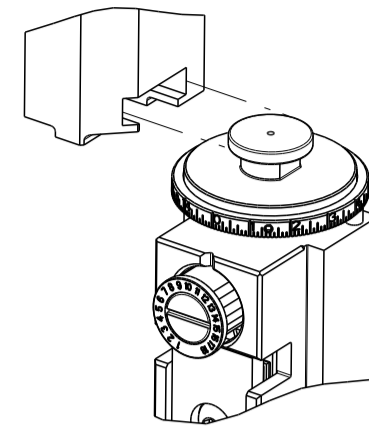

APPLICATOR DATA		
CRIMP	SIZE	TYPE
WIRE	1.88 mm [.074]	F
INSUL	1.73 mm [.068]	O

APPLICATOR CONVERSION KITS	
PART NUMBER	INSULATION DIAMETER RANGE
7-2266110-8	Ø 1.68-2.39mm [.066-.094]
7-2266111-8	Ø 1.27-1.65mm [.050-.065]

TERMINAL DATA: DEUTSCH TERMINAL TE CRIMP SPECIFICATION			
TERMINAL NAME: STAMPED CONTACT PIN SIZE 16			
WIRE STRIP LENGTH	INSULATION DIAMETER RANGE		
3.81-5.09 mm [.150-.200 IN]	Ø 1.68-2.39 mm [.066-.094 IN]		
TERMINAL APPLICATION SPECIFICATION	114-151000		
TERMINALS APPLIED			
TE TERMINAL	DEUTSCH TERMINAL	TE TERMINAL	DEUTSCH TERMINAL
286503-4	1060-16-0622	1-286503-6	AT60-16-0622
286503-5	1060-16-0644	1-286503-7	AT60-16-0644
286503-6	1060-16-0688		
1-286503-3	1060-16-0677		

TERMINAL DATA: DEUTSCH TERMINAL TE CRIMP SPECIFICATION			
TERMINAL NAME: STAMPED CONTACT SOCKET SIZE 16			
WIRE STRIP LENGTH	INSULATION DIAMETER RANGE		
3.81-5.09 mm [.150-.200 IN]	Ø 1.68-2.39 mm [.066-.094 IN]		
TERMINAL APPLICATION SPECIFICATION	114-151000		
TERMINALS APPLIED			
TE TERMINAL	DEUTSCH TERMINAL	TE TERMINAL	DEUTSCH TERMINAL
286504-4	1062-16-0622	286504-5	1062-16-0644
1-286504-4	1062-16-0677	286504-6	1062-16-0688

TERMINAL DATA: TE TERMINAL TE CRIMP SPECIFICATION			
TERMINAL NAME: STAMPED PIN/CONTACT SOCKET SIZE 16			
WIRE STRIP LENGTH	INSULATION DIAMETER RANGE		
3.81-5.09 mm [.150-.200 IN]	Ø 1.68-2.39 mm [.066-.094 IN]		
TERMINAL APPLICATION SPECIFICATION	114-160698		
TERMINALS APPLIED			
TE TERMINAL	TE TERMINAL	TE TERMINAL	TE TERMINAL
2500060-2	2500062-2		

WIRE SIZE	CRIMP HEIGHT mm [INCH]	CRIMP HEIGHT REFERENCE SETTING
1.00mm2	1.26+/-0.04 [.050+/- .0015]	6.6
0.75mm2	1.21+/-0.04 [.048+/- .0015]	7.0
0.50mm2	1.13+/-0.04 [.044+/- .0015]	7.8

WIRE SIZE	CRIMP HEIGHT mm [INCH]	CRIMP HEIGHT REFERENCE SETTING
16 AWG	1.27+0.03/-0.05 [.050+ .001/- .002]	6.5
1.00mm2	1.27+0.03/-0.05 [.050+ .001/- .002]	6.5
18 AWG	1.24+0.03/-0.05 [.049+ .001/- .002]	6.8
0.75mm2	1.22+0.03/-0.05 [.048+ .001/- .002]	6.9
20 AWG	1.22+0.03/-0.05 [.048+ .001/- .002]	6.9
0.50mm2	1.14+0.03/-0.05 [.045+ .001/- .002]	7.7

***WARNING**
ON INSTALLATION, SET WIRE DISC TO CRIMP HEIGHT REFERENCE SETTING FOR LARGEST WIRE SIZE. CRIMP HEIGHT REFERENCE SETTINGS GREATER THAN THE VALUE SHOWN MAY CAUSE DAMAGE TO THE CRIMP TOOLING. REFER TO THE INSTRUCTION SHEET FOR PROPER SETUP AND ADJUSTMENTS.

- 1 RECOMMENDED SPARE PARTS
- 2 REFER TO SUPPLIED INSTRUCTION SHEET FOR CLEANING, LUBRICATION AND STORAGE OF APPLICATOR.
- 3 APPLY PART NUMBER 2-23419-6 LOCTITE TO THREADS OF ITEM 242.
- 4 CRIMP HEIGHT REFERENCE SETTING WAS THE SETTING USED WHEN THE APPLICATOR WAS QUALIFIED AT THE FACTORY. ADJUSTMENT MAY BE NECESSARY WHEN RUNNING APPLICATOR IN THE FIELD.
- 5 TERMINAL LUBRICANT IS RECOMMENDED.
- 6. UNLESS SPECIFIED OTHERWISE TORQUE VALUES SHALL BE USED PER DOCUMENT, 101-35000.
- 7 SEE APPROPRIATE APPLICATOR LOG SHEETS FOR APPLIED TERMINALS AND WIRE RANGE.
- 8 DIMENSION 3.1±0.50 APPLIES TO PIN TERMINALS 1060-16-06XX
- 9 DIMENSION 7.60±0.50 APPLIES TO SOCKET TERMINALS 1062-16-06XX

LOC		DIST		REVISIONS				
P	LTN	DESCRIPTION	DATE	OWN	APVD			
J1		ECR-21-003343	18MAR2021	FZ	RK			
K		ECR-22-151720	06SEP2022	ROY	GEB			
L		ECR-23-189563	12OCT2023	TB	GB			
LI		ECR-23-193052	20NOV2023	TB	RK			

-	-	1	1	1	1	1	1	1	1-1803945-3	TONKER	300
-	-	1	1	1	1	1	1	1	1-22278-9	SPRING, COMPRESSION	299
-	-	2	2	2	2	2	2	2	4-18032-3	SCR, SET, FLT PNT, M3 X 6.0	298
-	-	1	1	1	1	1	1	1	1803944-1	SPACER, TONKER	297
-	-	-	-	1	1	-	-	-	2-1803583-1	APPLICATOR BASIC ASSEMBLY, SF	292
-	-	1	-	1	-	1	-	-	2119641-1	FEED CAM, AIR FEED	248
-	-	1	1	1	1	1	1	1	2119082-9	CAM, SNAIL, INSULATION ADJUSTMENT	244
-	-	1	1	1	1	1	1	1	2079764-1	WASHER, WAVE SPRING, CREST-TO-CREST	243
-	-	1	1	1	1	1	1	1	2119083-1	RETAINER, INSULATION DIAL	242
-	-	1	1	1	1	1	1	1	7-18023-7	SCR, SKT HD CAP M3 X 4.0	241
-	-	-	-	1	-	1	-	1	2119580-1	MECHANICAL FEED ASSEMBLY	239
-	-	1	-	1	-	1	-	-	2844940-1	AIR FEED MODULE	238
-	-	REF	REF	REF	REF	REF	REF	REF	994970-2	COUNTER, MAGNETIC	164
-	-	1	1	1	1	1	1	1	2119955-1	ASSY, LUBRICATOR, SIDE FEED	113
-	-	1	1	1	1	1	1	1	2844908-1	SCREW, LOCKING	99
-	-	1	1	1	1	1	1	1	2844907-1	POST, LOCKING	98
-	-	1	1	1	1	1	1	1	455888-4	SPACER, CRIMPER	82
1	-	-	-	-	-	-	-	-	2266110	PRINT, APPLICATOR LOG SHEET	72
-	-	1	1	1	1	1	1	1	1803607-3	DOCUMENTATION PACKAGE	71
-	-	2	2	2	2	2	2	2	2119791-5	DEPRESSOR, WIRE	70
-	-	1	1	1	1	1	1	1	2119740-1	TAG IDENTIFICATION	67
-	-	2	2	2	2	2	2	2	2168078-1	SCREW, DRIVE, RH, RoHS, 2 x .188	66
-	-	1	1	1	1	1	1	1	2168083-2	SCR, SKT HD CAP, RoHS, M4 X 8.0	60
-	-	1	1	1	1	1	1	1	5-18022-5	SCR, HEX HD CAP, M4 X 6.0	59
-	-	1	1	1	1	1	1	1	1338685-1	PAWL, FEED	56
-	-	4	4	4	4	4	4	4	2168083-3	SCR, SKT HD CAP, RoHS, M4 X 12.0	54
-	-	2	2	2	2	2	2	2	2-2168083-5	SCR, SKT HD CAP, RoHS, M4 X 14	53
-	-	1	2	1	2	1	2	1	18023-9	SCR, SKT HD CAP M4 X 6.0	49
-	-	-	1	-	1	-	1	-	2119652-1	FEED CAM, PRE FEED	48
-	-	-	1	-	1	-	1	-	2119653-1	FEED CAM, POST FEED	47
-	-	1	1	-	-	1	1	-	1803583-9	APPLICATOR BASIC ASSEMBLY, SF	46
-	-	1	1	1	1	1	1	1	1803515-1	RAM ASSEMBLY, SF ATLANTIC	44
-	-	1	1	1	1	1	1	1	1803602-1	SCR, BHSC, RoHS (M8 X 25)	41
-	-	1	1	1	1	1	1	1	2-1752356-0	SUPPORT, TERMINAL	34
-	-	2	2	2	2	2	2	2	2079383-5	SCR, BHSC, RoHS (M4 X 20)	33
-	-	2	2	2	2	2	2	2	2-2844962-6	SPACER, CYLINDRICAL, STRIP GUIDE	30
-	-	1	1	1	1	1	1	1	2844992-1	ASSEMBLY, STRIP GUIDE	29
-	-	1	1	1	1	1	1	1	1320928-2	STRIP GUIDE	24
-	-	1	1	-	-	1	1	1	2168083-2	SCR, SKT HD CAP, RoHS, M4 X 8.0	21
-	-	2	2	1	1	2	2	2	1-18028-2	WASHER, FLAT, REG M4	20
-	-	1	1	-	-	1	1	1	2119533-1	STRIPPER, SIDE FEED	19
-	-	1	1	1	1	1	1	1	2119806-1	INSERT, SHEAR	13
-	-	1	1	1	1	1	1	1	3-22280-3	SPRING, COMPRESSION	12
-	-	1	1	1	1	1	1	1	1-356885-4	STOP, SHEAR	11
-	-	1	1	1	1	1	1	1	2119805-1	SHEAR HOLDER, FRONT	10
-	-	1	1	1	1	1	1	1	1803095-6	FLOATING SHEAR, FRONT	9
1	1	2	2	1	1	1	1	1	1803293-6	ANVIL, COMBINATION DEUTSCH STYLE	8
-	-	1	1	1	1	1	1	1	4-240641-0	SPACER	7
-	-	-	-	-	-	-	-	-	-	-	6
-	-	1	1	1	1	1	1	1	1-2119757-0	DEPRESSOR, SHEAR	5
-	-	1	1	1	1	1	1	1	238011-9	BLOCK, CRIMPER SPACER	4
1	1	2	2	1	1	1	1	1	1803019-7	CRIMPER, INSULATION O	3
1	-	1	1	1	1	1	1	1	455888-5	SPACER, CRIMPER	2
1	-	1	2	2	1	1	1	1	4-1633713-1	CRIMPER, WIRE PREMIUM	1

DIMENSIONS:		TOLERANCES UNLESS OTHERWISE SPECIFIED:		MATERIAL:		FINISH:		WEIGHT:		SCALE:	
mm	0 PLC ±	1 PLC ±	2 PLC ±	3 PLC ±	4 PLC ±	ANGLES ±	FINISH			1:2	SHEET 1 OF 4
MATERIAL				FINISH				WEIGHT		SCALE	
Customer Accessible Production Drawing				SCALE				SHEET		REV	

LOC	DIST	REVISIONS					
A	66	P	LTN	DESCRIPTION	DATE	OWN	APVD
		-		SEE SHEET 1			

FEED TYPE MECHANICAL

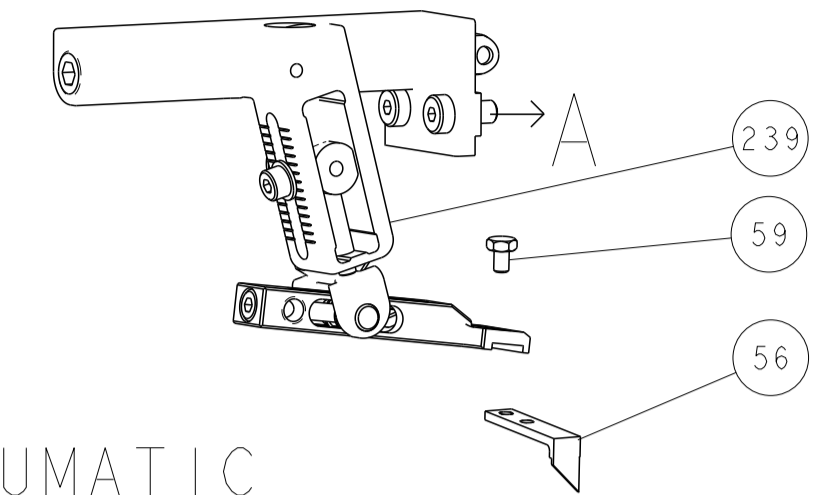

PNEUMATIC

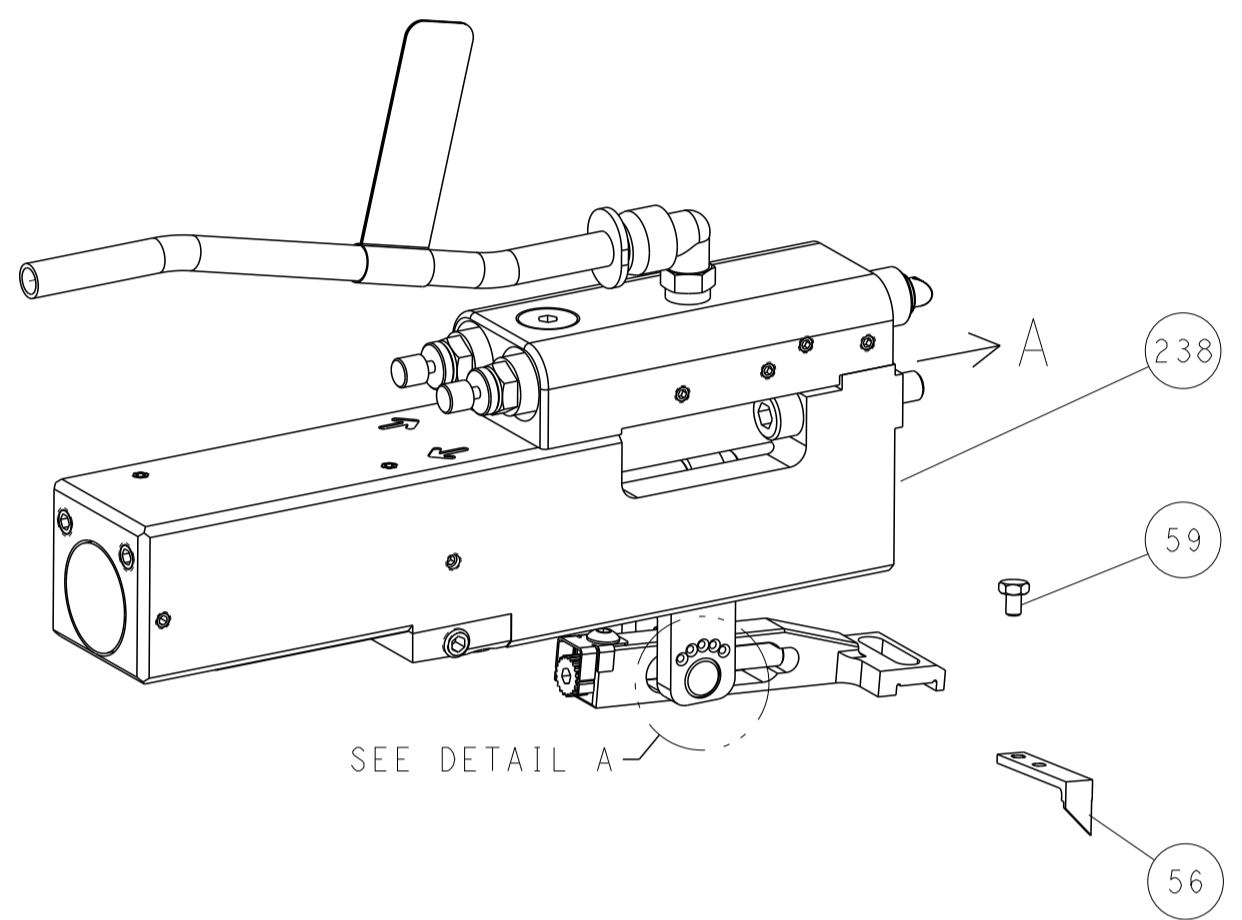

FEED SPRING SETTING POSITION (SHOWN FROM REAR SIDE)



DETAIL A

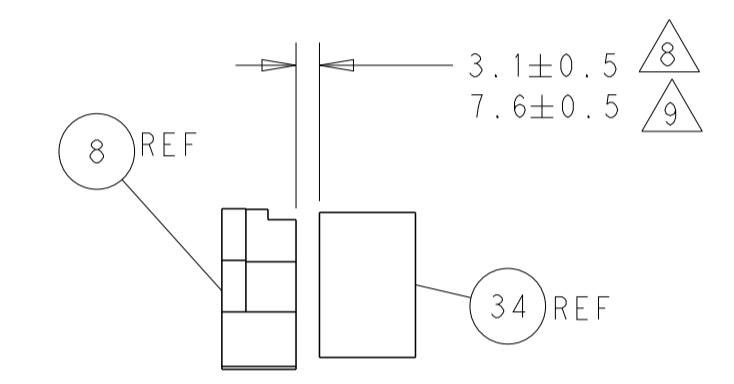
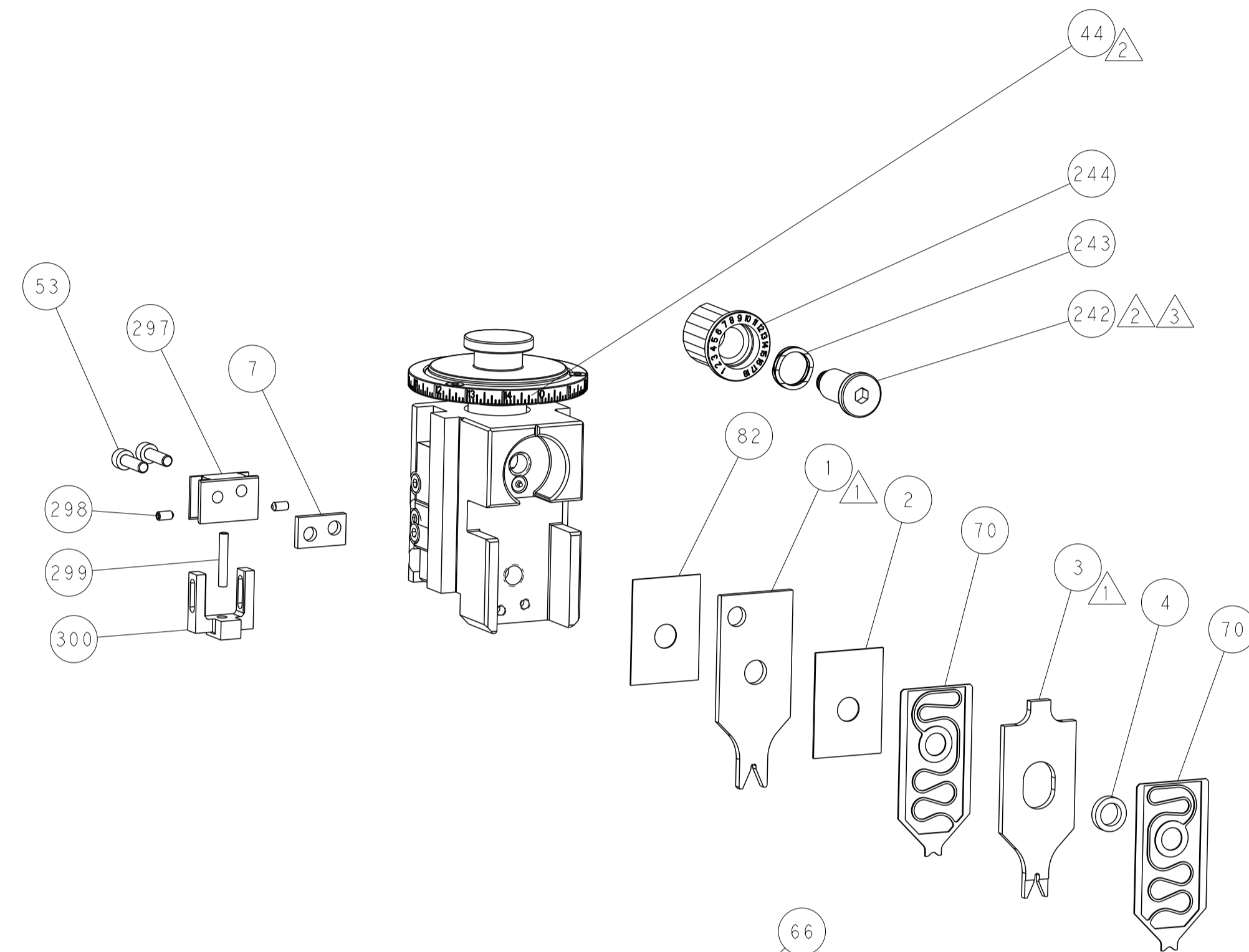

TERMINAL SUPPORT LOCATION

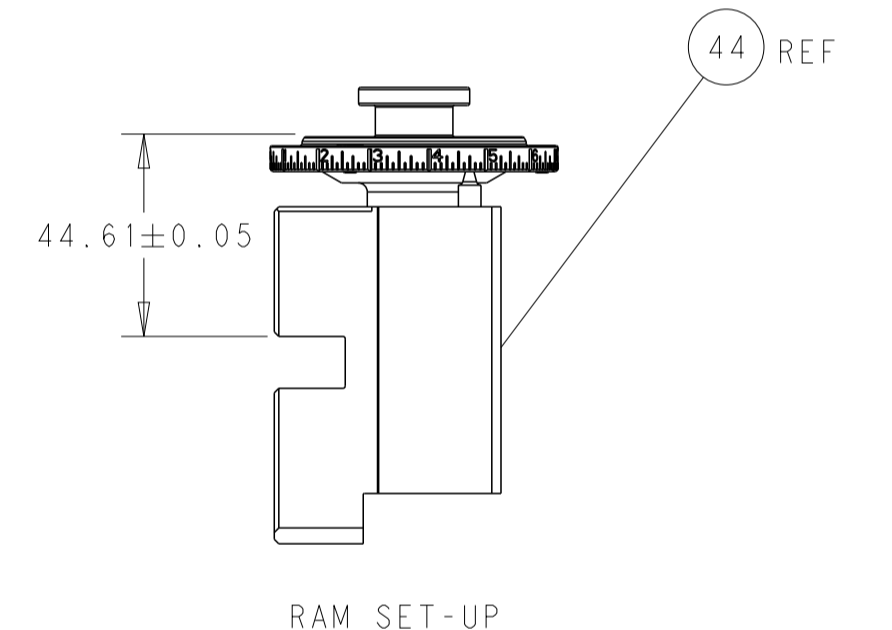

RAM SET-UP

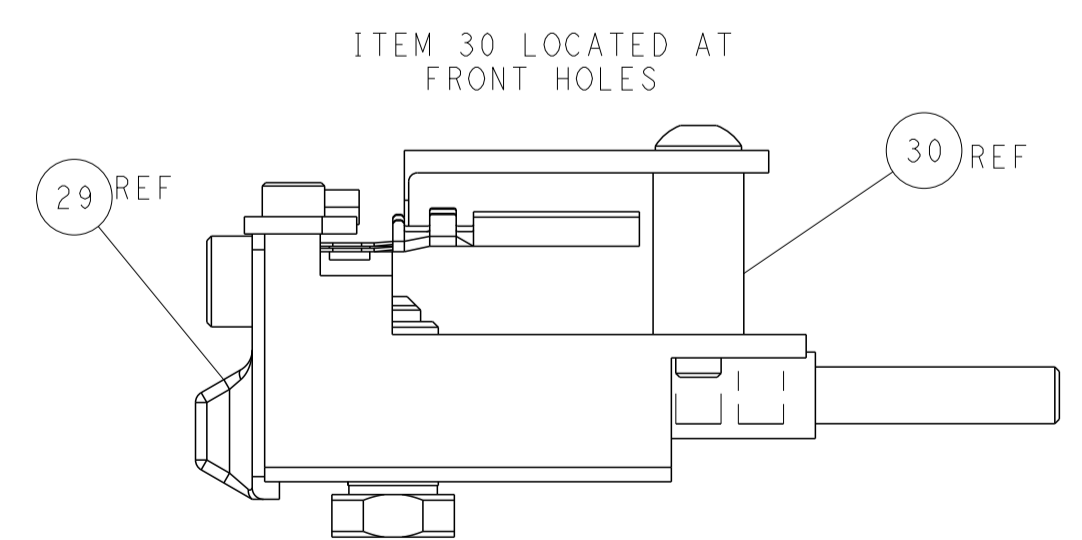
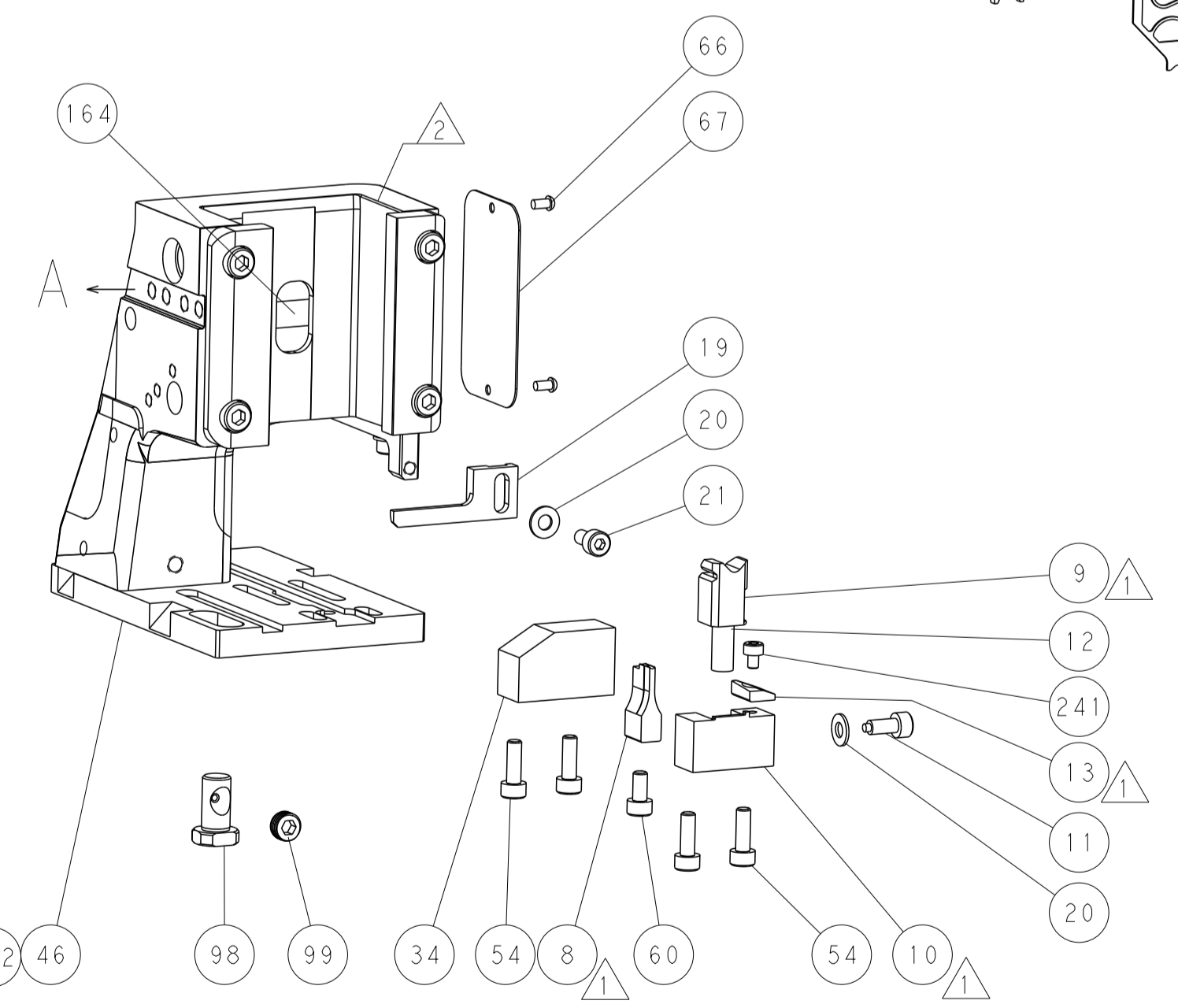
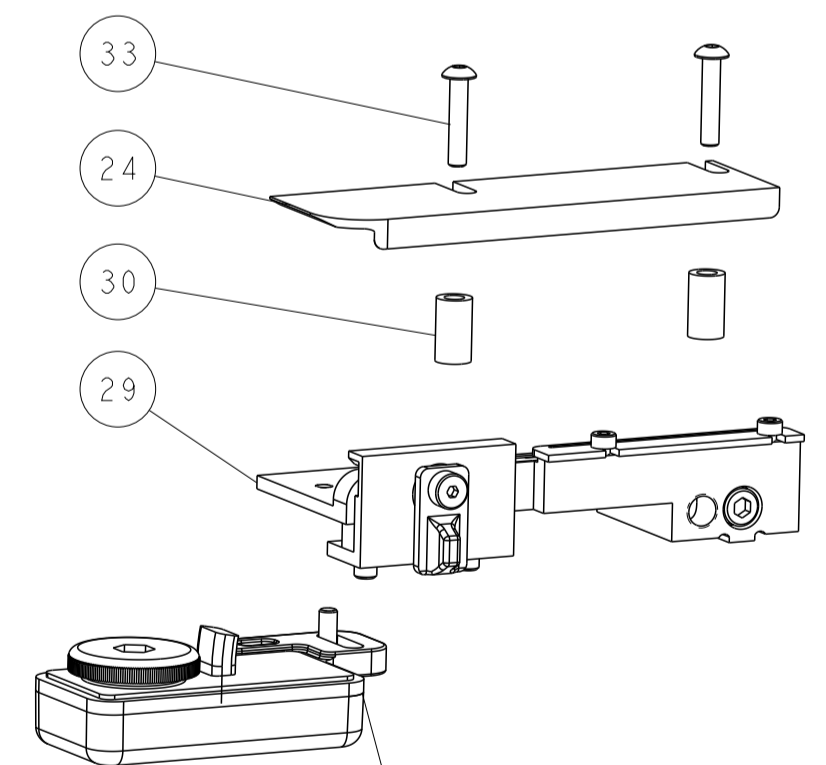

FEED TRACK POSITION GUIDE BY INSULATION BARREL

CAM POSITIONS

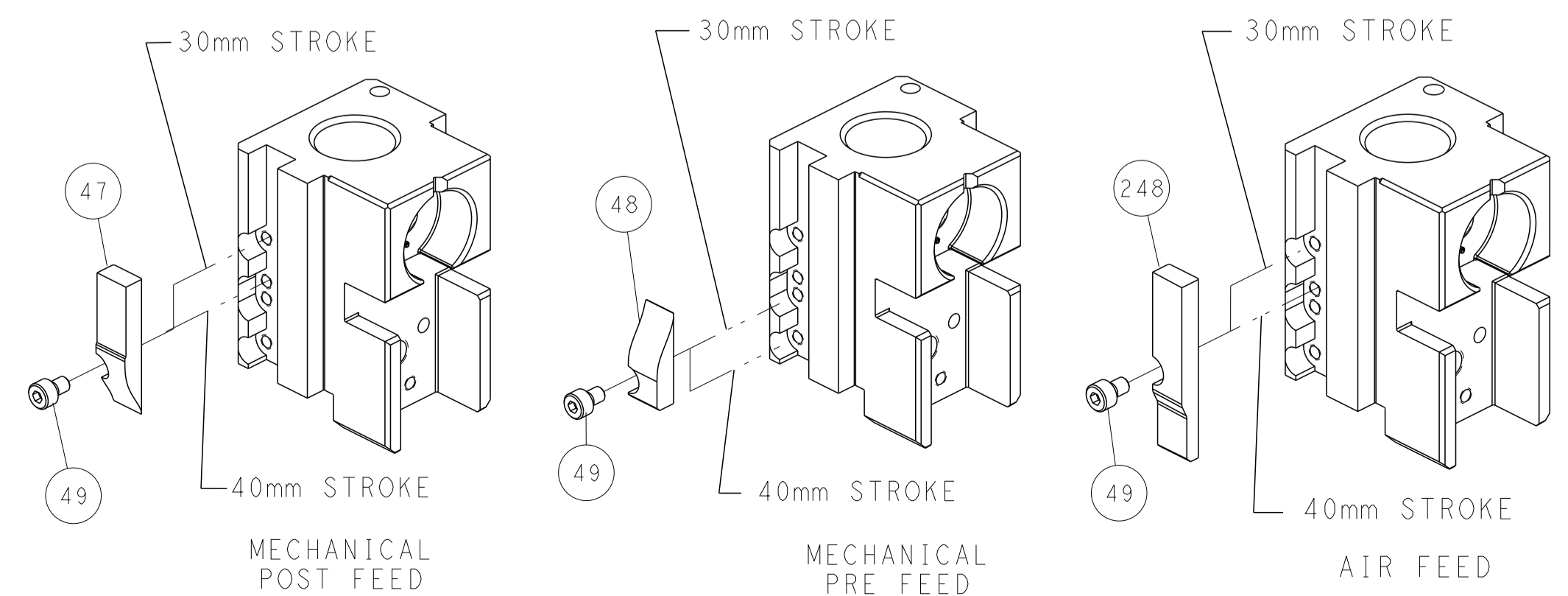

DIMENSIONS: mm 		TOLERANCES UNLESS OTHERWISE SPECIFIED: 0 PLC ± 1 PLC ± 2 PLC ± 3 PLC ± 4 PLC ± ANGLES ± FINISH		DWN R. KNEPPER 08-Oct-13 CHK G. BAILEY 08-Oct-13 APVD M. CLIFFORD 08-Oct-13 NAME Ocean Side Feed Applicator SIZE CAGE CODE DRAWING NO. RESTRICTED TO A1 00779 C=2266110 Customer Accessible Production Drawing SCALE 1:2 SHEET 2 OF 4 REV L1	
MATERIAL:		WEIGHT:		DATE: 08-Oct-13 HARRISBURG, PA 17105-3608	