

| PART NUMBER | REVISION | DESCRIPTION | FEED TYPE |
|-------------|----------|----------------------------------|------------|
| 2151997-1 | C | FINE CRIMP HEIGHT ADJUST | MECHANICAL |
| 2151997-2 | C | FINE CRIMP HEIGHT ADJUST | PNEUMATIC |
| 7-2151997-1 | C | MECHANICAL AND CRIMP TOOLING KIT | MECHANICAL |
| 7-2151997-2 | C | PNEUMATIC AND CRIMP TOOLING KIT | PNEUMATIC |
| 7-2151997-7 | A | CRIMP TOOLING KIT | - |

ATLANTIC VERSION TERMINATOR INTERFACE ADAPTER



| APPLICATOR DATA | | |
|-----------------|----------------|------|
| CRIMP | SIZE | TYPE |
| WIRE | 2.29 mm [.090] | F |
| INSUL | 3.30 mm [.130] | F |

APPLICATOR INSTRUCTIONS 408-35042

| TERMINAL DATA: TE TERMINAL | | TE CRIMP SPECIFICATION | |
|--|-------------|------------------------------|-------------|
| TERMINAL NAME: PIN AND SOCKET MATE-N-LOK | | | |
| WIRE STRIP LENGTH | | INSULATION DIAMETER RANGE | |
| 3.90-4.70 mm [.154-.185 IN] | | Ø2.54-3.81 mm [.100-.150 IN] | |
| TERMINAL APPLICATION SPECIFICATION | 114-3118 | | |
| TERMINALS APPLIED | | | |
| TE TERMINAL | TE TERMINAL | TE TERMINAL | TE TERMINAL |
| 163302-5 | 163302-7 | 163302-9 | 163303-6 |
| 163302-6 | 163302-8 | | 163303-8 |

| WIRE SIZE | CRIMP HEIGHT mm [INCH] | CRIMP HEIGHT REFERENCE SETTING |
|-----------|-------------------------------|--------------------------------|
| 2.50mm2 | 1.60 +/- 0.05 [.063 +/- .002] | 5.9 |
| 1.50mm2 | 1.60 +/- 0.05 [.063 +/- .002] | 6 |
| 1.00mm2 | 1.45 +/- 0.05 [.057 +/- .002] | 7.6 |

- 1 RECOMMENDED SPARE PARTS
- 2 REFER TO SUPPLIED INSTRUCTION SHEET FOR CLEANING, LUBRICATION AND STORAGE OF APPLICATOR.
- 3 APPLY PART NUMBER 2-23419-6 LOCTITE TO THREADS OF ITEM 242.
- 4 CRIMP HEIGHT REFERENCE SETTING WAS THE SETTING USED WHEN THE APPLICATOR WAS QUALIFIED AT THE FACTORY. ADJUSTMENT MAY BE NECESSARY WHEN RUNNING APPLICATOR IN THE FIELD.
- 5. UNLESS SPECIFIED OTHERWISE TORQUE VALUES SHALL BE USED PER DOCUMENT, 101-35000.

***WARNING**
ON INSTALLATION, SET WIRE DISC TO CRIMP HEIGHT REFERENCE SETTING FOR LARGEST WIRE SIZE. CRIMP HEIGHT REFERENCE SETTINGS GREATER THAN THE VALUE SHOWN MAY CAUSE DAMAGE TO THE CRIMP TOOLING, REFER TO THE INSTRUCTION SHEET FOR PROPER SETUP AND ADJUSTMENTS.

ATLANTIC VERSION
Shown on sheets 1 of 4 & 2 of 4
(Pacific version shown on sheets 3 of 4 & 4 of 4)

| LOC | DIST | REVISIONS | | | | | |
|-----|------|-----------|-----|---------------|-----------|-----|------|
| A | 66 | P | LTN | DESCRIPTION | DATE | OWN | APVD |
| | | A | | RELEASED | 27AUG2013 | GH | TE |
| | | A1 | | ECR-14-000858 | 20JAN2014 | YY | UG |
| | | B | | ECR-18-014847 | 11OCT2018 | MS | TE |
| | | C | | ECR-19-007289 | 07MAY2019 | TB | GB |

| | | | | | | | | |
|---|-----|-----|-----|-----|-------------|-------------------------------------|-------------------------------|---|
| - | 1 | - | 1 | - | 2119640-1 | PUSH ROD, AIR FEED | 250 | |
| - | 1 | - | 1 | - | 1803259-1 | BUSHING, FLANGED | 249 | |
| - | 1 | - | 1 | - | 2119641-1 | FEED CAM, AIR FEED | 248 | |
| - | 1 | 1 | 1 | 1 | 2119082-9 | CAM, SNAIL, INSULATION ADJUSTMENT | 244 | |
| - | 1 | 1 | 1 | 1 | 2079764-1 | WASHER, WAVE SPRING, CREST-TO-CREST | 243 | |
| - | 1 | 1 | 1 | 1 | 2119083-1 | RETAINER, INSULATION DIAL | 242 | |
| - | 1 | 1 | 1 | 1 | 7-18023-7 | SCR, SKT HD CAP M3 X 4.0 | 241 | |
| - | - | 1 | - | 1 | 2119580-1 | MECHANICAL FEED ASSEMBLY | 239 | |
| - | 1 | - | 1 | - | 2063440-1 | AIR FEED MODULE | 238 | |
| - | 2 | - | 2 | - | 21045-3 | RING, RETAIN, EXTERN, 3/16 CRESCENT | 172 | |
| - | REF | REF | REF | REF | 994970-2 | COUNTER, MAGNETIC | 164 | |
| - | 1 | - | 1 | - | 240638-1 | SPRING, FEED FINGER | 163 | |
| - | 1 | - | 1 | - | 3-23627-7 | PIN, RETAIN, GRVD, 3/16 X .854 | 137 | |
| - | 1 | - | 1 | - | 2119799-1 | HOLDER, FEED FINGER, AF | 136 | |
| - | 1 | 1 | 1 | 1 | 2844908-1 | SCREW, LOCKING | 99 | |
| - | 1 | 1 | 1 | 1 | 2844907-1 | POST, LOCKING | 98 | |
| - | 1 | 1 | 1 | 1 | 455888-5 | SPACER, CRIMPER | 82 | |
| - | 1 | 1 | 1 | 1 | 1803607-1 | DOCUMENTATION PACKAGE | 71 | |
| - | 1 | 1 | 1 | 1 | 2119791-5 | DEPRESSOR, WIRE | 70 | |
| - | 1 | 1 | 1 | 1 | 2119943-1 | WASHER, SPACER | 69 | |
| - | 1 | 1 | 1 | 1 | 2119740-1 | TAG, IDENTIFICATION | 67 | |
| - | 2 | 2 | 2 | 2 | 2168078-1 | SCREW, DRIVE, RH, RoHS, 2 x .188 | 66 | |
| - | 1 | 1 | 1 | 1 | 2168083-2 | SCR, SKT HD CAP, RoHS, M4 X 8.0 | 60 | |
| - | 1 | 1 | 1 | 1 | 5-18022-5 | SCR, HEX HD CAP, M4 X 6.0 | 59 | |
| - | 1 | 1 | 1 | 1 | 1338685-1 | PAWL, FEED | 56 | |
| - | 4 | 4 | 4 | 4 | 2168083-3 | SCR, SKT HD CAP, RoHS, M4 X 12.0 | 54 | |
| - | 2 | 2 | 2 | 2 | 1-2168083-0 | SCR, SKT HD CAP, RoHS, M4 X 10 | 53 | |
| - | 1 | 1 | 1 | 1 | 5018030-1 | NUT, HEX, REG, RoHS, M3 | 52 | |
| - | 1 | 1 | 1 | 1 | 811242-5 | BUMPER, HOLD DOWN | 51 | |
| - | 1 | 1 | 1 | 1 | 690753-2 | SPACER, TONKER | 50 | |
| - | 1 | 2 | 1 | 2 | 18023-9 | SCR, SKT HD CAP M4 X 6.0 | 49 | |
| - | - | 1 | - | 1 | 2119652-1 | FEED CAM, PRE FEED | 48 | |
| - | - | 1 | - | 1 | 2119653-1 | FEED CAM, POST FEED | 47 | |
| - | 1 | 1 | 1 | 1 | 1803583-9 | APPLICATOR BASIC ASSEMBLY, SF | 46 | |
| - | 1 | 1 | 1 | 1 | 1803515-1 | RAM ASSEMBLY, SF ATLANTIC | 44 | |
| - | 1 | 1 | 1 | 1 | 1803602-1 | SCR, BHSC, RoHS (M8 X 25) | 41 | |
| - | 1 | 1 | 1 | 1 | 1752356-1 | SUPPORT, TERMINAL | 34 | |
| - | 2 | 2 | 2 | 2 | 2079383-5 | SCR, BHSC, RoHS (M4 X 20) | 33 | |
| - | 2 | 2 | 2 | 2 | 3-2844962-0 | SPACER, CYLINDRICAL, STRIP GUIDE | 30 | |
| - | 1 | 1 | 1 | 1 | 2844992-1 | ASSEMBLY, STRIP GUIDE | 29 | |
| - | 1 | 1 | 1 | 1 | 455888-3 | SPACER, CRIMPER | 28 | |
| - | 1 | 1 | 1 | 1 | 1320928-2 | STRIP GUIDE | 24 | |
| - | 1 | 1 | 1 | 1 | 2168083-2 | SCR, SKT HD CAP, RoHS, M4 X 8.0 | 21 | |
| - | 2 | 2 | 2 | 2 | 1-18028-2 | WASHER, FLAT, REG M4 | 20 | |
| - | 1 | 1 | 1 | 1 | 2119533-1 | STRIPPER, SIDE FEED | 19 | |
| - | 1 | 1 | 1 | 1 | 2119806-1 | INSERT, SHEAR | 13 | |
| - | 1 | 1 | 1 | 1 | 3-22280-3 | SPRING, COMPRESSION | 12 | |
| - | 1 | 1 | 1 | 1 | 1-356885-4 | STOP, SHEAR | 11 | |
| - | 1 | 1 | 1 | 1 | 2119805-1 | SHEAR HOLDER, FRONT | 10 | |
| - | 1 | 1 | 1 | 1 | 1803095-1 | FLOATING SHEAR, FRONT | 9 | |
| - | 1 | 2 | 2 | 1 | 1 | 3-1333225-4 | ANVIL, COMBINATION | 8 |
| - | - | - | - | - | - | - | 7 | |
| - | - | - | - | - | - | - | 6 | |
| - | 1 | 1 | 1 | 1 | 1-2119757-0 | DEPRESSOR, SHEAR | 5 | |
| - | 1 | 1 | 1 | 1 | 238011-7 | BLOCK, CRIMPER SPACER | 4 | |
| - | 1 | 2 | 2 | 1 | 1 | 2119582-1 | CRIMPER, INSULATION F PREMIUM | 3 |
| - | 1 | 1 | 1 | 1 | 1 | 455888-2 | SPACER, CRIMPER | 2 |
| - | 1 | 2 | 2 | 1 | 1 | 5-456406-9 | CRIMPER, WIRE PREMIUM | 1 |

| DIMENSIONS: | | TOLERANCES UNLESS OTHERWISE SPECIFIED: | | DRAWING NO | | RESTRICTED TO | |
|--|---------|--|---------|------------|--------------|---------------|----------|
| mm | 0 PLC ± | 1 PLC ± | 2 PLC ± | 3 PLC ± | 4 PLC ± | ANGLES ± | FINISH ± |
| MATERIAL | | | | WEIGHT | SCALE | SHEET | REV |
| Customer Accessible Production Drawing | | | | SCALE 1:2 | SHEET 1 of 4 | REV C | |

| LOC | DIST | REV | DATE | BY | APPV |
|-----|------|-----|------|----|------|
| A | 66 | | | | |
| | | | | | |
| | | | | | |

FEED TYPE MECHANICAL

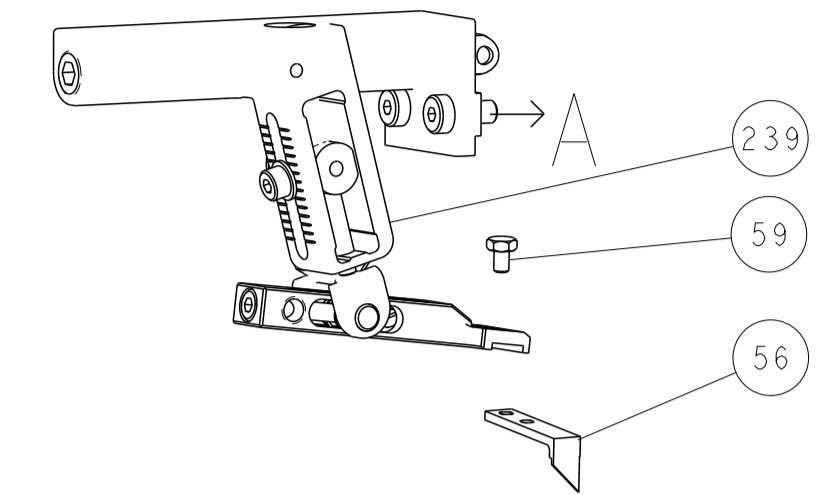

PNEUMATIC

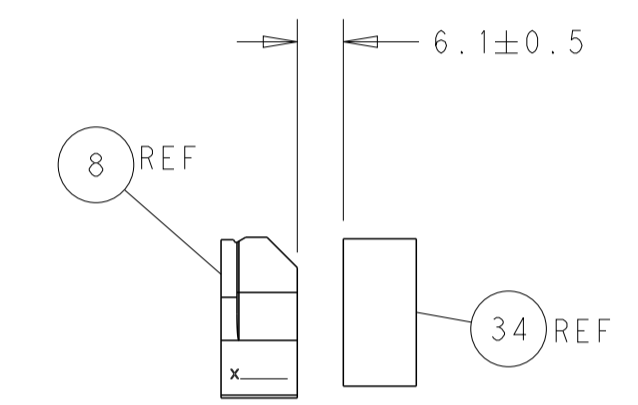
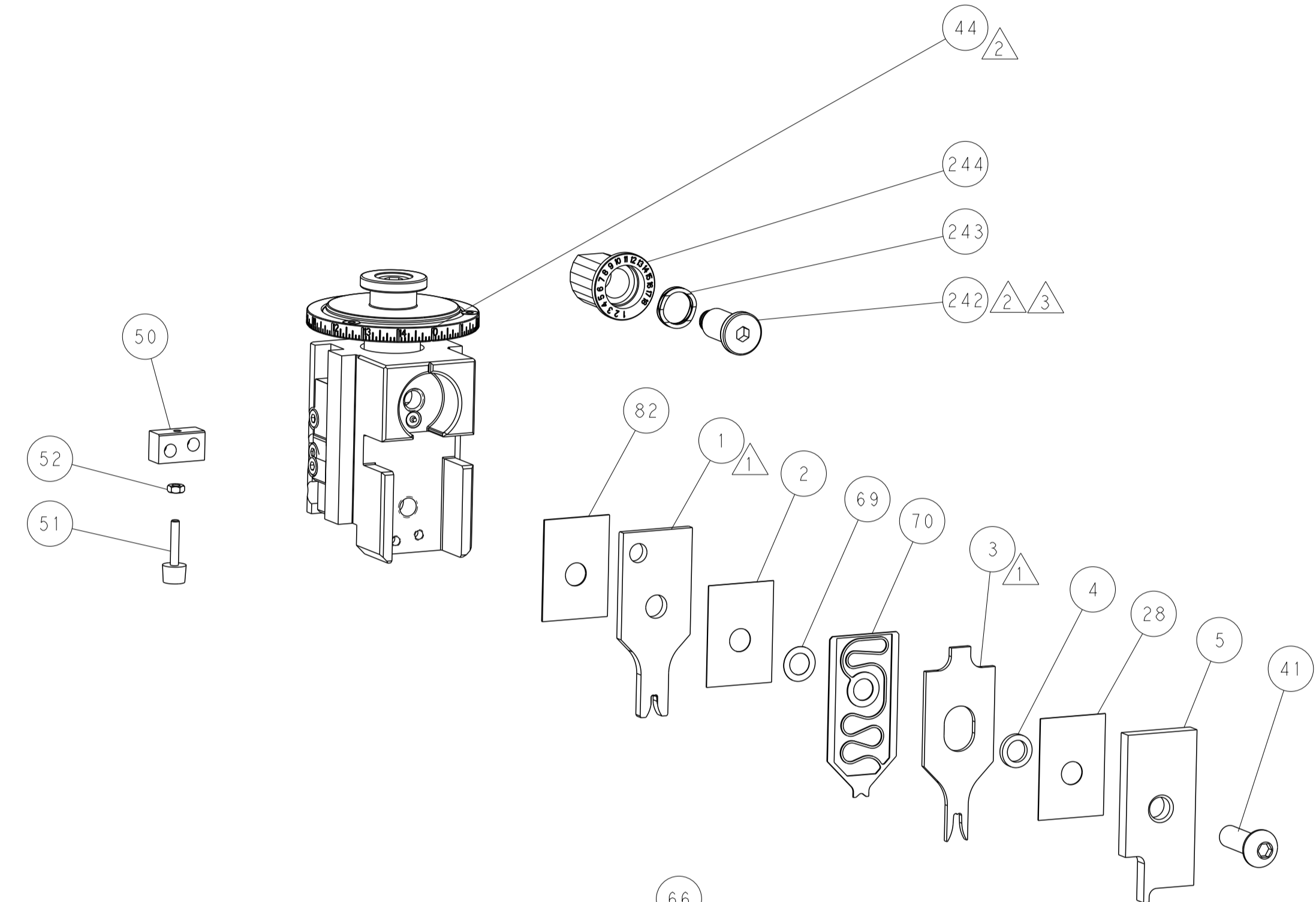
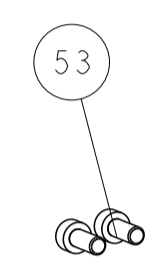
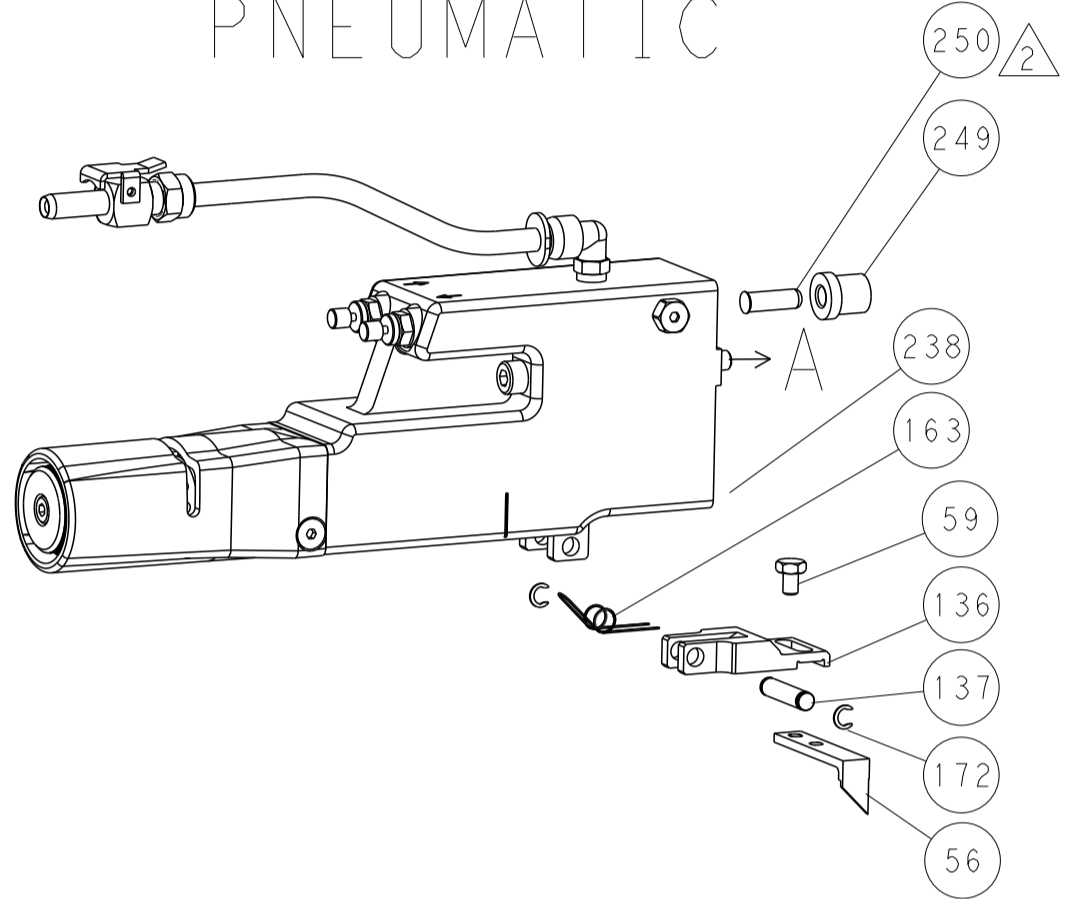

TERMINAL SUPPORT LOCATION

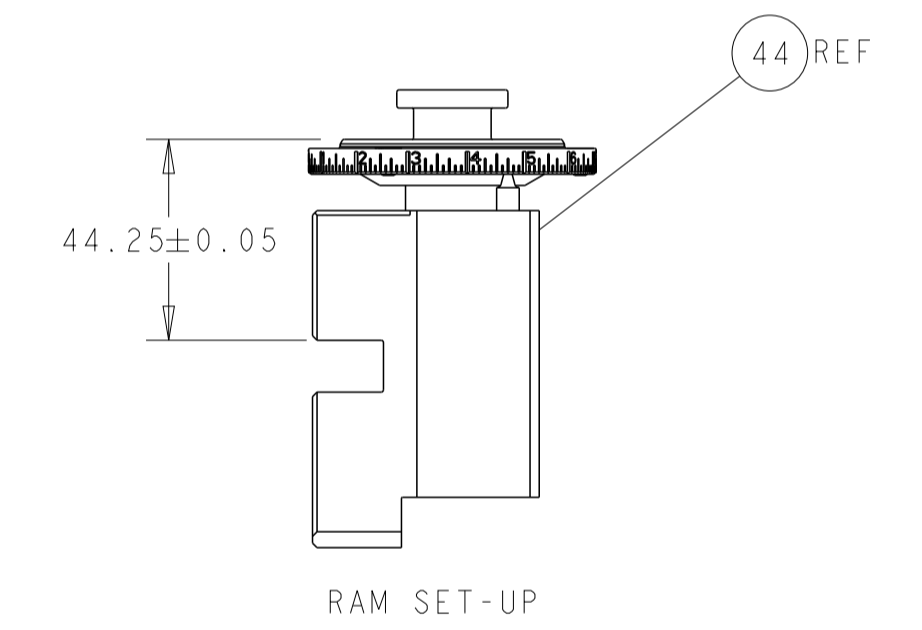

RAM SET-UP

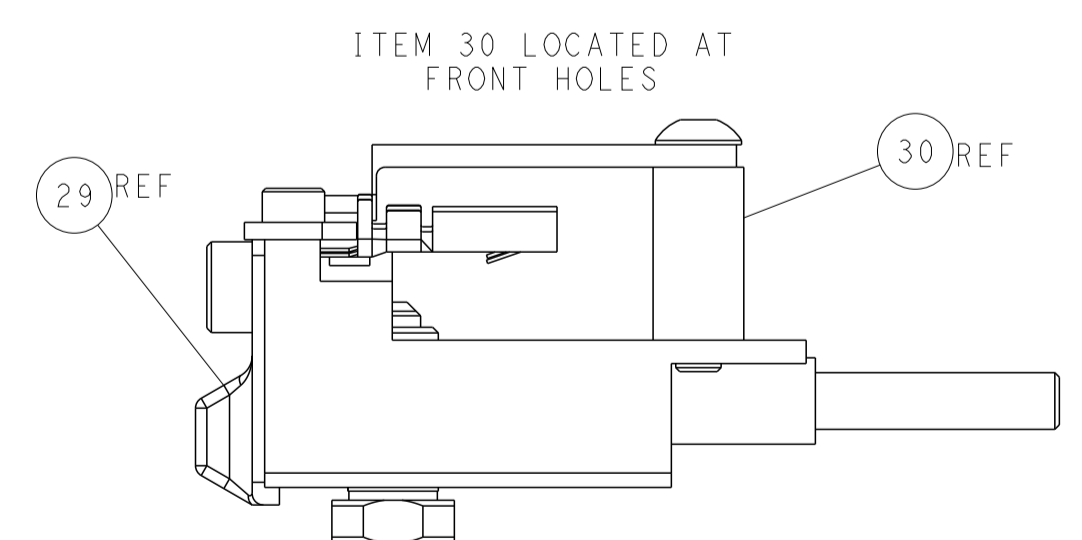
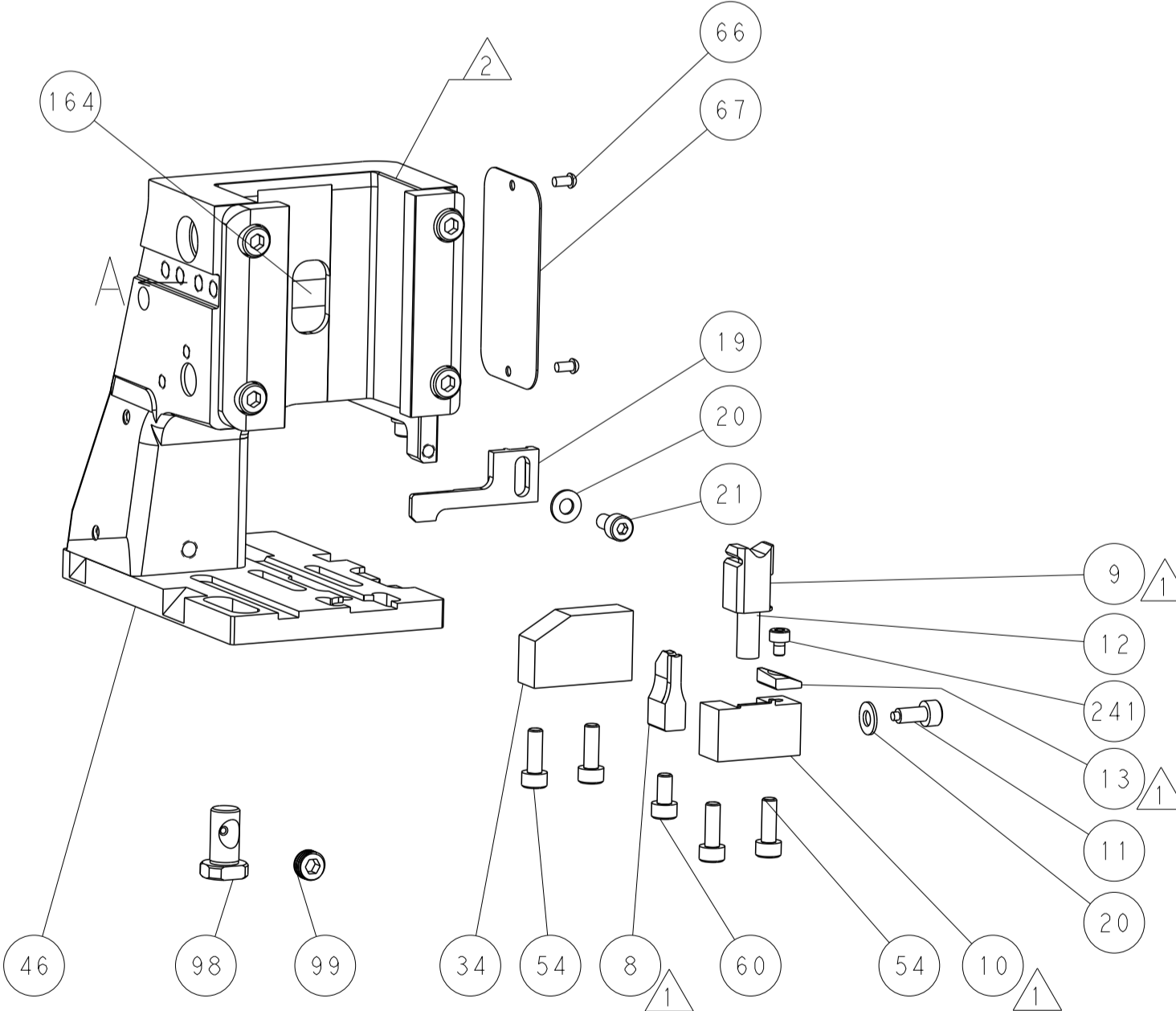
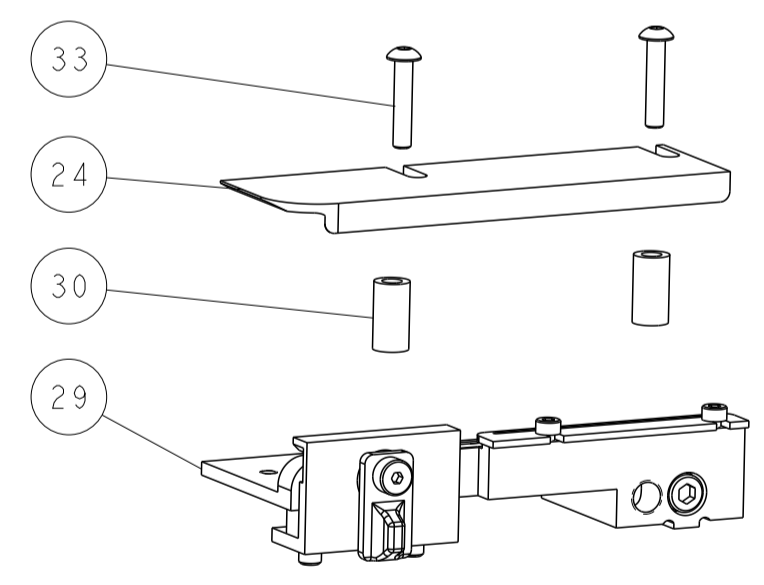

FEED TRACK POSITION GUIDE BY INSULATION BARREL

CAM POSITIONS

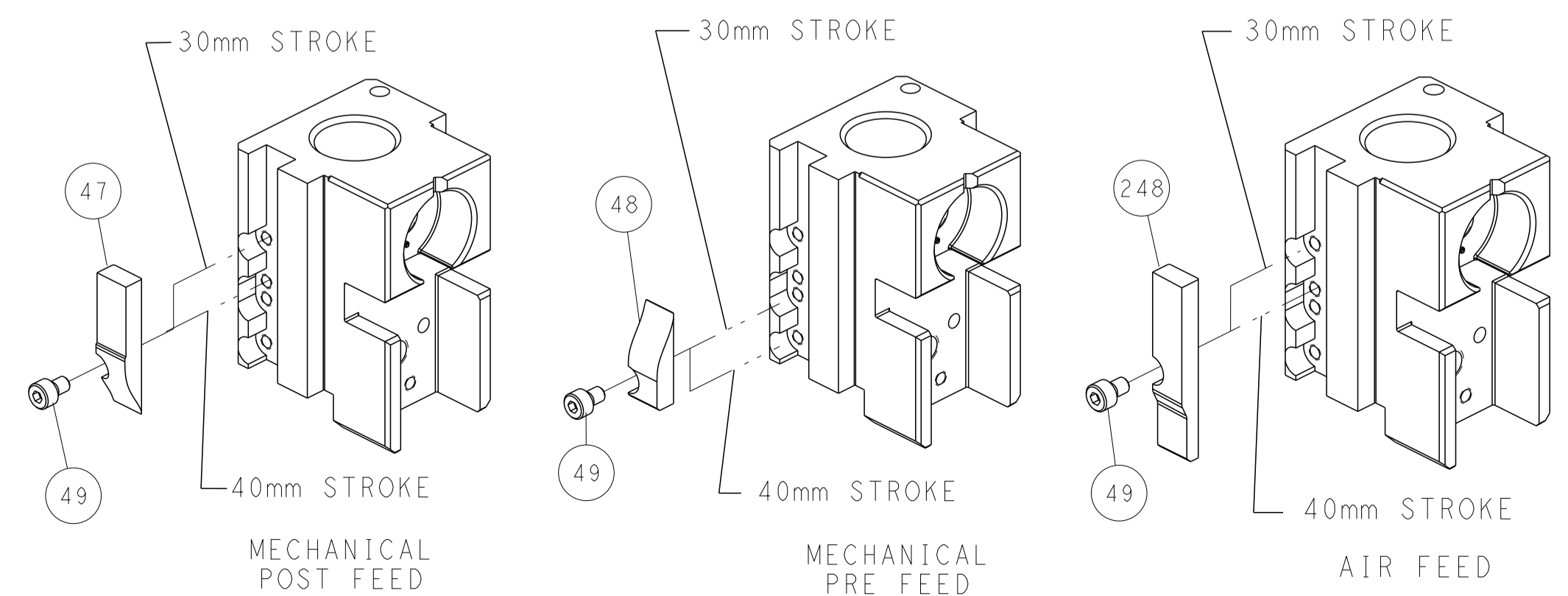

ATLANTIC VERSION
 Shown on sheets 1 of 4 & 2 of 4
 (Pacific version shown on sheets 3 of 4 & 4 of 4)

| | | | | | | | | | |
|--------------------|--|---|--|--|--|---|--|---|--|
| DIMENSIONS: mm | | TOLERANCES UNLESS OTHERWISE SPECIFIED: 0 PLC ± 1 PLC ± 2 PLC ± 3 PLC ± 4 PLC ± ANGLES ± | | DWN: HOFFNER 24JULY2013 CHK: T. ELBIN 25JULY2013 APVD: T. ELBIN 25JULY2013 PRODUCT SPEC APPLICATION SPEC WEIGHT Customer Accessible Production Drawing | | NAME: Ocean Side Feed Applicator SIZE: A1 CAGE CODE: 00779 DRAWING NO: 2151997 SCALE: 1:2 | | RESTRICTED TO: - SHEET 2 OF 4 REV C | |
|--------------------|--|---|--|--|--|---|--|---|--|

| PART NUMBER | REVISION | DESCRIPTION | FEED TYPE |
|-------------|----------|--------------------------|------------|
| 2-2151997-1 | C | FINE CRIMP HEIGHT ADJUST | MECHANICAL |
| 2-2151997-2 | C | FINE CRIMP HEIGHT ADJUST | PNEUMATIC |
| 7-2151997-7 | A | CRIMP TOOLING KIT | - |

PACIFIC VERSION TERMINATOR
 INTERFACE ADAPTER



| APPLICATOR DATA | | |
|-----------------|----------------|------|
| CRIMP | SIZE | TYPE |
| WIRE | 2.29 mm [.090] | F |
| INSUL | 3.30 mm [.130] | F |

APPLICATOR INSTRUCTIONS
 408-35042

| TERMINAL DATA: TE TERMINAL | | TE CRIMP SPECIFICATION | |
|--|-------------|------------------------------|-------------|
| TERMINAL NAME: PIN AND SOCKET MATE-N-LOK | | | |
| WIRE STRIP LENGTH | | INSULATION DIAMETER RANGE | |
| 3.90-4.70 mm [.154-.185 IN] | | ∅2.54-3.81 mm [.100-.150 IN] | |
| TERMINAL APPLICATION SPECIFICATION | 114-3118 | | |
| TERMINALS APPLIED | | | |
| TE TERMINAL | TE TERMINAL | TE TERMINAL | TE TERMINAL |
| 163302-5 | 163302-7 | 163302-9 | 163303-6 |
| 163302-6 | 163302-8 | | 163303-8 |

| WIRE SIZE | CRIMP HEIGHT mm [INCH] | CRIMP HEIGHT REFERENCE SETTING |
|-----------|-------------------------------|--------------------------------|
| 2.50mm2 | 1.60 +/- 0.05 [.063 +/- .002] | 5.9 |
| 1.50mm2 | 1.60 +/- 0.05 [.063 +/- .002] | 6 |
| 1.00mm2 | 1.45 +/- 0.05 [.057 +/- .002] | 7.6 |

- RECOMMENDED SPARE PARTS
- REFER TO SUPPLIED INSTRUCTION SHEET FOR CLEANING, LUBRICATION AND STORAGE OF APPLICATOR.
- APPLY PART NUMBER 2-23419-6 LOCTITE TO THREADS OF ITEM 242.
- CRIMP HEIGHT REFERENCE SETTING WAS THE SETTING USED WHEN THE APPLICATOR WAS QUALIFIED AT THE FACTORY. ADJUSTMENT MAY BE NECESSARY WHEN RUNNING APPLICATOR IN THE FIELD.
- 5. UNLESS SPECIFIED OTHERWISE TORQUE VALUES SHALL BE USED PER DOCUMENT, 101-35000.

***WARNING**
 ON INSTALLATION, SET WIRE DISC TO CRIMP HEIGHT REFERENCE SETTING FOR LARGEST WIRE SIZE. CRIMP HEIGHT REFERENCE SETTINGS GREATER THAN THE VALUE SHOWN MAY CAUSE DAMAGE TO THE CRIMP TOOLING, REFER TO THE INSTRUCTION SHEET FOR PROPER SETUP AND ADJUSTMENTS.

| LOC | DIST | REVISIONS | | | | | |
|-----|------|-----------|-----|-------------|------|-----|------|
| | | P | LTN | DESCRIPTION | DATE | OWN | APVD |
| A | 66 | - | - | SEE SHEET 1 | - | - | - |

| | | | | | |
|---|-----|-----|-------------|-------------------------------------|-----|
| - | 1 | - | 2119640-1 | PUSH ROD, AIR FEED | 250 |
| - | 1 | - | 1803259-1 | BUSHING, FLANGED | 249 |
| - | 1 | 1 | 2119082-9 | CAM, SNAIL, INSULATION ADJUSTMENT | 244 |
| - | 1 | 1 | 2079764-1 | WASHER, WAVE SPRING, CREST-TO-CREST | 243 |
| - | 1 | 1 | 2119083-1 | RETAINER, INSULATION DIAL | 242 |
| - | 1 | 1 | 7-18023-7 | SCR, SKT HD CAP M3 X 4.0 | 241 |
| - | - | 1 | 2119580-1 | MECHANICAL FEED ASSEMBLY | 239 |
| - | 1 | - | 2063440-1 | AIR FEED MODULE | 238 |
| - | 2 | - | 21045-3 | RING, RETAIN, EXTERN, 3/16 CRESCENT | 172 |
| - | REF | REF | 994970-2 | COUNTER, MAGNETIC | 164 |
| - | 1 | - | 240638-1 | SPRING, FEED FINGER | 163 |
| - | 1 | - | 2119641-2 | FEED CAM, AIR FEED | 151 |
| - | 1 | 1 | 2168083-8 | SCR, SKT HD CAP, RoHS, M4 X 16 | 144 |
| - | 4 | 4 | 2168083-9 | SCR, SKT HD CAP, RoHS, M4 X 20 | 143 |
| - | - | 1 | 2119653-2 | FEED CAM, POST FEED | 142 |
| - | 1 | 1 | 1-1803583-0 | APPLICATOR BASIC ASSEMBLY, SF | 141 |
| - | 1 | 1 | 1803516-1 | RAM ASSEMBLY, SF PACIFIC | 140 |
| - | 1 | - | 3-23627-7 | PIN, RETAIN, GRVD, 3/16 X .854 | 137 |
| - | 1 | - | 2119799-1 | HOLDER, FEED FINGER, AF | 136 |
| - | 1 | 1 | 2844908-1 | SCREW, LOCKING | 99 |
| - | 1 | 1 | 2844907-1 | POST, LOCKING | 98 |
| - | 1 | 1 | 455888-5 | SPACER, CRIMPER | 82 |
| - | 1 | 1 | 1803607-1 | DOCUMENTATION PACKAGE | 71 |
| - | 1 | 1 | 2119791-5 | DEPRESSOR, WIRE | 70 |
| - | 1 | 1 | 2119943-1 | WASHER, SPACER | 69 |
| - | 1 | 1 | 2119740-1 | TAG, IDENTIFICATION | 67 |
| - | 2 | 2 | 2168078-1 | SCREW, DRIVE, RH, RoHS, 2 x .188 | 66 |
| - | 1 | 1 | 5-18022-5 | SCR, HEX HD CAP, M4 X 6.0 | 59 |
| - | 1 | 1 | 1338685-1 | PAWL, FEED | 56 |
| - | 2 | 2 | 1-2168083-0 | SCR, SKT HD CAP, RoHS, M4 X 10 | 53 |
| - | 1 | 1 | 5018030-1 | NUT, HEX, REG, RoHS, M3 | 52 |
| - | 1 | 1 | 811242-5 | BUMPER, HOLD DOWN | 51 |
| - | 1 | 1 | 690753-2 | SPACER, TONKER | 50 |
| - | 1 | 2 | 18023-9 | SCR, SKT HD CAP M4 X 6.0 | 49 |
| - | - | 1 | 2119652-1 | FEED CAM, PRE FEED | 48 |
| - | 1 | 1 | 1803602-1 | SCR, BHSC, RoHS (M8 X 25) | 41 |
| - | 1 | 1 | 1752356-1 | SUPPORT, TERMINAL | 34 |
| - | 2 | 2 | 2079383-5 | SCR, BHSC, RoHS (M4 X 20) | 33 |
| - | 2 | 2 | 3-2844962-0 | SPACER, CYLINDRICAL, STRIP GUIDE | 30 |
| - | 1 | 1 | 2844992-1 | ASSEMBLY, STRIP GUIDE | 29 |
| - | 1 | 1 | 455888-3 | SPACER, CRIMPER | 28 |
| - | 1 | 1 | 1320928-2 | STRIP GUIDE | 24 |
| - | 1 | 1 | 2168083-2 | SCR, SKT HD CAP, RoHS, M4 X 8.0 | 21 |
| - | 2 | 2 | 1-18028-2 | WASHER, FLAT, REG M4 | 20 |
| - | 1 | 1 | 2119533-1 | STRIPPER, SIDE FEED | 19 |
| - | 1 | 1 | 2119806-1 | INSERT, SHEAR | 13 |
| - | 1 | 1 | 3-22280-3 | SPRING, COMPRESSION | 12 |
| - | 1 | 1 | 1-356885-4 | STOP, SHEAR | 11 |
| - | 1 | 1 | 2119805-1 | SHEAR HOLDER, FRONT | 10 |
| - | 1 | 1 | 1803095-1 | FLOATING SHEAR, FRONT | 9 |
| - | 1 | 1 | 3-1333225-4 | ANVIL, COMBINATION | 8 |
| - | - | - | - | - | 7 |
| - | - | - | - | - | 6 |
| - | 1 | 1 | 1-2119757-0 | DEPRESSOR, SHEAR | 5 |
| - | 1 | 1 | 238011-7 | BLOCK, CRIMPER SPACER | 4 |
| - | 1 | 1 | 2119582-1 | CRIMPER, INSULATION F PREMIUM | 3 |
| - | 1 | 1 | 455888-2 | SPACER, CRIMPER | 2 |
| - | 1 | 1 | 5-456406-9 | CRIMPER, WIRE PREMIUM | 1 |

PACIFIC VERSION
 Shown on sheets 3 of 4 & 4 of 4
 (Atlantic version shown on sheets 1 of 4 & 2 of 4)

| | | | | | | | |
|----------------|---|--|---|--|---------|---------------|---|
| DIMENSIONS: mm | | TOLERANCES UNLESS OTHERWISE SPECIFIED: | | DRAWING NO | | RESTRICTED TO | |
| 0 PLC | ± | 1 PLC | ± | 00779 | 2151997 | 3 | 4 |
| 2 PLC | ± | 3 PLC | ± | Customer Accessible Production Drawing | | | |
| 4 PLC | ± | FINISH | | SCALE 1:2 SHEET 3 OF 4 REV C | | | |

| LOC | DIST | REVISIONS | | | | | |
|-----|------|-----------|-----|-------------|------|-----|------|
| A | 66 | P | LTN | DESCRIPTION | DATE | OWN | APVD |
| | | - | | SEE SHEET 1 | | | |

FEED TYPE MECHANICAL

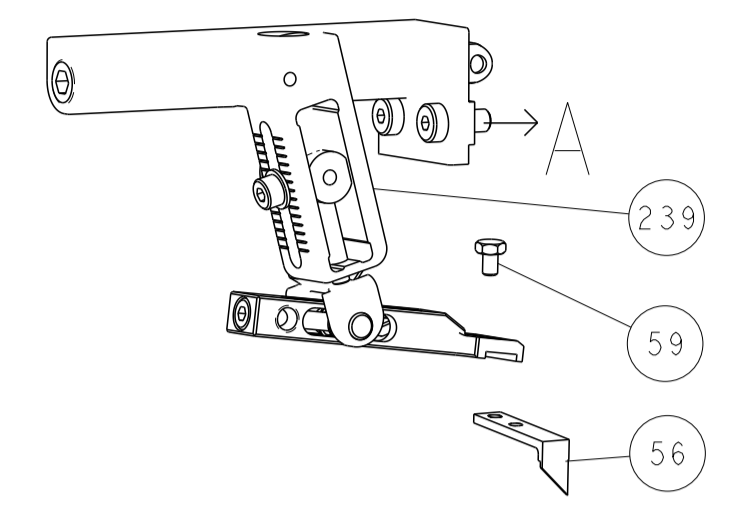

PNEUMATIC

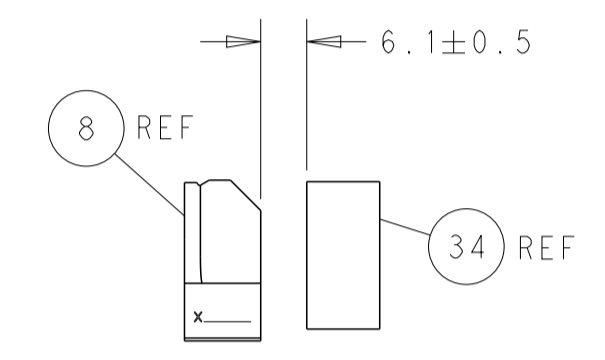
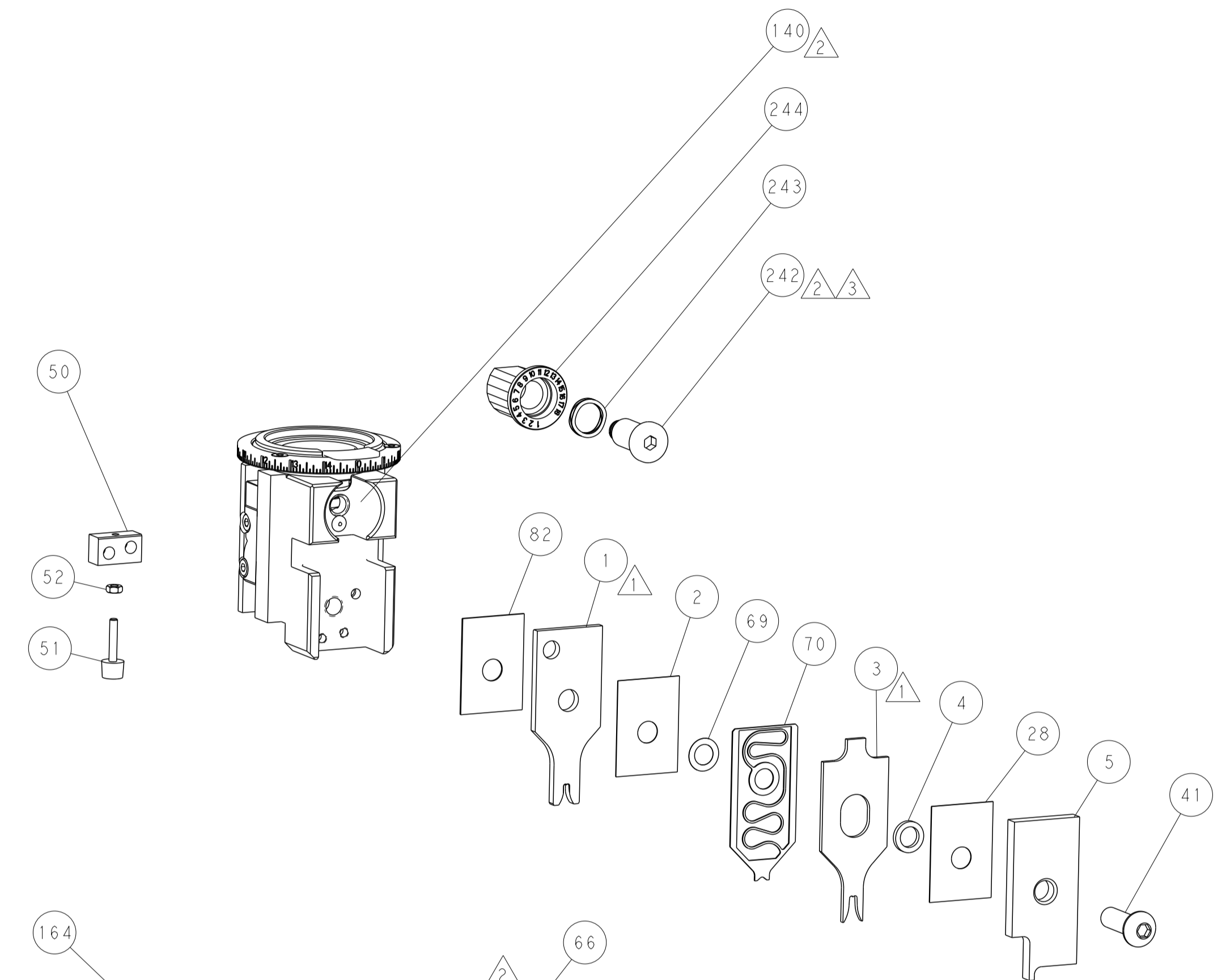
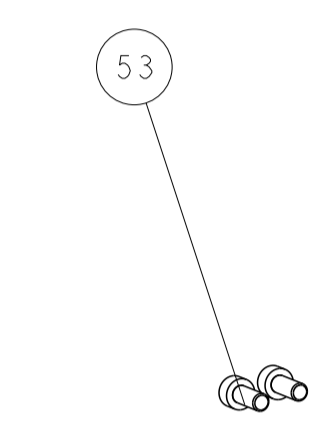
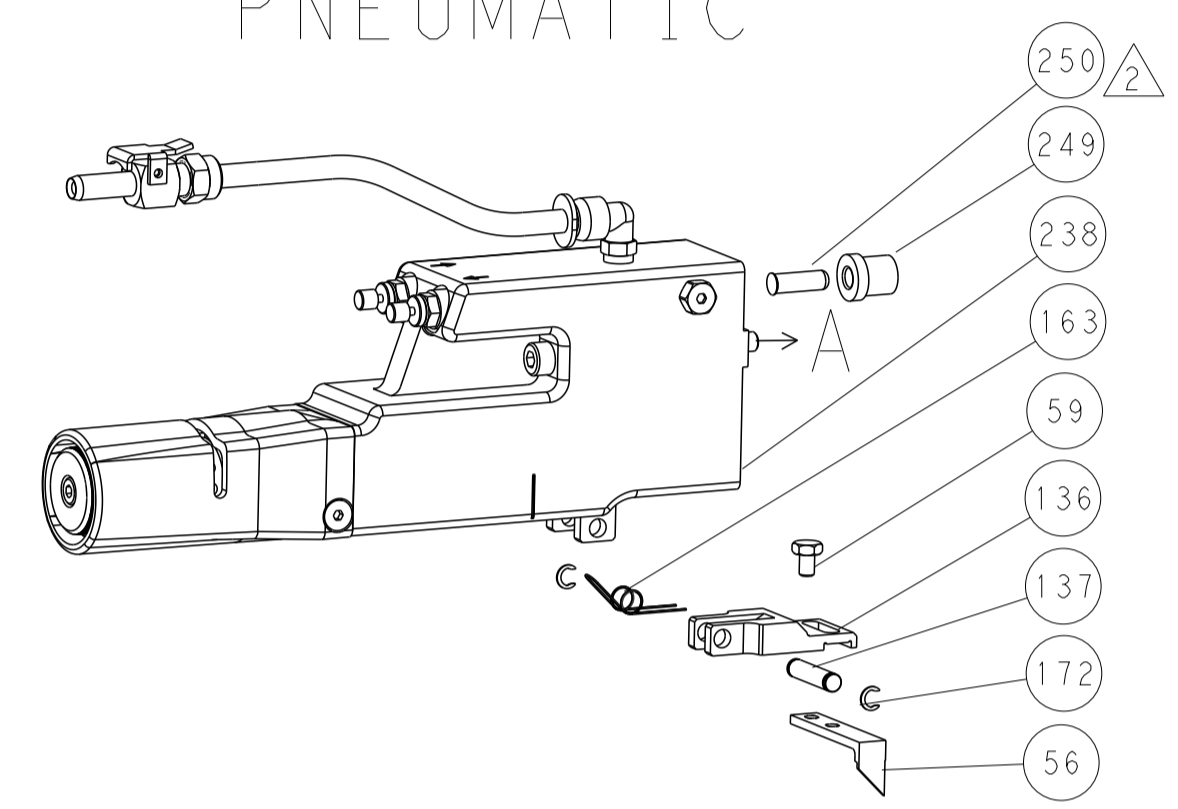

TERMINAL SUPPORT LOCATION

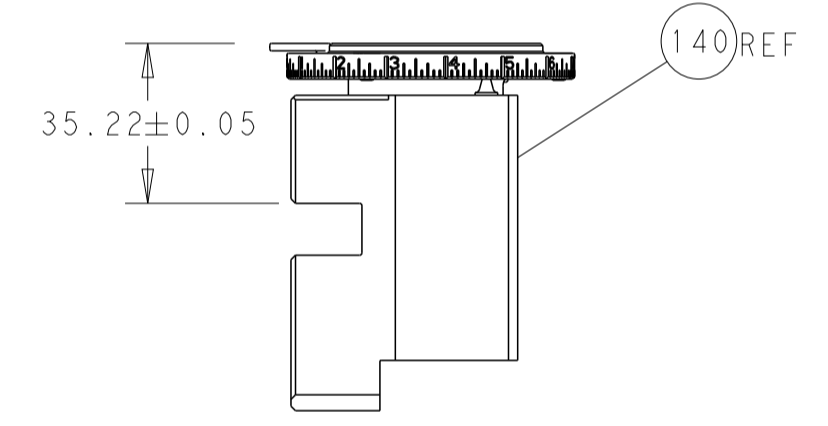
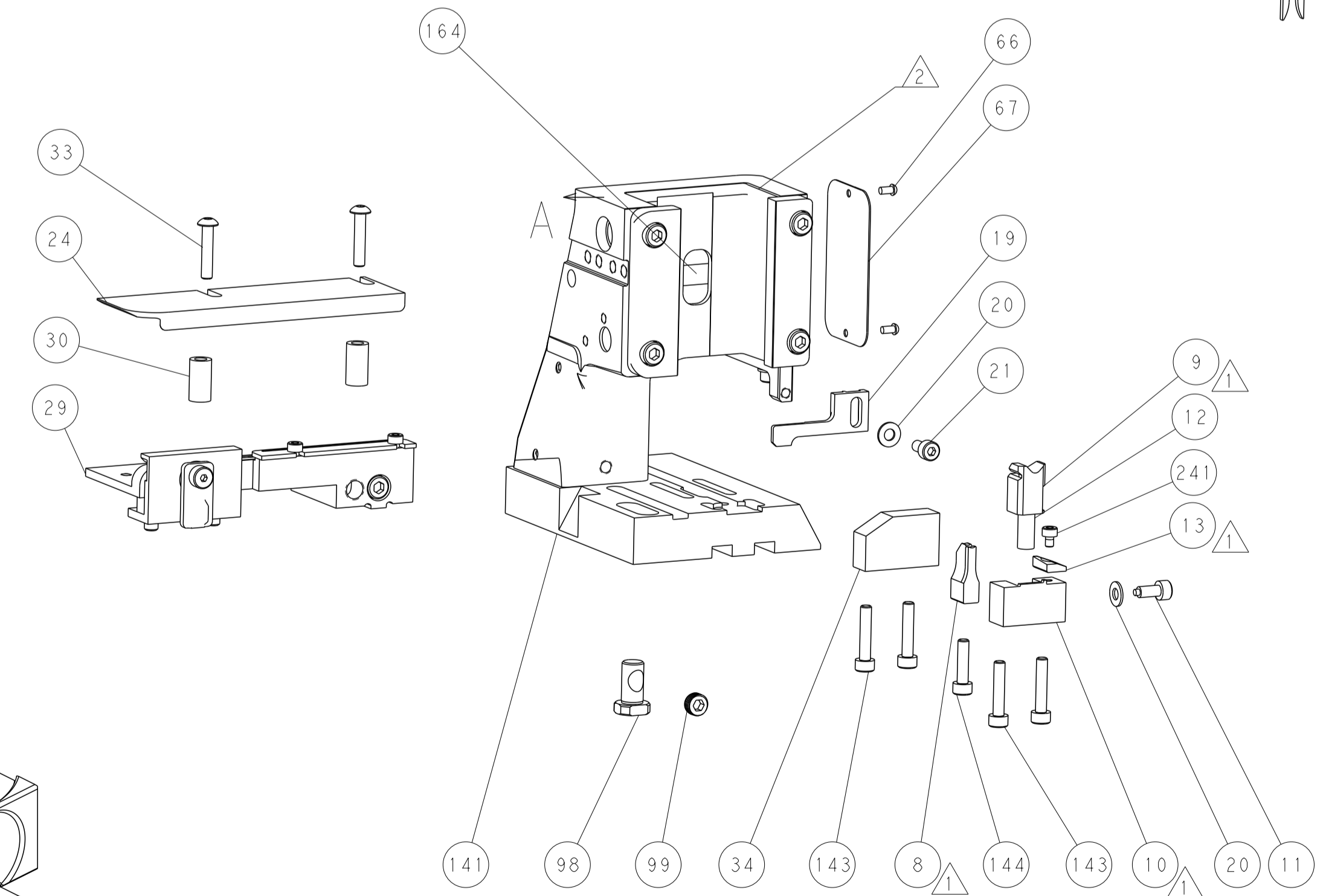

RAM SET-UP

CAM POSITIONS

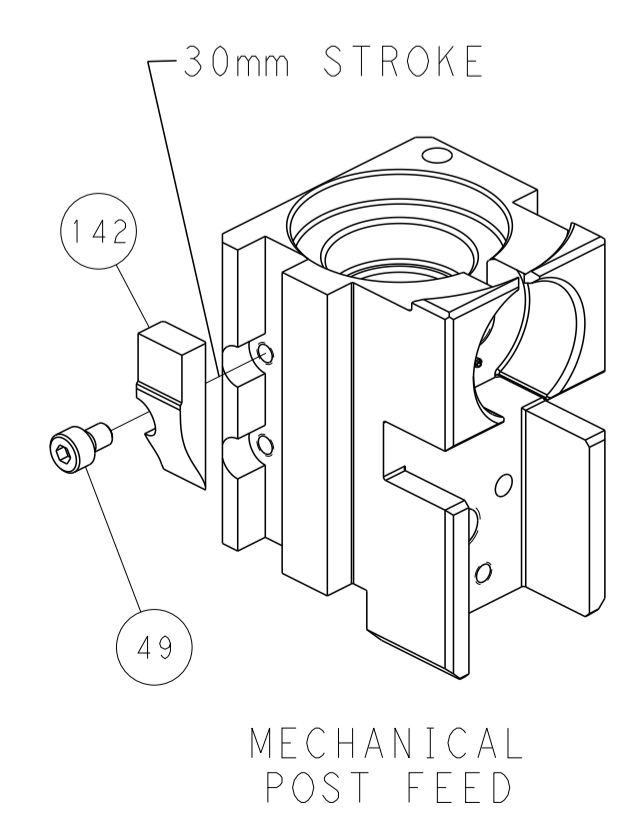

MECHANICAL POST FEED

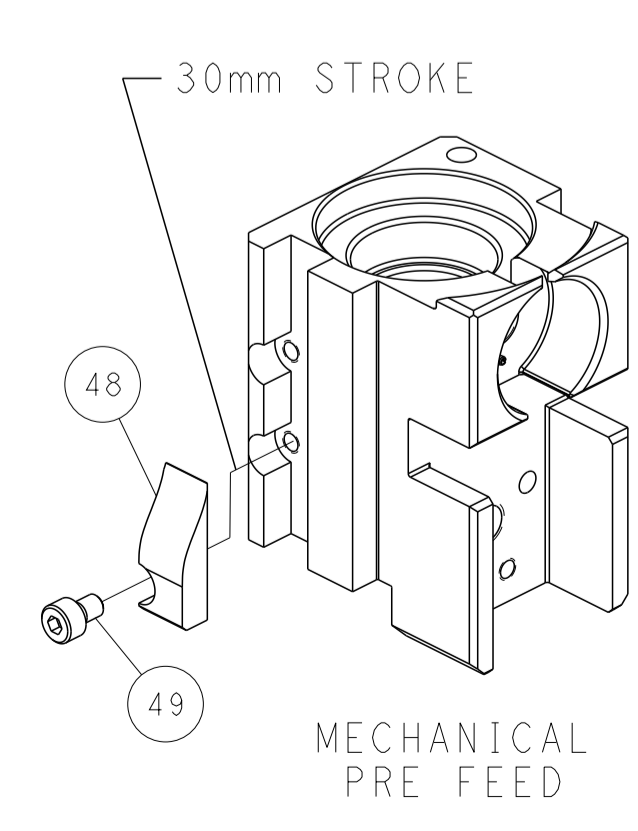

MECHANICAL PRE FEED

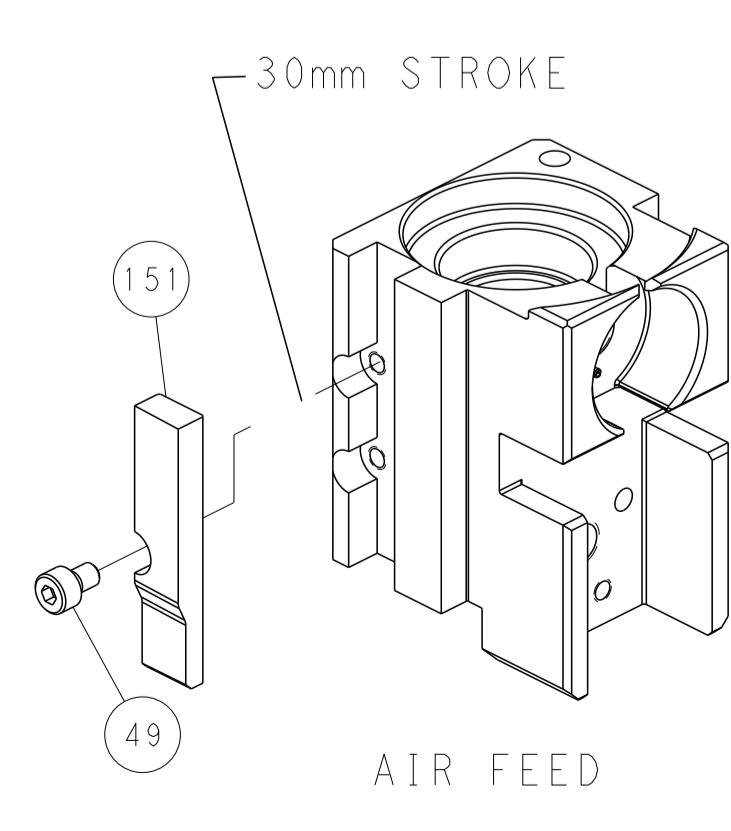

AIR FEED

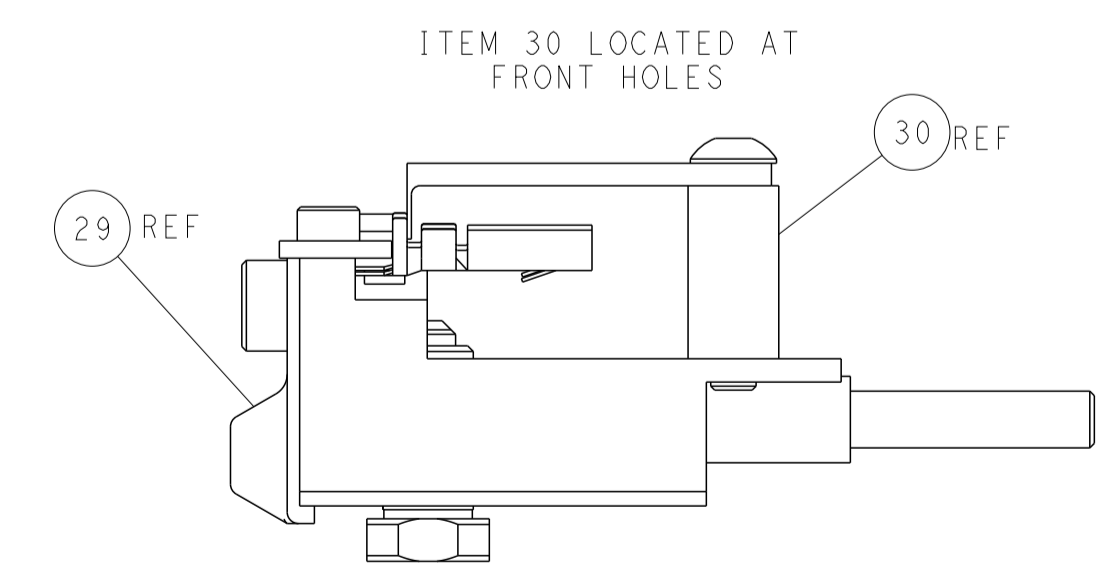

FEED TRACK POSITION GUIDE BY INSULATION BARREL

PACIFIC VERSION
 Shown on sheets 3 of 4 & 4 of 4
 (Atlantic version shown on sheets 1 of 4 & 2 of 4)

| | | | |
|---|---|--|--|
| <small>THIS DRAWING IS UNPUBLISHED. RELEASED FOR PUBLICATION. IT IS THE PROPERTY OF TYCO ELECTRONICS CORPORATION. IT IS TO BE USED ONLY FOR THE PURPOSES SPECIFIED AND IS NOT TO BE REPRODUCED OR TRANSMITTED IN ANY FORM OR BY ANY MEANS, ELECTRONIC OR MECHANICAL, INCLUDING PHOTOCOPYING, RECORDING, OR BY ANY INFORMATION STORAGE AND RETRIEVAL SYSTEM, WITHOUT THE WRITTEN PERMISSION OF TYCO ELECTRONICS CORPORATION.</small> | | DWN: HOFFNER 24JULY2013 CHK: TELBIN 25JULY2013 APVD: TELBIN 25JULY2013 | TE Connectivity Harrisburg, PA 17105-3608 |
| DIMENSIONS: mm TOLERANCES UNLESS OTHERWISE SPECIFIED: 0 PLC ±. 1 PLC ±. 2 PLC ±. 3 PLC ±. 4 PLC ±. ANGLES ±. FINISH: | NAME: Ocean Side Feed Applicator APPLICATION SPEC: | SIZE: A1 CAGE CODE: 00779 DRAWING NO: 2151997 | RESTRICTED TO: |
| MATERIAL: | WEIGHT: | SCALE: 1:2 | SHEET 4 OF 4 REV C |