

PART NUMBER	REVISION	DESCRIPTION	FEED TYPE
2151480-1	G	FINE CRIMP HEIGHT ADJUST	MECHANICAL
2151480-2	G	FINE CRIMP HEIGHT ADJUST	PNEUMATIC
5-2151480-1	G	SEAL STRIPPER CRIMPER TERMINATING UNIT	MECHANICAL
5-2151480-2	G	SEAL STRIPPER CRIMPER TERMINATING UNIT	PNEUMATIC
7-2151480-1	G	MECHANICAL AND CRIMP TOOLING KIT	MECHANICAL
7-2151480-2	G	PNEUMATIC AND CRIMP TOOLING KIT	PNEUMATIC
7-2151480-7	G	CRIMP TOOLING KIT	-

ATLANTIC VERSION TERMINATOR INTERFACE ADAPTER

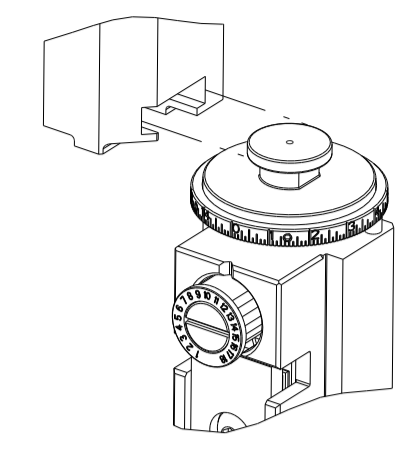

APPLICATOR DATA		
CRIMP	SIZE	TYPE
WIRE	1.78 mm [.070]	F
INSUL	3.30 mm [.130]	SP
APPLICATOR INSTRUCTIONS 408-35042		

TERMINAL DATA: TE TERMINAL		TE CRIMP SPECIFICATION	
TERMINAL NAME: TAB CONTACT 1.2MM			
WIRE STRIP LENGTH	INSULATION DIAMETER RANGE		
3.30-3.90 mm [.130-.154 IN]	∅ 2.6mm MAX		
TERMINAL APPLICATION SPECIFICATION	114-18464		

TERMINALS APPLIED				
TE TERMINAL	TE TERMINAL	TE SEAL	TE SEAL	CABLE DIAMETER
1718762-1	2177610-1		967067-1	∅ 1.4-2.1mm
1718762-2	2177610-3			
1718762-3	2208329-3			

WIRE SIZE	CRIMP HEIGHT mm [INCH]	CRIMP HEIGHT REFERENCE SETTING
1.50mm2	1.31+/-0.05 [.052+/- .002]	4.7
16 AWG	1.26+/-0.05 [.050+/- .002]	5.2
1.00mm2	1.10+/-0.05 [.043+/- .002]	7.0
18 AWG	1.05+/-0.05 [.041+/- .002]	7.5

- 1 RECOMMENDED SPARE PARTS
- 2 REFER TO SUPPLIED INSTRUCTION SHEET FOR CLEANING, LUBRICATION AND STORAGE OF APPLICATOR.
- 3 APPLY PART NUMBER 1-23419-5 LOCTITE TO THREADS OF ITEMS 180. APPLY PART NUMBER 2-23419-6 LOCTITE TO THREADS OF ITEM 242.
- 4 CRIMP HEIGHT REFERENCE SETTING WAS THE SETTING USED WHEN THE APPLICATOR WAS QUALIFIED AT THE FACTORY. ADJUSTMENT MAY BE NECESSARY WHEN RUNNING APPLICATOR IN THE FIELD.
- 5 APPLY TORO-SEAL IN ALLEN SOCKET TO FILL HOLE AFTER FLAT HD HAS BEEN ADJUSTED TO CORRECT HEIGHT AT QUALIFICATION. APPLY #1-23419-5 LOC-TITE TO THREADS.
- 6 TERMINAL LUBRICANT IS RECOMMENDED.
- 7. UNLESS SPECIFIED OTHERWISE TORQUE VALUES SHALL BE USED PER DOCUMENT, 101-35000.

***WARNING**
 ON INSTALLATION, SET WIRE DISC TO CRIMP HEIGHT REFERENCE SETTING FOR LARGEST WIRE SIZE. CRIMP HEIGHT REFERENCE SETTINGS GREATER THAN THE VALUE SHOWN MAY CAUSE DAMAGE TO THE CRIMP TOOLING, REFER TO THE INSTRUCTION SHEET FOR PROPER SETUP AND ADJUSTMENTS.

LOC	DIST	REVISIONS					
A	66	P	LTN	DESCRIPTION	DATE	OWN	APVD
		D1		ECR-18-005518	17APR2018	JYH	JDG
		E		ECR-18-010980	11JUL2018	JAH	CT
		F		ECR-19-005973	12APR2019	JAH	CT
		G		ECR-22-161197	14DEC2022	FZ	TE

-	-	-	1	1	-	-	1803515-3	RAM ASSEMBLY, SF ATLANTIC	293
-	-	-	1	1	-	-	2-1803583-1	APPLICATOR BASIC ASSEMBLY, SF	292
-	2	2	2	2	2	2	2168083-1	SCR, SKT HD CAP, RoHS, M3 X 8.0	269
-	1	1	1	1	1	1	1-1633782-2	FENCE	267
-	1	-	1	-	1	-	2119641-1	FEED CAM, AIR FEED	248
-	1	1	1	1	1	1	2119082-9	CAM, SNAIL, INSULATION ADJUSTMENT	244
-	1	1	1	1	1	1	2079764-1	WASHER, WAVE SPRING, CREST-TO-CREST	243
3	-	1	1	1	1	1	2119083-1	RETAINER, INSULATION DIAL	242
-	1	1	1	1	1	1	7-18023-7	SCR, SKT HD CAP M3 X 4.0	241
-	-	1	-	1	-	1	2119580-1	MECHANICAL FEED ASSEMBLY	239
-	1	-	1	-	1	-	2844940-1	AIR FEED MODULE	238
-	-	-	1	1	-	-	4-1722335-3	STRIPPER, SIDE FEED	182
3	-	-	-	1	1	-	1-5018030-0	NUT, HEX, REG, RoHS, M3.5	181
-	-	-	-	1	1	-	1-1752354-7	STANDOFF, HOLD-DOWN	180
-	-	-	-	1	1	-	993111-1	PIN, SLOTTED SPRING 3.0 X 20.0	177
-	-	-	-	1	1	-	5-22280-0	SPRING, COMPRESSION	176
-	-	-	-	1	1	-	1752353-3	GUIDE PIN, HOLDDOWN	175
-	-	-	-	1	1	-	1901680-2	GUIDE PIN, HOLDDOWN	174
-	REF	REF	REF	REF	REF	REF	994970-2	COUNTER, MAGNETIC	164
6	-	1	1	1	1	1	2119955-1	ASSY, LUBRICATOR, SIDE FEED	113
-	1	1	1	1	1	1	2844908-1	SCREW, LOCKING	99
-	1	1	1	1	1	1	2844907-1	POST, LOCKING	98
-	1	1	1	1	1	1	455888-4	SPACER, CRIMPER	82
-	1	1	1	1	1	1	1803607-3	DOCUMENTATION PACKAGE	71
-	1	1	1	1	1	1	2119740-1	TAG, IDENTIFICATION	67
-	2	2	2	2	2	2	2168078-1	SCREW, DRIVE, RH, RoHS, 2 x .188	66
-	1	1	1	1	1	1	2168083-2	SCR, SKT HD CAP, RoHS, M4 X 8.0	60
-	1	1	1	1	1	1	5-18022-5	SCR, HEX HD CAP, M4 X 6.0	59
5	-	1	1	1	1	1	985575-3	SCR, FLT SKT HD CAP M3 X 10.0	57
-	1	1	1	1	1	1	1338685-1	PAWL, FEED	56
-	4	4	4	4	4	4	2168083-3	SCR, SKT HD CAP, RoHS, M4 X 12.0	54
-	2	2	2	2	2	2	2168083-8	SCR, SKT HD CAP, RoHS, M4 X 16	53
-	1	1	1	1	1	1	5018030-1	NUT, HEX, REG, RoHS, M3	52
-	1	1	1	1	1	1	811242-5	BUMPER, HOLD DOWN	51
-	1	1	1	1	1	1	690753-2	SPACER, TONKER	50
-	1	2	1	2	1	2	18023-9	SCR, SKT HD CAP M4 X 6.0	49
-	-	1	-	1	-	1	2119652-1	FEED CAM, PRE FEED	48
-	-	1	-	1	-	1	2119653-1	FEED CAM, POST FEED	47
-	1	1	-	-	1	1	1803583-9	APPLICATOR BASIC ASSEMBLY, SF	46
-	1	1	-	-	1	1	1803515-1	RAM ASSEMBLY, SF ATLANTIC	44
-	1	1	1	1	1	1	1803602-1	SCR, BHSC, RoHS (M8 X 25)	41
-	1	1	1	1	1	1	1752356-6	SUPPORT, TERMINAL	34
-	2	2	2	2	2	2	2079383-5	SCR, BHSC, RoHS (M4 X 20)	33
-	2	2	2	2	2	2	3-2844962-0	SPACER, CYLINDRICAL, STRIP GUIDE	30
-	1	1	1	1	1	1	2844992-1	ASSEMBLY, STRIP GUIDE	29
-	1	1	1	1	1	1	455888-3	SPACER, CRIMPER	28
-	1	1	1	1	1	1	1320928-4	STRIP GUIDE	24
-	1	1	-	-	1	1	2168083-2	SCR, SKT HD CAP, RoHS, M4 X 8.0	21
-	2	2	1	1	2	2	1-18028-2	WASHER, FLAT, REG M4	20
-	1	1	-	-	1	1	2119533-1	STRIPPER, SIDE FEED	19
1	-	1	1	1	1	1	2119806-1	INSERT, SHEAR	13
-	1	1	1	1	1	1	3-22280-3	SPRING, COMPRESSION	12
-	1	1	1	1	1	1	1-356885-3	STOP, SHEAR	11
1	-	1	1	1	1	1	2119805-1	SHEAR HOLDER, FRONT	10
1	-	1	1	1	1	1	318707-1	FLOATING SHEAR, FRONT	9
1	2	2	1	1	1	1	4-1333203-8	ANVIL, COMBINATION	8
-	1	1	1	1	1	1	2-240641-0	SPACER	7
-	-	-	-	-	-	-	-	-	6
-	1	1	1	1	1	1	2119781-1	DEPRESSOR, SHEAR	5
-	1	1	1	1	1	1	238011-2	BLOCK, CRIMPER SPACER	4
1	2	2	1	1	1	1	1-1633996-8	CRIMPER, INSULATION SPECIAL	3
-	1	1	1	1	1	1	455888-3	SPACER, CRIMPER	2
1	2	2	1	1	1	1	3-456404-1	CRIMPER, WIRE PREMIUM	1

ATLANTIC VERSION
 Shown on sheets 1 of 4 & 2 of 4
 (Pacific version shown on sheets 3 of 4 & 4 of 4)

DIMENSIONS: mm 		TOLERANCES UNLESS OTHERWISE SPECIFIED: 0 PLC ± 1 PLC ± 2 PLC ± 3 PLC ± 4 PLC ± ANGLES FINISH ±		DWN H. HUANG 29AUG2012 CHK S. XI 29AUG2012 APVD S. XI 29AUG2012		TE Connectivity Harrisburg, PA 17105-3608	
MATERIAL:		WEIGHT:		SIZE: A1 CAGE CODE: 00779 DRAWING NO: C=2151480		RESTRICTED TO:	
Customer Accessible Production Drawing				SCALE: 1:2		SHEET 1 OF 4 REV G	

LOC	DIST	REVISIONS					
A	66	P	LTN	DESCRIPTION	DATE	DWN	APVD
		-		SEE SHEET 1			

FEED TYPE MECHANICAL

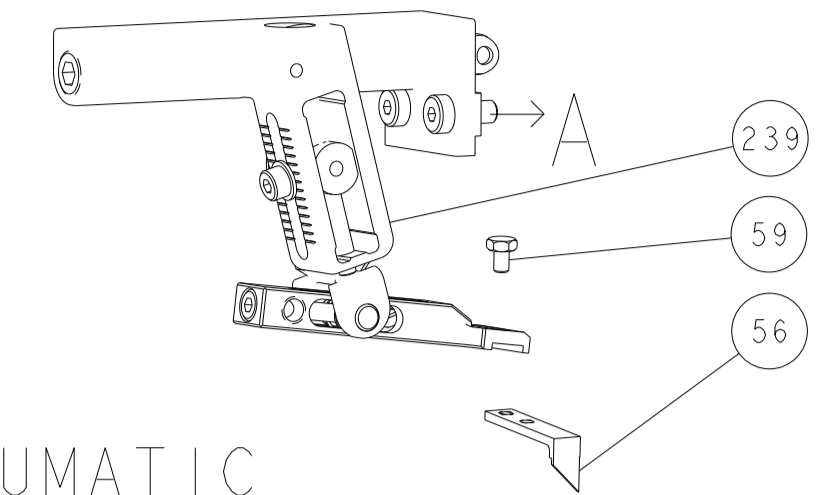

PNEUMATIC

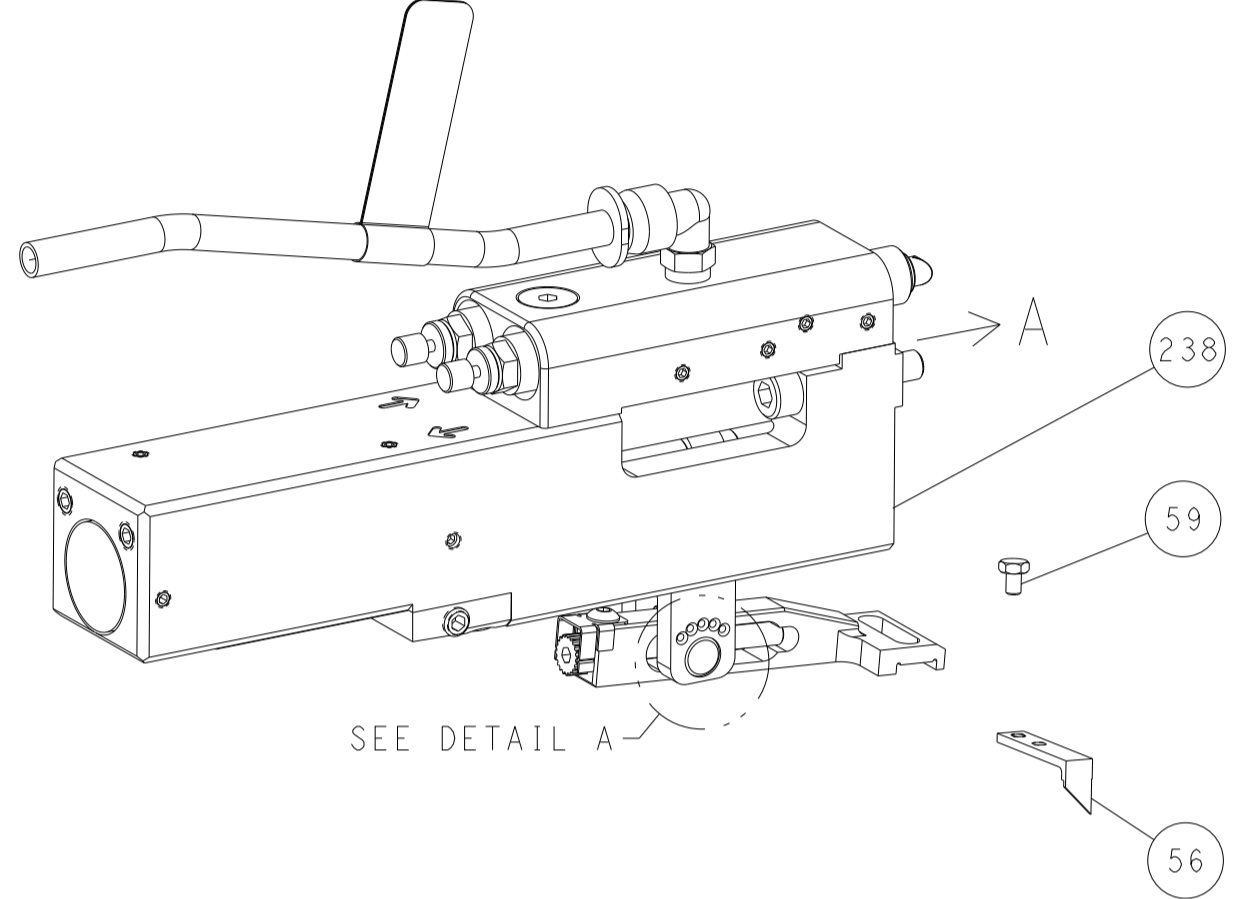

FEED SPRING SETTING POSITION (SHOWN FROM REAR SIDE)



DETAIL A

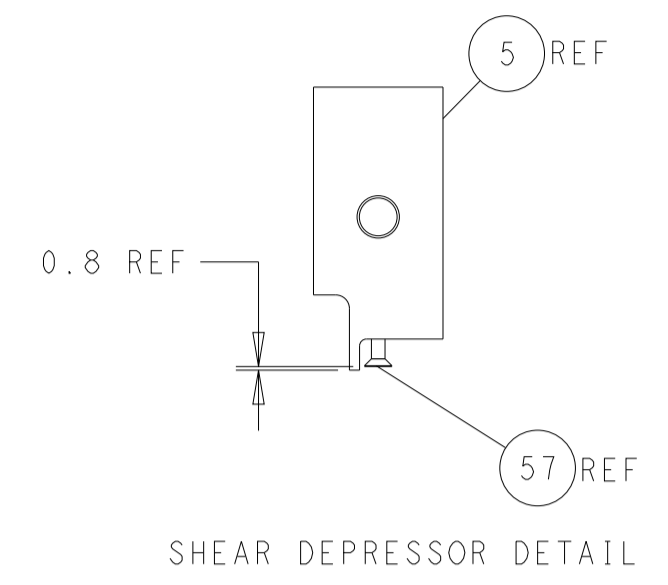
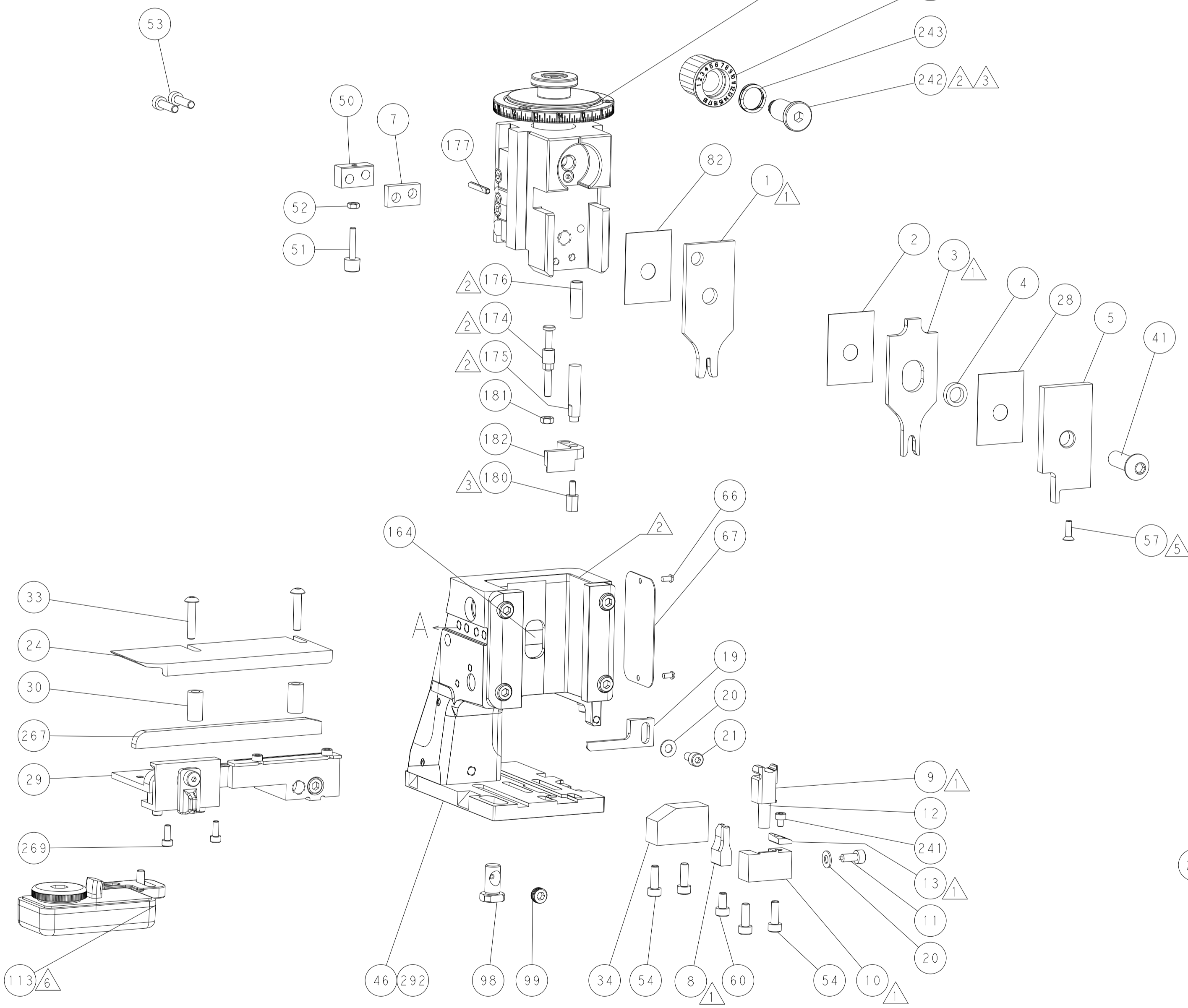

SHEAR DEPRESSOR DETAIL

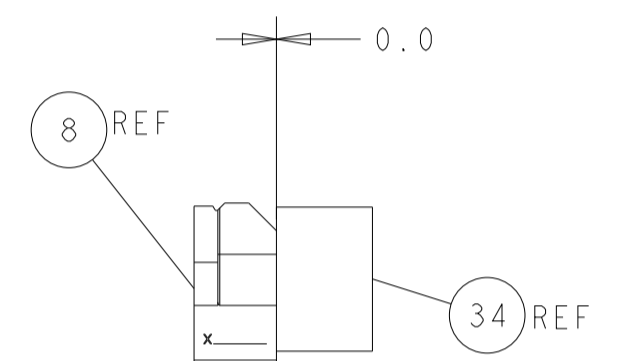

TERMINAL SUPPORT LOCATION

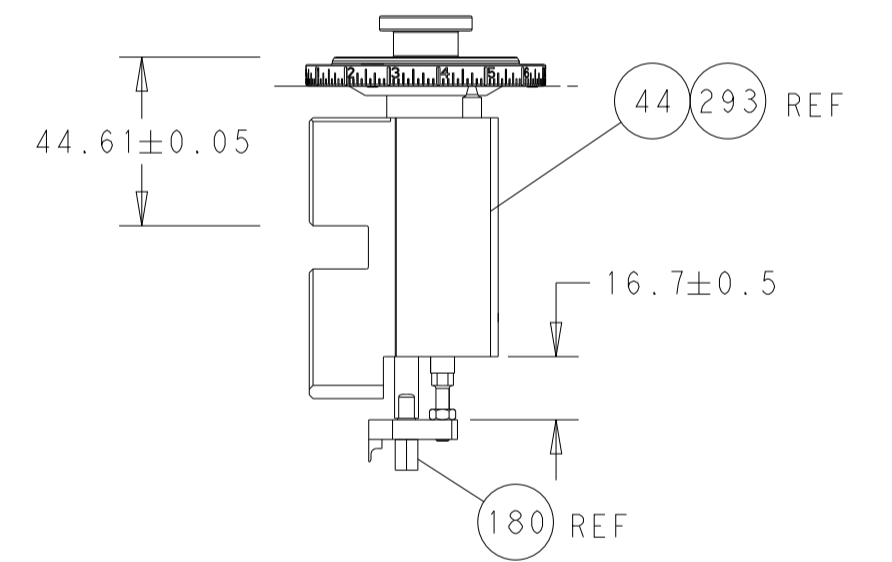

RAM AND HOLDDOWN SET UP

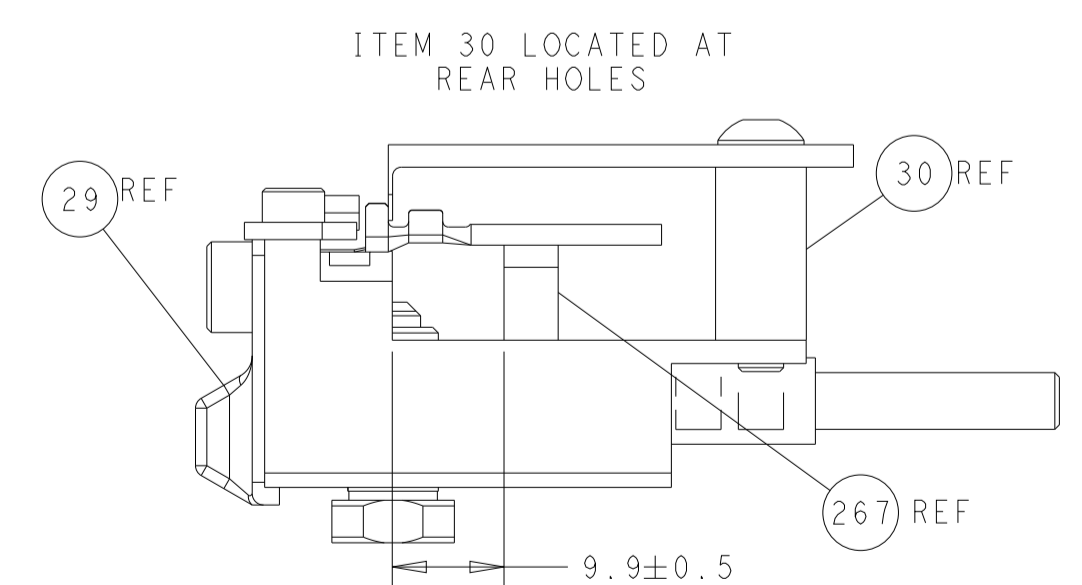

FEED TRACK POSITION GUIDE BY INSULATION BARREL

CAM POSITIONS

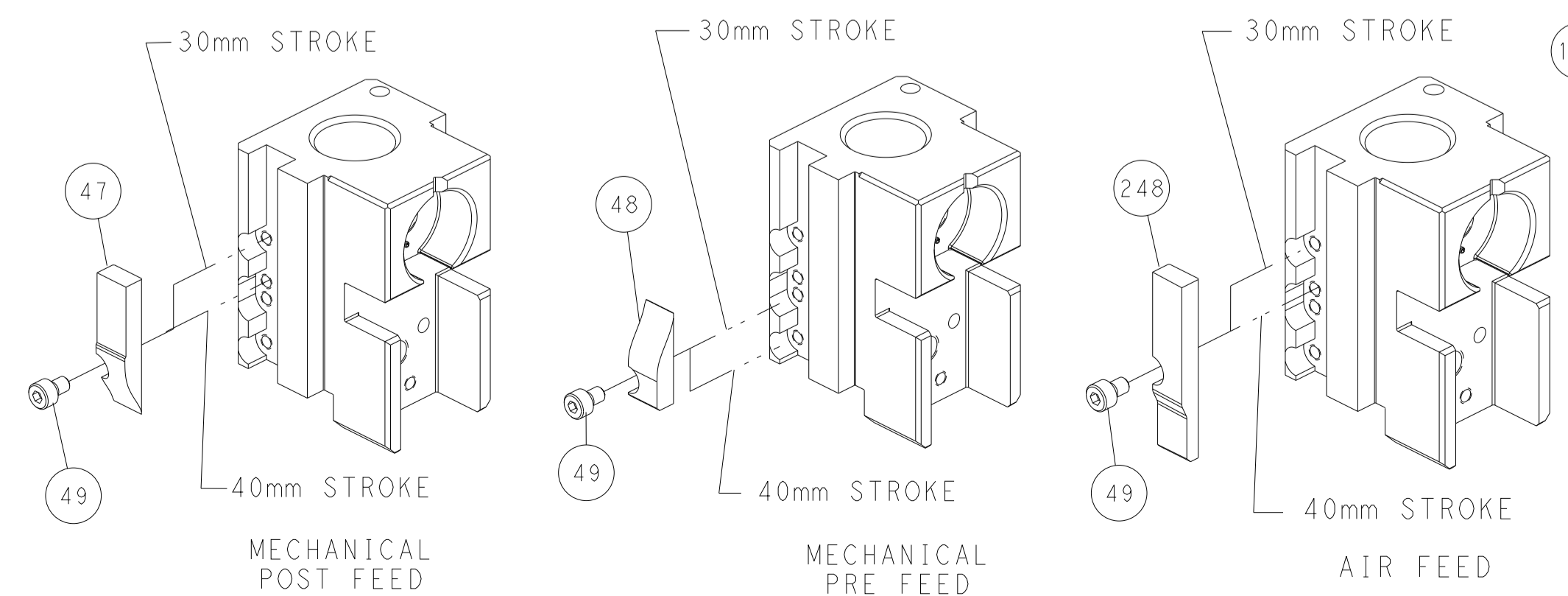

ATLANTIC VERSION
 Shown on sheets 1 of 4 & 2 of 4
 (Pacific version shown on sheets 3 of 4 & 4 of 4)

<small>THIS DRAWING IS UNPUBLISHED. RELEASED FOR PUBLICATION BY TYCO ELECTRONICS CORPORATION. ALL RIGHTS RESERVED.</small>		DWN: H. HUANG 29AUG2012 CHK: S. XI 29AUG2012 APVD: S. XI 29AUG2012	NAME: Ocean Side Feed Applicator SIZE: A1 CAGE CODE: 00779 DRAWING NO: 2151480	TE Connectivity Harrisburg, PA 17105-3608
DIMENSIONS: mm TOLERANCES UNLESS OTHERWISE SPECIFIED: 0 PLC ± 1 PLC ± 2 PLC ± 3 PLC ± 4 PLC ± ANGLES FINISH	TOLERANCES UNLESS OTHERWISE SPECIFIED: ± ± ± ± ±	WEIGHT: - SCALE: 1:2 SHEET: 2 OF 4 REV: G	RESTRICTED TO: -	Customer Accessible Production Drawing

PART NUMBER	REVISION	DESCRIPTION	FEED TYPE
2-2151480-1	G	FINE CRIMP HEIGHT ADJUST	MECHANICAL
2-2151480-2	G	FINE CRIMP HEIGHT ADJUST	PNEUMATIC
7-2151480-7	G	CRIMP TOOLING KIT	-

PACIFIC VERSION TERMINATOR
 INTERFACE ADAPTER



APPLICATOR DATA		
CRIMP	SIZE	TYPE
WIRE	1.78 mm [.070]	F
INSUL	3.30 mm [.130]	SP

APPLICATOR INSTRUCTIONS
 408-35042

TERMINAL DATA: TE TERMINAL		TE CRIMP SPECIFICATION	
TERMINAL NAME: TAB CONTACT 1.2MM			
WIRE STRIP LENGTH		INSULATION DIAMETER RANGE	
3.30-3.90 mm [1.130-1.54 IN]		∅ 2.6mm MAX	
TERMINAL APPLICATION SPECIFICATION	114-18464	-	-
TERMINALS APPLIED			
TE TERMINAL	TE TERMINAL	TE SEAL	TE SEAL
1718762-1	2177610-1		967067-1
1718762-2	2177610-3		
1718762-3	2208329-3		

WIRE SIZE	CRIMP HEIGHT mm [INCH]	CRIMP HEIGHT REFERENCE SETTING
1.50mm2	1.31+/-0.05 [0.052+/-0.002]	4.7
16 AWG	1.26+/-0.05 [0.050+/-0.002]	5.2
1.00mm2	1.10+/-0.05 [0.043+/-0.002]	7.0
18 AWG	1.05+/-0.05 [0.041+/-0.002]	7.5

***WARNING**
 ON INSTALLATION, SET WIRE DISC TO CRIMP HEIGHT REFERENCE SETTING FOR LARGEST WIRE SIZE. CRIMP HEIGHT REFERENCE SETTINGS GREATER THAN THE VALUE SHOWN MAY CAUSE DAMAGE TO THE CRIMP TOOLING, REFER TO THE INSTRUCTION SHEET FOR PROPER SETUP AND ADJUSTMENTS.

- RECOMMENDED SPARE PARTS
- REFER TO SUPPLIED INSTRUCTION SHEET FOR CLEANING, LUBRICATION AND STORAGE OF APPLICATOR.
- APPLY PART NUMBER 2-23419-6 LOCTITE TO THREADS OF ITEM 242.
- CRIMP HEIGHT REFERENCE SETTING WAS THE SETTING USED WHEN THE APPLICATOR WAS QUALIFIED AT THE FACTORY. ADJUSTMENT MAY BE NECESSARY WHEN RUNNING APPLICATOR IN THE FIELD.
- APPLY TORQ-SEAL IN ALLEN SOCKET TO FILL HOLE AFTER FLAT HD HAS BEEN ADJUSTED TO CORRECT HEIGHT AT QUALIFICATION. APPLY #1-23419-5 LOC-TITE TO THREADS.
- TERMINAL LUBRICANT IS RECOMMENDED.
- UNLESS SPECIFIED OTHERWISE TORQUE VALUES SHALL BE USED PER DOCUMENT, 101-35000.

LOC	DIST	REVISIONS					
A	66	P	LTN	DESCRIPTION	DATE	OWN	APVD
-	-	-	-	SEE SHEET 1	-	-	-

-	2	2	2168083-1	SCR, SKT HD CAP, RoHS, M3 X 8.0	269
-	1	1	1-1633782-2	FENCE	267
-	1	1	2119082-9	CAM, SNAIL, INSULATION ADJUSTMENT	244
-	1	1	2079764-1	WASHER, WAVE SPRING, CREST-TO-CREST	243
-	1	1	2119083-1	RETAINER, INSULATION DIAL	242
-	1	1	7-18023-7	SCR, SKT HD CAP M3 X 4.0	241
-	-	1	2119580-1	MECHANICAL FEED ASSEMBLY	239
-	1	-	2844940-1	AIR FEED MODULE	238
-	REF	REF	994970-2	COUNTER, MAGNETIC	164
-	1	-	2119641-2	FEED CAM, AIR FEED	151
-	1	1	2168083-8	SCR, SKT HD CAP, RoHS, M4 X 16	144
-	4	4	2168083-9	SCR, SKT HD CAP, RoHS, M4 X 20	143
-	-	1	2119653-2	FEED CAM, POST FEED	142
-	1	1	1-1803583-0	APPLICATOR BASIC ASSEMBLY, SF	141
-	1	1	1803516-1	RAM ASSEMBLY, SF PACIFIC	140
-	1	1	2119955-1	ASSY, LUBRICATOR, SIDE FEED	113
-	1	1	2844908-1	SCREW, LOCKING	99
-	1	1	2844907-1	POST, LOCKING	98
-	1	1	455888-4	SPACER, CRIMPER	82
-	1	1	1803607-3	DOCUMENTATION PACKAGE	71
-	1	1	2119740-1	TAG, IDENTIFICATION	67
-	2	2	2168078-1	SCREW, DRIVE, RH, RoHS, 2 x .188	66
-	1	1	5-18022-5	SCR, HEX HD CAP, M4 X 6.0	59
-	1	1	985575-3	SCR, FLT SKT HD CAP M3 X 10.0	57
-	1	1	1338685-1	PAWL, FEED	56
-	2	2	2168083-8	SCR, SKT HD CAP, RoHS, M4 X 16	53
-	1	1	5018030-1	NUT, HEX, REG, RoHS, M3	52
-	1	1	811242-5	BUMPER, HOLD DOWN	51
-	1	1	690753-2	SPACER, TONKER	50
-	1	2	18023-9	SCR, SKT HD CAP M4 X 6.0	49
-	-	1	2119652-1	FEED CAM, PRE FEED	48
-	1	1	1803602-1	SCR, BHSC, RoHS (M8 X 25)	41
-	1	1	1752356-6	SUPPORT, TERMINAL	34
-	2	2	2079383-5	SCR, BHSC, RoHS (M4 X 20)	33
-	2	2	3-2844962-0	SPACER, CYLINDRICAL, STRIP GUIDE	30
-	1	1	2844992-1	ASSEMBLY, STRIP GUIDE	29
-	1	1	455888-3	SPACER, CRIMPER	28
-	1	1	1320928-4	STRIP GUIDE	24
-	1	1	2168083-2	SCR, SKT HD CAP, RoHS, M4 X 8.0	21
-	2	2	1-18028-2	WASHER, FLAT, REG M4	20
-	1	1	2119533-1	STRIPPER, SIDE FEED	19
-	1	1	2119806-1	INSERT, SHEAR	13
-	1	1	3-22280-3	SPRING, COMPRESSION	12
-	1	1	1-356885-3	STOP, SHEAR	11
-	1	1	2119805-1	SHEAR HOLDER, FRONT	10
-	1	1	318707-1	FLOATING SHEAR, FRONT	9
-	1	1	4-1333203-8	ANVIL, COMBINATION	8
-	1	1	2-240641-0	SPACER	7
-	-	-	-	-	6
-	1	1	2119781-1	DEPRESSOR, SHEAR	5
-	1	1	238011-2	BLOCK, CRIMPER SPACER	4
-	1	1	1-1633996-8	CRIMPER, INSULATION SPECIAL	3
-	1	1	455888-3	SPACER, CRIMPER	2
-	1	1	3-456404-1	CRIMPER, WIRE PREMIUM	1

DIMENSIONS:		TOLERANCES UNLESS OTHERWISE SPECIFIED:		MATERIAL:	
mm	0 PLC ±	1 PLC ±	2 PLC ±	3 PLC ±	4 PLC ±
	ANGLES ±	FINISH			

ITEM NO	PART NO	DESCRIPTION
-77	-22	-21

OWN	H. HUANG	29AUG2012
CHK	S. XI	29AUG2012
APVD	S. XI	29AUG2012
PRODUCT SPEC		
APPLICATION SPEC		
SIZE	A1	00779
CAGE CODE		
DRAWING NO		
RESTRICTED TO		
SCALE	1:2	
SHEET	3	OF 4
REV	G	

PACIFIC VERSION
 Shown on sheets 3 of 4 & 4 of 4
 (Atlantic version shown on sheets 1 of 4 & 2 of 4)

LOC	DIST	REVISIONS					
A	66	P	LYN	DESCRIPTION	DATE	DWN	APVD
		-		SEE SHEET 1			

FEED TYPE MECHANICAL



PNEUMATIC

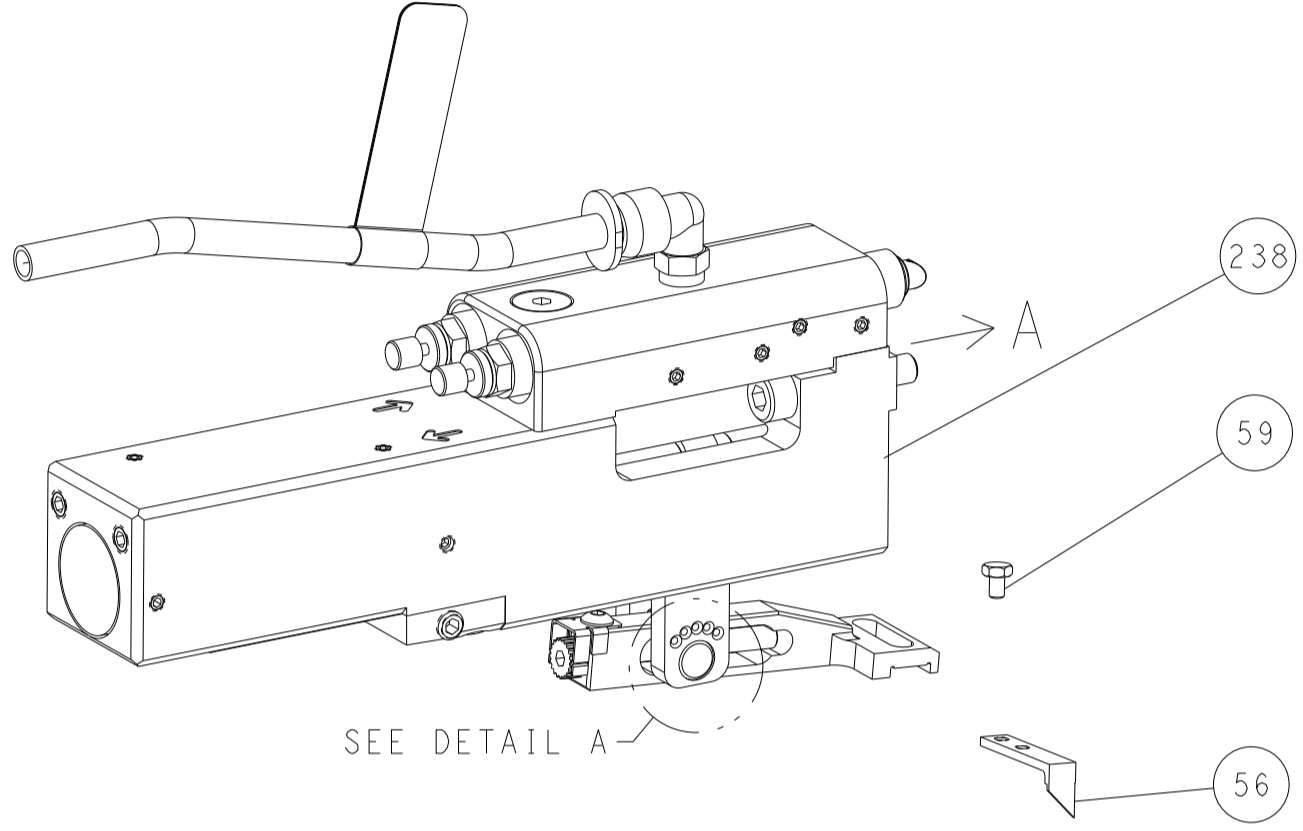

FEED SPRING SETTING POSITION (SHOWN FROM REAR SIDE)



CAM POSITIONS

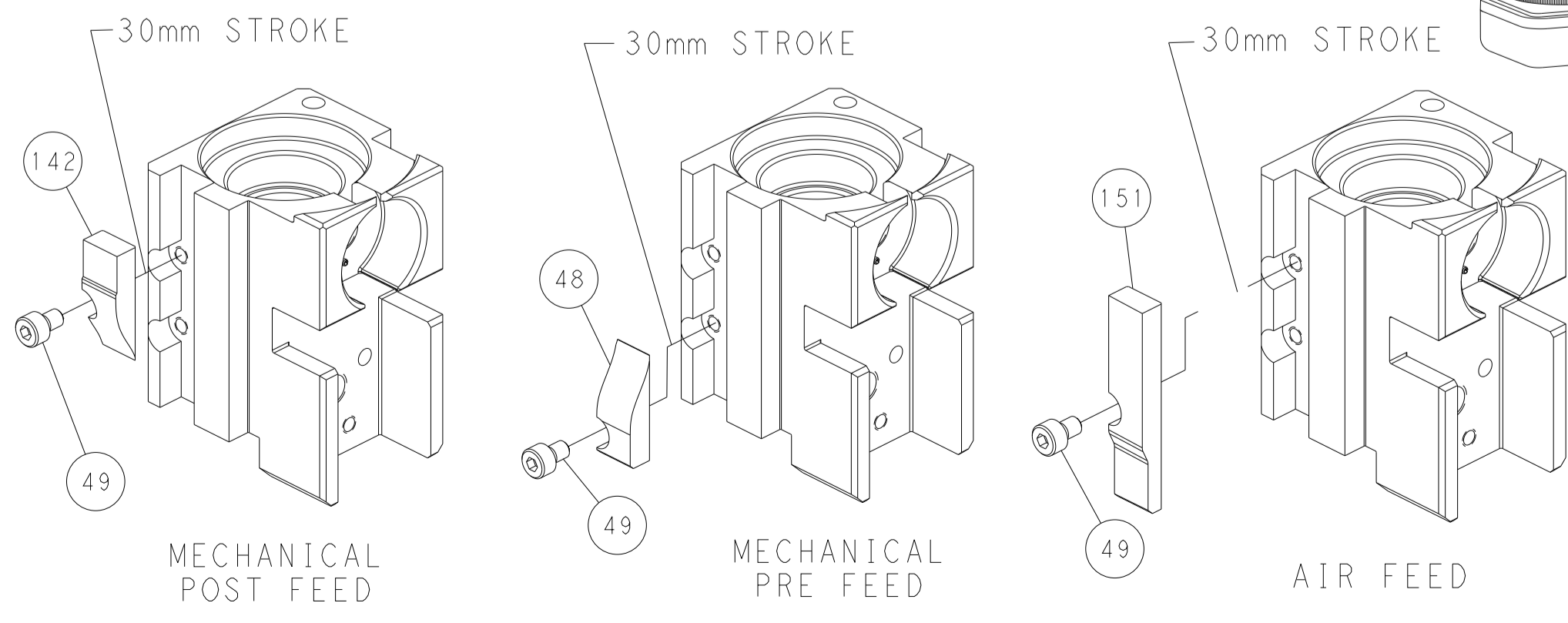

PACIFIC VERSION
 Shown on sheets 3 of 4 & 4 of 4
 (Atlantic version shown on sheets 1 of 4 & 2 of 4)

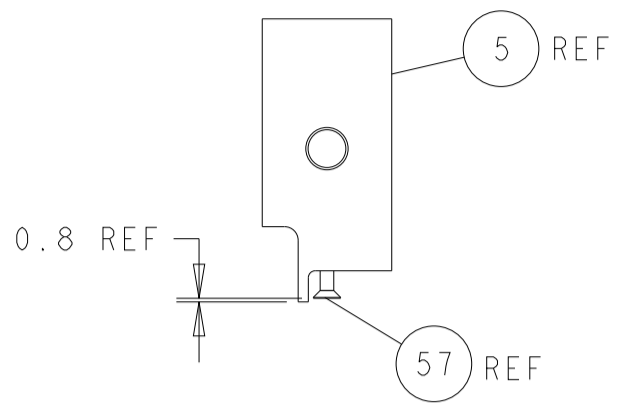
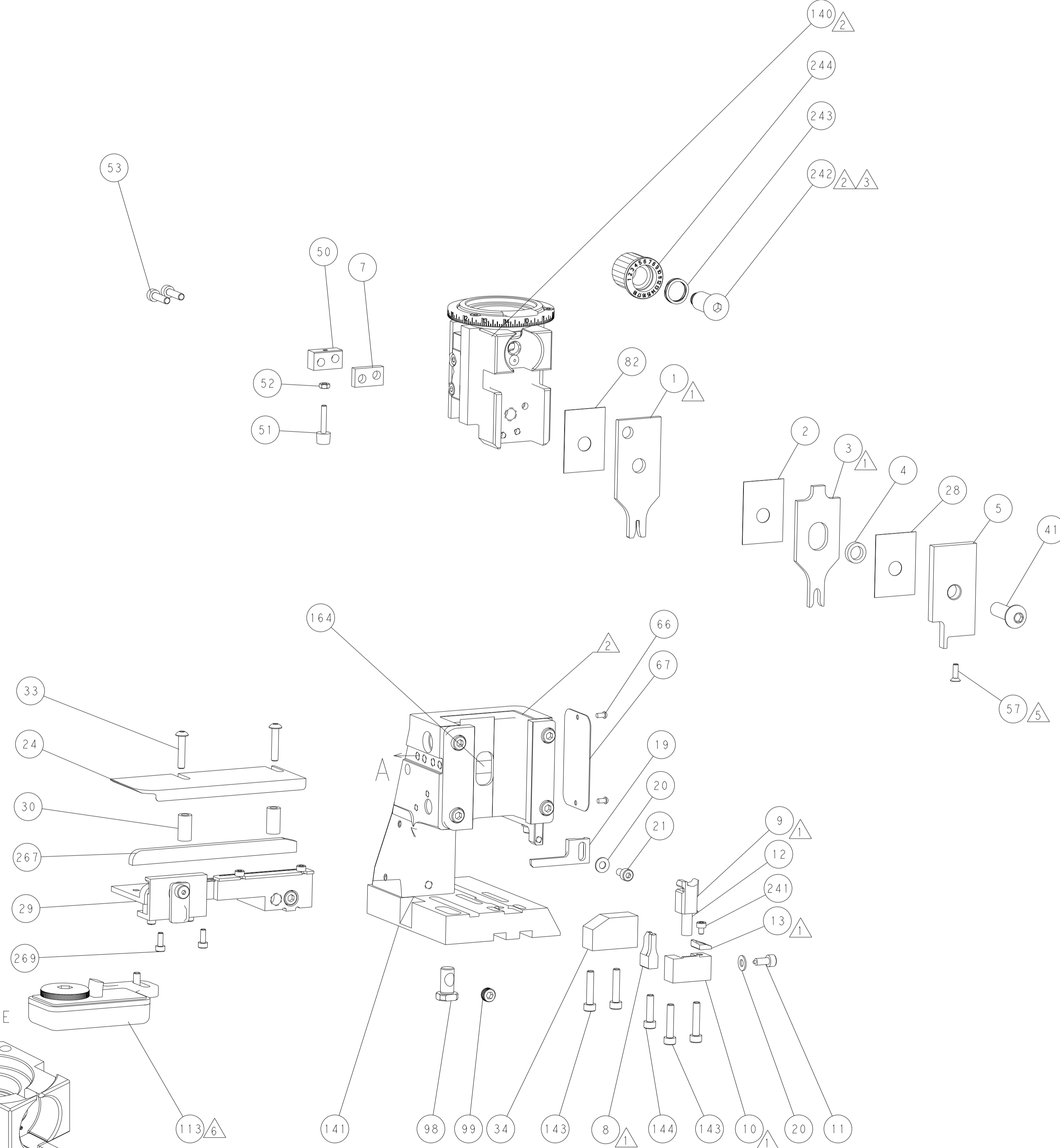

SHEAR DEPRESSOR DETAIL

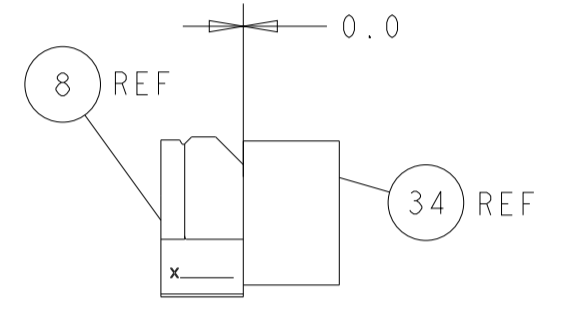

TERMINAL SUPPORT LOCATION

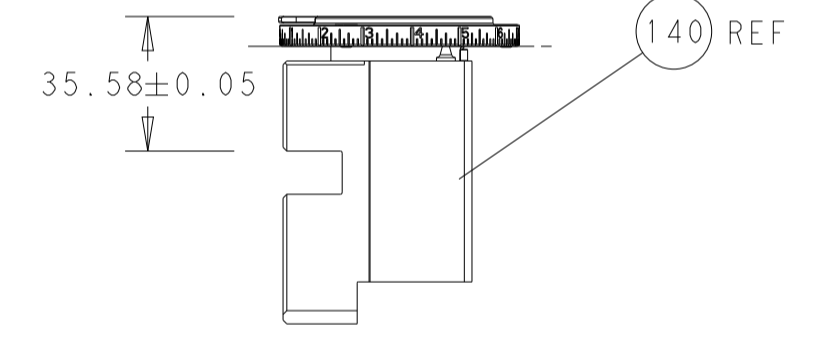

RAM SET-UP

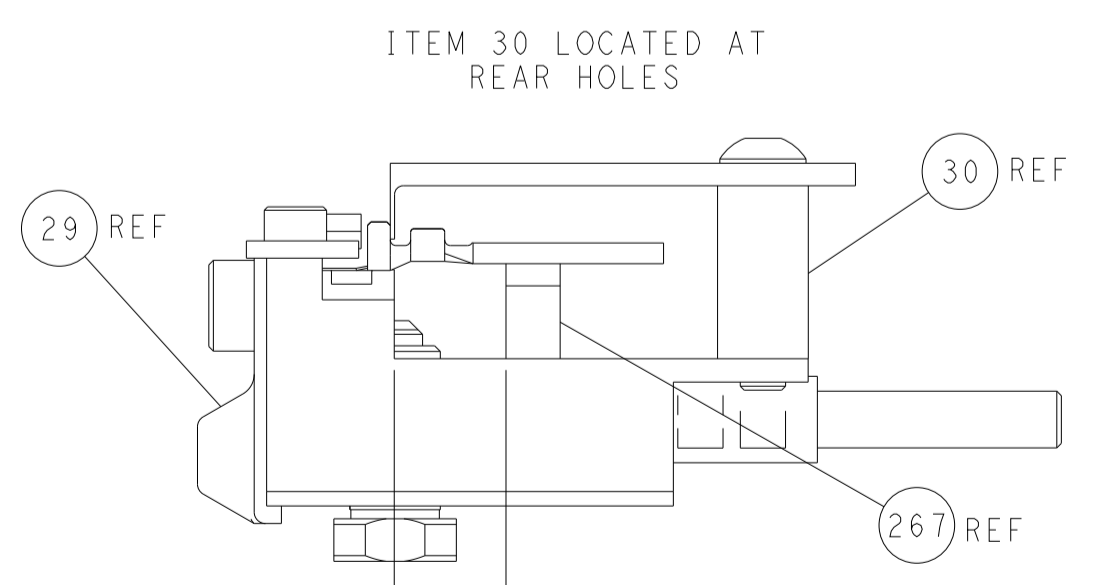

FEED TRACK POSITION GUIDE BY INSULATION BARREL

DIMENSIONS: mm 		TOLERANCES UNLESS OTHERWISE SPECIFIED: 0 PLC ± 1 PLC ± 2 PLC ± 3 PLC ± 4 PLC ± ANGLES ± FINISH		DWN H. HUANG 29AUG2012 CHK S. XI 29AUG2012 APVD S. XI 29AUG2012 PRODUCT SPEC APPLICATION SPEC WEIGHT Customer Accessible Production Drawing		NAME Ocean Side Feed Applicator SIZE CAGE CODE DRAWING NO A1 00779 C=2151480 SCALE 1:2 SHEET 4 OF 4 REV G	
MATERIAL:				TE Connectivity Harrisburg, PA 17105-3608		RESTRICTED TO	