

ATLANTIC VERSION TERMINATOR INTERFACE ADAPTER	PART NUMBER	REVISION	DESCRIPTION	FEED TYPE	APPLICATOR STYLE CONVERSION CHART						
					CONVERT TO	PART NUMBERS REQUIRED					
	2150585-2	A	FINE CRIMP HEIGHT ADJUST	PNEUMATIC	-	-	-	-	-	-	
	2150585-5	A	FINE CRIMP HEIGHT ADJUST	SERVO LATCH PLATE	SERVO LATCH PLATE	2119951-1	1901697-1	8-2150585-5	-	-	2168400-7 (QUANTITY 2)
					SMART APPLICATOR	2161326-1	-	8-2150585-4	-	-	-
	2150585-6	A	NON-CRIMP HEIGHT ADJUST	SERVO LATCH PLATE	PNEUMATIC FEED	2119950-1	2119792-2	-	2119641-1	-	2063440-2
					-	-	-	-	-	-	-
	2150585-7	A	FINE CRIMP HEIGHT ADJUST	NONE	-	-	-	-	-	-	-
	7-2150585-7	A	CRIMP TOOLING KIT	-	-	-	-	-	-	-	-

APPLICATOR DATA		
CRIMP	SIZE	TYPE
WIRE	5.33 mm [.210]	F
INSUL	6.35 mm [.250]	F
APPL INSTRUCTIONS 408-10390		

TERMINAL DATA: TE TERMINAL		TE CRIMP SPECIFICATION	
TERMINAL NAME: RING TONGUE			
WIRE STRIP LENGTH		INSULATION DIAMETER RANGE	
3.56-4.36 mm [.140-.172 IN]		Ø3.81-5.33 mm [.150-.210 IN]	
TERMINAL APPLICATION SPECIFICATION	114-2084	-	-
TERMINALS APPLIED			
TE TERMINAL	TE TERMINAL	TE TERMINAL	TE TERMINAL
140651	140653	140656	
140652	140655		

WIRE SIZE	CRIMP HEIGHT mm [INCH]	CRIMP HEIGHT REFERENCE SETTING
10 AWG	2.87+/-0.05 [.113+/-0.002]	6.1
12 AWG	2.59+/-0.05 [.102+/-0.002]	8.9

- RECOMMENDED SPARE PARTS
- GREASE BEARING SURFACES LIGHTLY
- 3. LUBRICATE DAILY PER THE APPLICATOR INSTRUCTION SHEET SUPPLIED WITH THE APPLICATOR.
- APPLICATOR SPECIFIC DATA TO BE ENTERED INTO BLANK MEMORY CHIP AT ASSEMBLY. SEE BELOW FOR PART NUMBER:
 PNEUMATIC FEED WITH "SMART APPLICATOR" CONVERSION: 8-2150585-4
 SERVO FEED WITH "FINE CRIMP HEIGHT ADJUST": 8-2150585-5
 SERVO FEED WITH "NON-CRIMP HEIGHT ADJUST": 8-2150585-6
- 5. ADJUSTMENT OF THE STRIPPER MAY BE REQUIRED WHEN MOVING THE APPLICATOR BETWEEN BENCH AND LEADMAKER APPLICATIONS.
- APPLY PART NUMBER 1-23419-5 LOCTITE TO THREADS OF ITEMS 62 & 180. APPLY PART NUMBER 2-23419-6 LOCTITE TO THREADS OF ITEM 242. FOR -6 ONLY APPLY PART NUMBER 1-23419-5 LOCTITE TO THREADS OF ITEMS 37 & 180.
- GREASE THREADS, GROOVE AND O-RING ON ITEMS 35 & 252.
- MAGNET, ITEM 166 MUST BE ORIENTED CORRECTLY IN ORDER TO PROPERLY ACTUATE THE COUNTER.
- CRIMP HEIGHT REFERENCE SETTING WAS THE SETTING USED WHEN THE APPLICATOR WAS QUALIFIED AT THE FACTORY. ADJUSTMENT MAY BE NECESSARY WHEN RUNNING APPLICATOR IN THE FIELD.
- TERMINAL PITCH NOT COMPATIBLE WITH MECHANICAL FEED.
- WHEN ASSEMBLING -6 NON-CRIMP HEIGHT ADJUST APPLICATOR USE SHIM PACK 2119957-2 TO ALIGN APPLICATOR'S MAXIMUM WIRE CRIMP HEIGHT AT NORMAL TERMINATOR SHUT HEIGHT

***WARNING**
 ON INSTALLATION, SET WIRE DISC, ITEM 40 TO LARGEST WIRE SIZE SETTING. USE OF SETTINGS BELOW MINIMUM REQUIRED CRIMP HEIGHT SETTING WILL CAUSE DAMAGE TO CRIMP TOOLING.

-	-	1	-	-	2119957-2	APPLICATOR SHIM PACK	260
-	1	-	1	1	8-21084-0	O-RING, .676 ID, .070 DIA. MAT.	252
-	-	-	-	1	2119640-1	PUSH ROD, AIR FEED	250
-	-	-	-	1	2079988-1	BUSHING, LCH5-12, MISUMI	249
-	-	-	-	1	2119641-1	FEED CAM, AIR FEED	248
-	1	-	1	1	2119798-1	DETENT PIN	247
-77	-7	-6	-5	-2	PART NO	DESCRIPTION	ITEM NO

ATLANTIC VERSION
 Shown on sheets 1 of 4 & 2 of 4
 (Pacific version shown on sheets 3 of 4 & 4 of 4)

SET UP GAUGE	LOC	DIST	REVISIONS				
2119599-2	A	66	REV	DATE	BY	APPD	
			A	RELEASED	14DEC2015	RK	GB

-	1	-	1	1	1-22279-3	SPRING, COMPRESSION	246
-	-	1	-	-	2119759-1	RAM, AMP STYLE, END FEED, NON-ADJUST	245
-	1	1	1	1	2119082-8	CAM, SNAIL, INSULATION ADJUSTMENT	244
-	1	1	1	1	2079764-1	WASHER, WAVE SPRING, CREST-TO-CREST	243
-	1	1	1	1	2119083-1	RETAINER, INSULATION DIAL	242
-	-	2	2	-	2168400-7	SHCS, LOW HEAD, RoHS, M5 X 10	240
-	-	-	-	1	2063440-2	AIR FEED MODULE	238
-	-	1	1	-	2119740-2	TAG, IDENTIFICATION	213
-	1	1	1	1	1803203-1	BLOCK, FRONT DEPRESSOR	185
-	-	REFREF	-	-	1901697-1	FEED FINGER ASSEMBLY, EF	183
-	1	1	1	1	1752354-2	STANDOFF, HOLD-DOWN	180
-	1	1	1	1	6-993111-6	PIN, SLOTTED SPRING 3.0 X 14.0	177
-	1	1	1	1	8-22280-7	SPRING, COMPRESSION	176
-	1	1	1	1	1752353-2	GUIDE PIN, HOLDDOWN	175
-	1	1	1	1	1901680-2	GUIDE PIN, HOLDDOWN	174
-	-	-	-	2	21045-3	RING, RETAIN, EXTERN, 3/16 CRESCENT	172
-	1	1	1	1	994969-1	MAGNET, RARE EARTH HIGH ENERGY	166
-	REFREF	REFREF	REFREF	REFREF	994970-2	COUNTER, MAGNETIC	164
-	-	-	-	1	240638-1	SPRING, FEED FINGER	163
-	-	-	-	1	3-23627-7	PIN, RETAIN, GRVD, 3/16 X .854	137
-	-	REFREF	-	-	SEE NOTE 4	MEMORY CHIP, PROGRAMMED	135
-	-	1	1	-	1633743-1	SERVO FEED LATCH ASM	133
-	1	1	1	1	1-455888-0	SPACER, CRIMPER	120
-	1	1	1	1	2119955-2	ASSY, LUBRICATOR, END FEED	84
-	1	1	1	1	1-455888-0	SPACER, CRIMPER	82
-	1	1	1	1	1-2119791-1	DEPRESSOR, WIRE	73
-	1	1	1	1	2119956-2	DOCUMENTATION PACKAGE	71
-	2	2	2	2	2-18032-2	SCR, SET, FLT POINT M3 X 10.0	70
-	1	1	1	1	2119943-1	WASHER, SPACER	69
-	1	-	-	1	2119740-1	TAG, IDENTIFICATION	67
-	2	2	2	2	2168078-1	SCREW, DRIVE, RH, RoHS, 2 x .188	66
-	1	1	1	1	1901681-1	HOLDDOWN, TERMINAL	65
-	1	-	-	1	2119793-1	LIMITER, ADJUSTMENT BOLT	63
-	3	-	3	3	992763-5	SCR, SET, SOC, CONE POINT, M3 X 4.0	62
-	1	1	1	1	2079383-4	SCR, BHSC, RoHS (M4 X 8)	60
-	4	4	4	4	2168400-4	SHCS, LOW HEAD, RoHS, M4 X 8	57
-	2	2	2	2	2168083-8	SCR, SKT HD CAP, RoHS, M4 X 16	56
-	2	2	2	2	5018030-1	NUT, HEX, REG, RoHS, M3	54
-	2	2	2	2	986965-8	NUT, LOCK, HEX, TORQUE (M4)	53
-	1	1	1	1	1-5018030-0	NUT, HEX, REG, RoHS, M3.5	52
-	-	-	-	1	2119792-2	PAWL, EF, AIR	51
-	-	-	-	1	18023-9	SCR, SKT HD CAP M4 X 6.0	49
-	1	1	1	1	2119655-5	APPLICATOR BASIC ASSEMBLY, EF	46
-	1	-	-	1	2119369-1	RAM, AMP STYLE, END FEED	44
-	1	1	1	1	2079383-7	SCR, BHSC, RoHS (M8 X 25)	41
-	1	-	-	1	2119645-1	DISC, NUMBERED FA WIRE ADJUSTMENT	40
-	1	-	-	1	2119957-1	APPLICATOR SHIM PACK	39
-	1	1	1	1	2119644-3	RAM WASHER, PRECISION	38
-	1	1	1	1	2119085-1	FA HEAD, ATLANTIC STYLE	37
-	1	-	-	1	2119092-1	BOLT, ADJUSTMENT	35
-	8	8	8	8	1-18028-2	WASHER, FLAT, REG M4	33
-	2	2	2	2	2168083-9	SCR, SKT HD CAP, RoHS, M4 X 20	31
-	2	2	2	2	2168083-2	SCR, SKT HD CAP, RoHS, M4 X 8.0	29
-	1	1	1	1	240639-1	STRIPPER (MACHINING)	27
-	2	2	2	2	1-2168083-6	SCR, SKT HD CAP, RoHS, M4 X 35	25
-	1	1	1	1	1752371-5	PLATE, STRIP GUIDE	24
-	2	2	2	2	2-22281-3	SPRING, COMPRESSION	22
-	1	1	1	1	1803292-8	DRAG	20
-	1	1	1	1	1901696-4	STRIP GUIDE, REAR	19
-	1	1	1	1	1901695-4	STRIP GUIDE, FRONT	18
-	4	4	4	4	1-2079383-1	SCR, BHSC, RoHS (M6 X 12)	17
-	1	1	1	1	1752360-1	SPACER, HOLD-DOWN	13
-	1	1	1	1	240644-1	PLATE, REAR SHEAR	11
-	-	-	-	-	-	-	10
-	1	1	1	1	690482-7	PLATE, FRONT SHEAR	9
-	1	1	1	1	8-1803001-7	ANVIL, COMBINATION, END FEED	8
-	1	1	1	1	1-2217206-6	BLADE, SLUG	7
-	-	-	-	-	-	-	6
-	1	1	1	1	5-240641-3	SPACER	5
-	1	1	1	1	1-238011-2	BLOCK, CRIMPER SPACER	4
-	1	1	1	1	3-2119582-1	CRIMPER, INSULATION F PREMIUM	3
-	1	1	1	1	455888-8	SPACER, CRIMPER	2
-	1	1	1	1	1-456430-7	CRIMPER, WIRE	1
-77	-7	-6	-5	-2	PART NO	DESCRIPTION	ITEM NO

DIMENSIONS:		TOLERANCES UNLESS OTHERWISE SPECIFIED:		DWG		NAME	
mm	0 PLC ±	1 PLC ±	2 PLC ±	3 PLC ±	4 PLC ±	5 PLC ±	ANGLES ±
	FINISH						
MATERIAL		WEIGHT		SCALE	1:1	SHEET	1 OF 4
Customer Accessible Production Drawing				REV A			

LOC	DIST	REV	DESCRIPTION	DATE	DWN	APVD
A	66	-	SEE SHEET 1	-	-	-

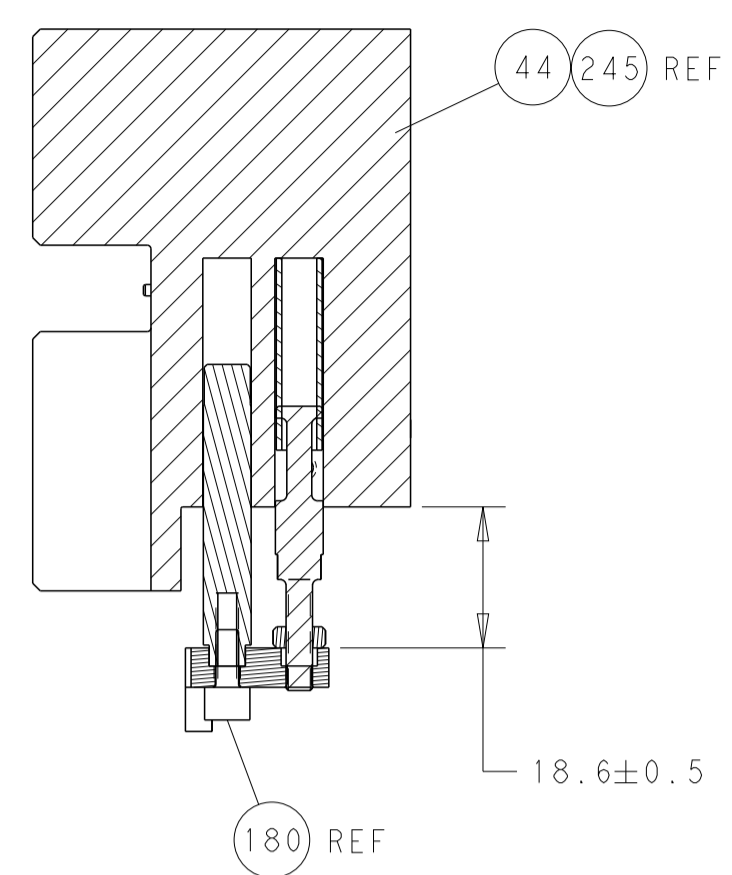

HOLDDOWN SET-UP

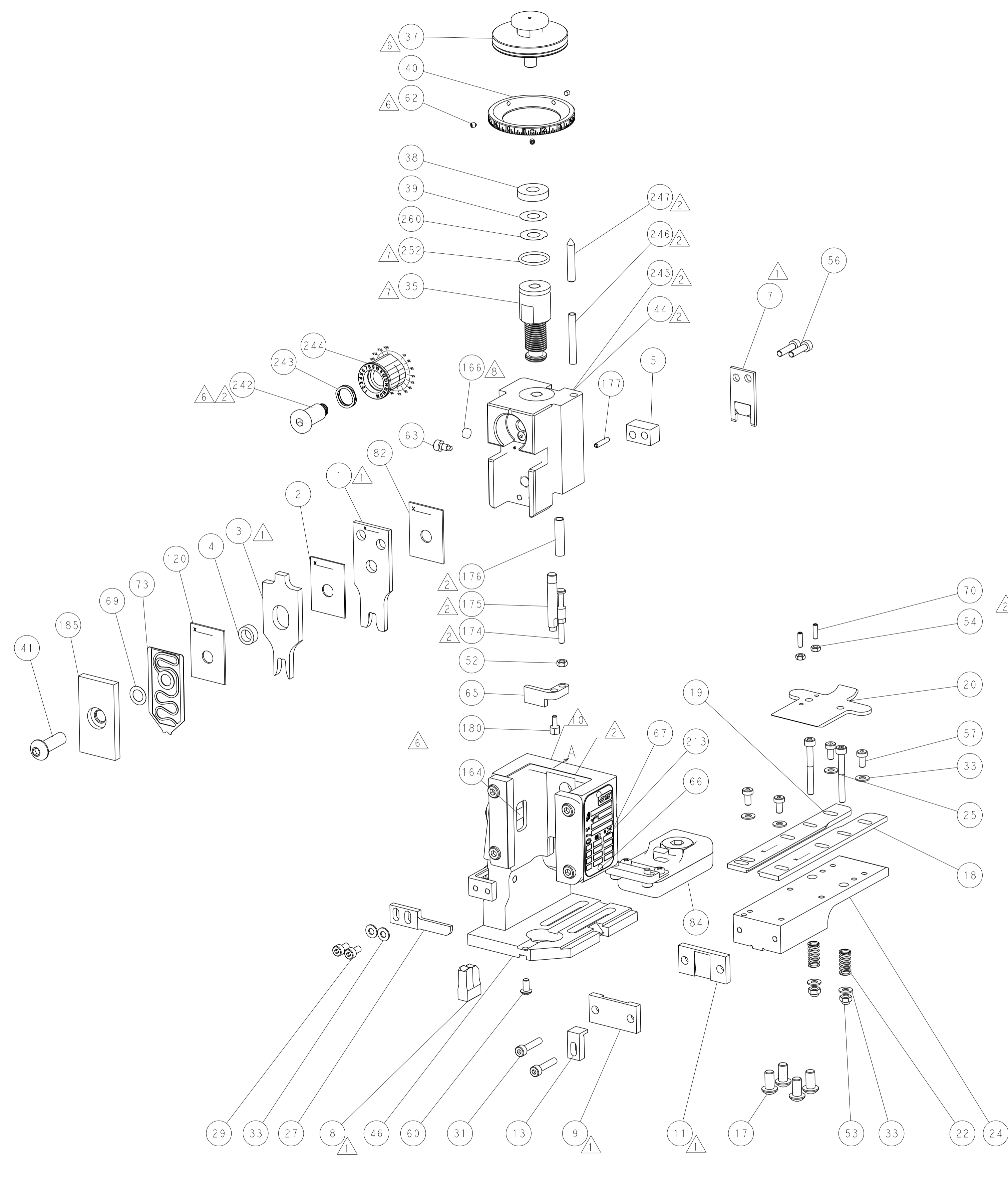

FEED TYPE

PNEUMATIC

SERVO LATCH PLATE

CAM POSITION

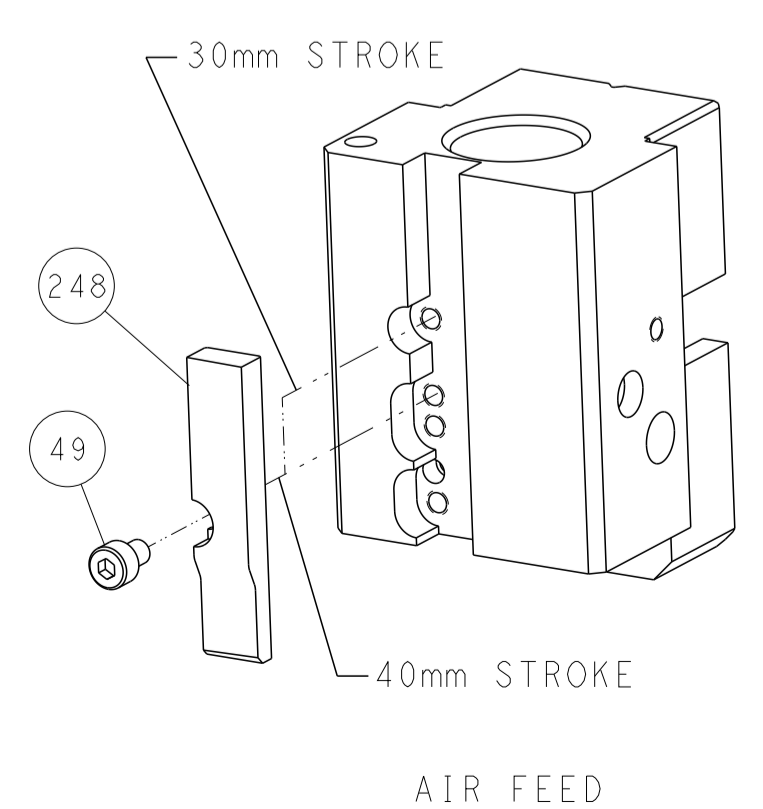

AIR FEED

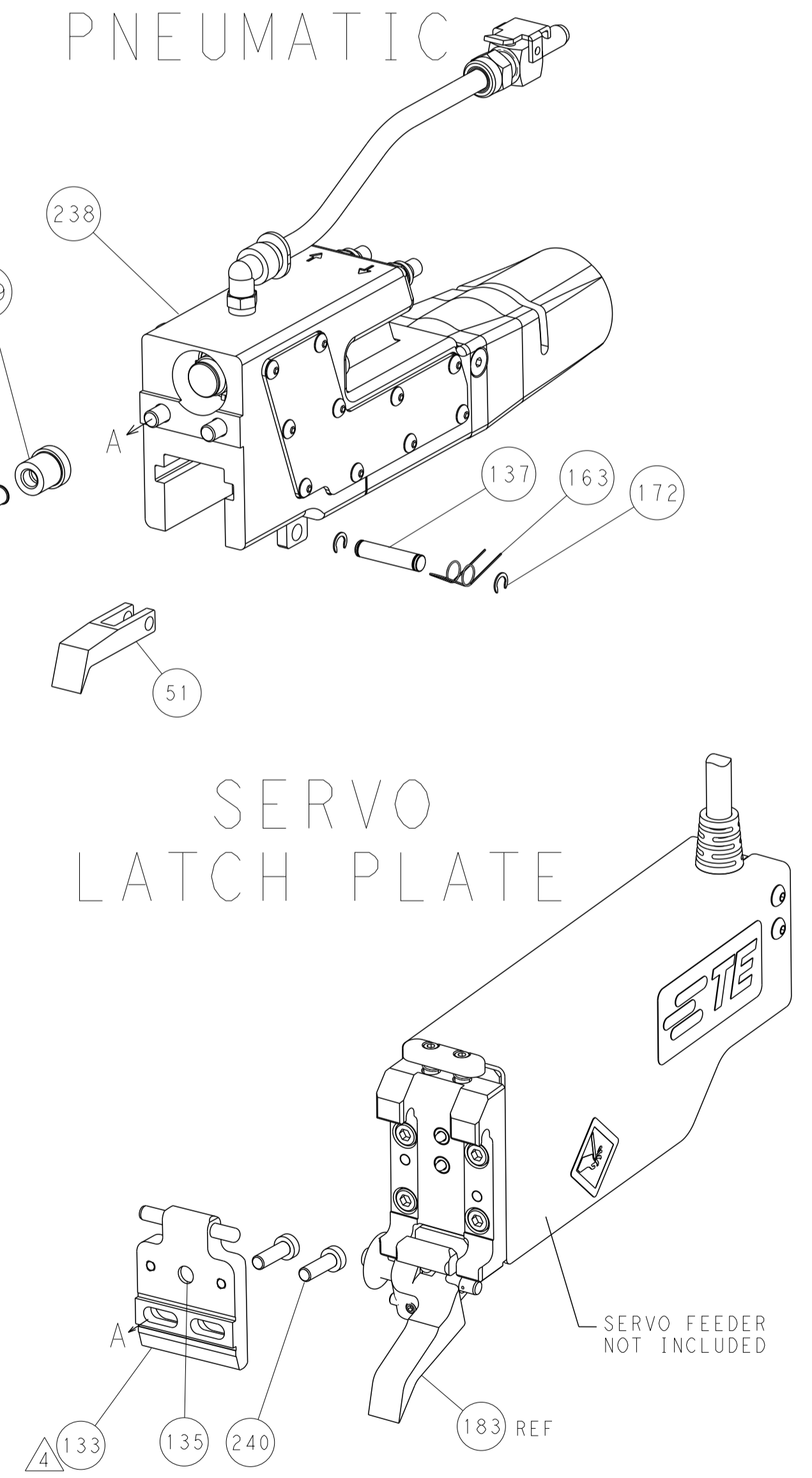

ATLANTIC VERSION
 Shown on sheets 1 of 4 & 2 of 4
 (Pacific version shown on sheets 3 of 4 & 4 of 4)

DIMENSIONS:		TOLERANCES UNLESS OTHERWISE SPECIFIED:		REVISIONS	
mm	0 PLC	±	08JUL2015	OWN	B. WEAVER
	1 PLC	±	08JUL2015	CHK	T. ELBIN
	2 PLC	±	08JUL2015	APVD	T. ELBIN
	3 PLC	±		NAME	
	4 PLC	±		PRODUCT SPEC	
	ANGLES	±		APPLICATION SPEC	
	FINISH	±		SIZE	CAGE CODE
MATERIAL				WEIGHT	DRAWING NO.
					RESTRICTED TO

Customer Accessible Production Drawing SCALE 1:1 SHEET 2 OF 4 REV A

PACIFIC VERSION TERMINATOR INTERFACE ADAPTER	PART NUMBER	REVISION	DESCRIPTION	FEED TYPE	APPLICATOR STYLE CONVERSION CHART					
					CONVERT TO	PART NUMBERS REQUIRED				
	2-2150585-2	A	FINE CRIMP HEIGHT ADJUST	PNEUMATIC	-	-	-	-	-	-
					SERVO LATCH PLATE	2119951-1	1901697-1	8-2150585-5	-	-
	2-2150585-5	A	FINE CRIMP HEIGHT ADJUST	SERVO LATCH PLATE ⁴	-	-	-	-	-	-
					PNEUMATIC FEED	2119950-1	2119792-2	-	2119641-2	-
2-2150585-7	A	FINE CRIMP HEIGHT ADJUST	NONE	-	-	-	-	-	-	
7-2150585-7	A	CRIMP TOOLING KIT	-	-	-	-	-	-	-	

APPLICATOR DATA		
CRIMP	SIZE	TYPE
WIRE	5.33 mm [.210]	F
INSUL	6.35 mm [.250]	F
APPL INSTRUCTIONS 408-10390		

TERMINAL DATA: TE TERMINAL		TE CRIMP SPECIFICATION
TERMINAL NAME: RING TONGUE		
WIRE STRIP LENGTH		INSULATION DIAMETER RANGE
3.56-4.36 mm [.140-.172 IN]		∅3.81-5.33 mm [.150-.210 IN]
TERMINAL APPLICATION SPECIFICATION	114-2084	-
TERMINALS APPLIED ¹⁰		
TE TERMINAL	TE TERMINAL	TE TERMINAL
140651	140653	140656
140652	140655	

WIRE SIZE	CRIMP HEIGHT mm [INCH]	CRIMP HEIGHT REFERENCE SETTING ⁹
10 AWG	2.87+/-0.05 [.113+/- .002]	6.1
12 AWG	2.59+/-0.05 [.102+/- .002]	8.9



- ¹ RECOMMENDED SPARE PARTS
- ² GREASE BEARING SURFACES LIGHTLY
- 3. LUBRICATE DAILY PER THE APPLICATOR INSTRUCTION SHEET SUPPLIED WITH THE APPLICATOR.
- ⁴ APPLICATOR SPECIFIC DATA TO BE ENTERED INTO BLANK MEMORY CHIP AT ASSEMBLY. SEE BELOW FOR PART NUMBER:
PNEUMATIC FEED WITH "SMART APPLICATOR" CONVERSION: 8-2150585-4
SERVO FEED WITH "FINE CRIMP HEIGHT ADJUST": 8-2150585-5
- 5. ADJUSTMENT OF THE STRIPPER MAY BE REQUIRED WHEN MOVING THE APPLICATOR BETWEEN BENCH AND LEADMAKER APPLICATIONS.
- ⁶ APPLY PART NUMBER 1-23419-5 LOCTITE TO THREADS OF ITEMS 62 & 180. APPLY PART NUMBER 2-23419-6 LOCTITE TO THREADS OF ITEM 242.
- ⁷ GREASE THREADS, GROOVE AND O-RING ON ITEMS 139 & 153.
- ⁸ MAGNET, ITEM 166 MUST BE ORIENTED CORRECTLY IN ORDER TO PROPERLY ACTUATE THE COUNTER.
- ⁹ CRIMP HEIGHT REFERENCE SETTING WAS THE SETTING USED WHEN THE APPLICATOR WAS QUALIFIED AT THE FACTORY. ADJUSTMENT MAY BE NECESSARY WHEN RUNNING APPLICATOR IN THE FIELD.
- ¹⁰ TERMINAL PITCH NOT COMPATIBLE WITH MECHANICAL FEED.
- ¹¹ THE RECOMMENDED SET-UP FOR END FEED APPLICATORS IS POST-FEED WITH ITEM 2119653-1. THE APPLICATOR CAN BE CONFIGURED FOR PRE-FEED WITH ITEM 2119652-1 BUT MAY ENCOUNTER PROBLEMS WITH SOME APPLICATIONS. FEED ISSUES OR TERMINAL JAMMING MAY OCCUR IN THE PRE-FEED CONFIGURATION.

***WARNING**
ON INSTALLATION, SET WIRE DISC, ITEM 40 TO LARGEST WIRE SIZE SETTING. USE OF SETTINGS BELOW MINIMUM REQUIRED CRIMP HEIGHT SETTING WILL CAUSE DAMAGE TO CRIMP TOOLING.

-77-27-25-22	PART NO	DESCRIPTION	ITEM NO
- 1 1 1	2119782-1	FINE ADJUST HEAD ASM, PACIFIC STYLE	251
- - - 1	2119640-1	PUSH ROD, AIR FEED	250
- - - 1	2079988-1	BUSHING, LCH5-12, MISUMI	249
- 1 1 1	1-22279-3	SPRING, COMPRESSION	246
- 1 1 1	2119082-8	CAM, SNAIL, INSULATION ADJUSTMENT	244

PACIFIC VERSION
Shown on sheets 3 of 4 & 4 of 4
(Atlantic version shown on sheets 1 of 4 & 2 of 4)

SET UP GAUGE	LOC	DIST	REVISIONS			
2119599-2	A	66	REV	DATE	BY	APPV
			-	SEE SHEET 1	-	-

- 1 1 1	2079764-1	WASHER, WAVE SPRING, CREST-TO-CREST	243
- 1 1 1	2119083-1	RETAINER, INSULATION DIAL	242
- - 2 -	2168400-7	SHCS, LOW HEAD, RoHS, M5 X 10	240
- - - 1	2063440-2	AIR FEED MODULE	238
- - 1 -	2119740-2	TAG, IDENTIFICATION	213
- 4 4 4	2079383-9	SCR, BHSC, RoHS (M6 X 20)	186
- 1 1 1	1803203-1	BLOCK, FRONT DEPRESSOR	185
- - REF -	1901697-1	FEED FINGER ASSEMBLY, EF	183
- 1 1 1	1752354-2	STANDOFF, HOLD-DOWN	180
- 1 1 1	6-993111-6	PIN, SLOTTED SPRING 3.0 X 14.0	177
- 1 1 1	8-22280-7	SPRING, COMPRESSION	176
- 1 1 1	1752353-2	GUIDE PIN, HOLDDOWN	175
- 1 1 1	1901680-2	GUIDE PIN, HOLDDOWN	174
- - - 2	21045-3	RING, RETAIN, EXTERN, 3/16 CRESCENT	172
- 1 1 1	994969-1	MAGNET, RARE EARTH HIGH ENERGY	166
- REF REF REF	994970-2	COUNTER, MAGNETIC	164
- - - 1	240638-1	SPRING, FEED FINGER	163
- 1 1 1	8-21084-1	O-RING, .801 ID, .070 DIA. MAT.	153
- - - 1	2119641-2	FEED CAM, AIR FEED	152
- 1 1 1	2119798-2	DETENT PIN	145
- 1 1 1	2079383-8	SCR, BHSC, RoHS (M4 X 16)	144
- 1 1 1	2119655-6	APPLICATOR BASIC ASSEMBLY, EF	141
- 1 1 1	2119651-1	RAM, ASIAN STYLE, END FEED	140
- 1 1 1	2119092-2	BOLT, ADJUSTMENT	139
- - - 1	3-23627-7	PIN, RETAIN, GRVD, 3/16 X .854	137
- - REF -	SEE NOTE 4	MEMORY CHIP, PROGRAMMED	135
- - 1 -	1633743-1	SERVO FEED LATCH ASM	133
- 1 1 1	1-455888-0	SPACER, CRIMPER	120
- 1 1 1	2119955-2	ASSY, LUBRICATOR, END FEED	84
- 1 1 1	1-455888-0	SPACER, CRIMPER	82
- 1 1 1	1-2119791-1	DEPRESSOR, WIRE	73
- 1 1 1	2119956-2	DOCUMENTATION PACKAGE	71
- 2 2 2	2-18032-2	SCR, SET, FLT POINT M3 X 10.0	70
- 1 1 1	2119943-1	WASHER, SPACER	69
- 1 - 1	2119740-1	TAG, IDENTIFICATION	67
- 2 2 2	2168078-1	SCREW, DRIVE, RH, RoHS, 2 x .188	66
- 1 1 1	1901681-1	HOLDDOWN, TERMINAL	65
- 1 1 1	2119793-1	LIMITER, ADJUSTMENT BOLT	63
- 3 3 3	992763-5	SCR, SET, SOC, CONE POINT, M3 x 4.0	62
- 4 4 4	2168400-4	SHCS, LOW HEAD, RoHS, M4 X 8	57
- 2 2 2	2168083-8	SCR, SKT HD CAP, RoHS, M4 X 16	56
- 2 2 2	5018030-2	NUT, HEX, REG, RoHS, M4	55
- 2 2 2	5018030-1	NUT, HEX, REG, RoHS, M3	54
- 2 2 2	986965-8	NUT, LOCK, HEX, TORQUE (M4)	53
- 1 1 1	1-5018030-0	NUT, HEX, REG, RoHS, M3.5	52
- - - 1	2119792-2	PAWL, EF, AIR	51
- - - 1	18023-9	SCR, SKT HD CAP M4 X 6.0	49
- 1 1 1	2079383-7	SCR, BHSC, RoHS (M8 X 25)	41
- 1 1 1	2119645-1	DISC, NUMBERED FA WIRE ADJUSTMENT	40
- 1 1 1	2119957-1	APPLICATOR SHIM PACK	39
- 1 1 1	2119644-3	RAM WASHER, PRECISION	38
- 8 8 8	1-18028-2	WASHER, FLAT, REG M4	33
- 2 2 2	2168083-9	SCR, SKT HD CAP, RoHS, M4 X 20	31
- 2 2 2	2168083-2	SCR, SKT HD CAP, RoHS, M4 X 8.0	29
- 1 1 1	240639-1	STRIPPER (MACHINING)	27
- 2 2 2	1-2168083-6	SCR, SKT HD CAP, RoHS, M4 X 35	25
- 1 1 1	1752371-5	PLATE, STRIP GUIDE	24
- 2 2 2	2-22281-3	SPRING, COMPRESSION	22
- 1 1 1	1803292-8	DRAG	20
- 1 1 1	1901696-4	STRIP GUIDE, REAR	19
- 1 1 1	1901695-4	STRIP GUIDE, FRONT	18
- 1 1 1	1752360-1	SPACER, HOLD-DOWN	13
- 1 1 1	240644-1	PLATE, REAR SHEAR	11
- - - -	-	-	10
- 1 1 1	690482-7	PLATE, FRONT SHEAR	9
1 1 1 1	8-1803001-7	ANVIL, COMBINATION, END FEED	8
- 1 1 1	1-2217206-6	BLADE, SLUG	7
- - - -	-	-	6
- 1 1 1	5-240641-3	SPACER	5
- 1 1 1	1-238011-2	BLOCK, CRIMPER SPACER	4
1 1 1 1	3-2119582-1	CRIMPER, INSULATION F PREMIUM	3
- 1 1 1	455888-8	SPACER, CRIMPER	2
1 1 1 1	1-456430-7	CRIMPER, WIRE	1

DIMENSIONS:		TOLERANCES UNLESS OTHERWISE SPECIFIED:		DWG		CHK		APPV		NAME	
mm	0 PLC ±	1 PLC ±	2 PLC ±	3 PLC ±	4 PLC ±	5 PLC ±	6 PLC ±	7 PLC ±	8 PLC ±	9 PLC ±	10 PLC ±
	ANGLES	FINISH									
MATERIAL		WEIGHT		SIZE	CAGE CODE	DRAWING NO	RESTRICTED TO	Customer Accessible Production Drawing			
				A1	00779	©=2150585		SCALE 1:1 SHEET 3 OF 4 REV A			

LOC		DIST		REVISIONS			
A	66	P	LTH	DESCRIPTION	DATE	OWN	APVD
		-		SEE SHEET 1			

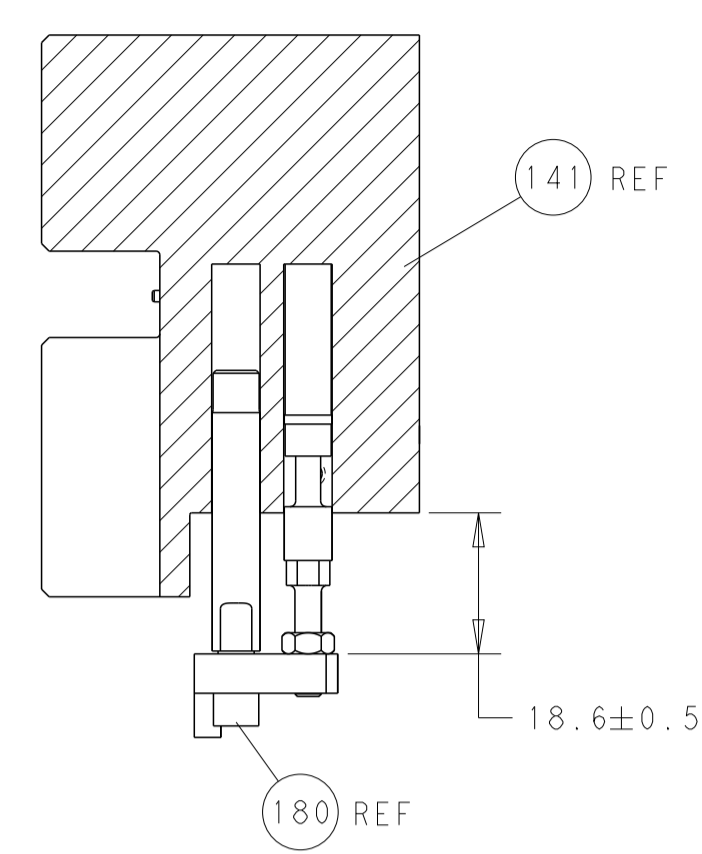

HOLDDOWN SET-UP

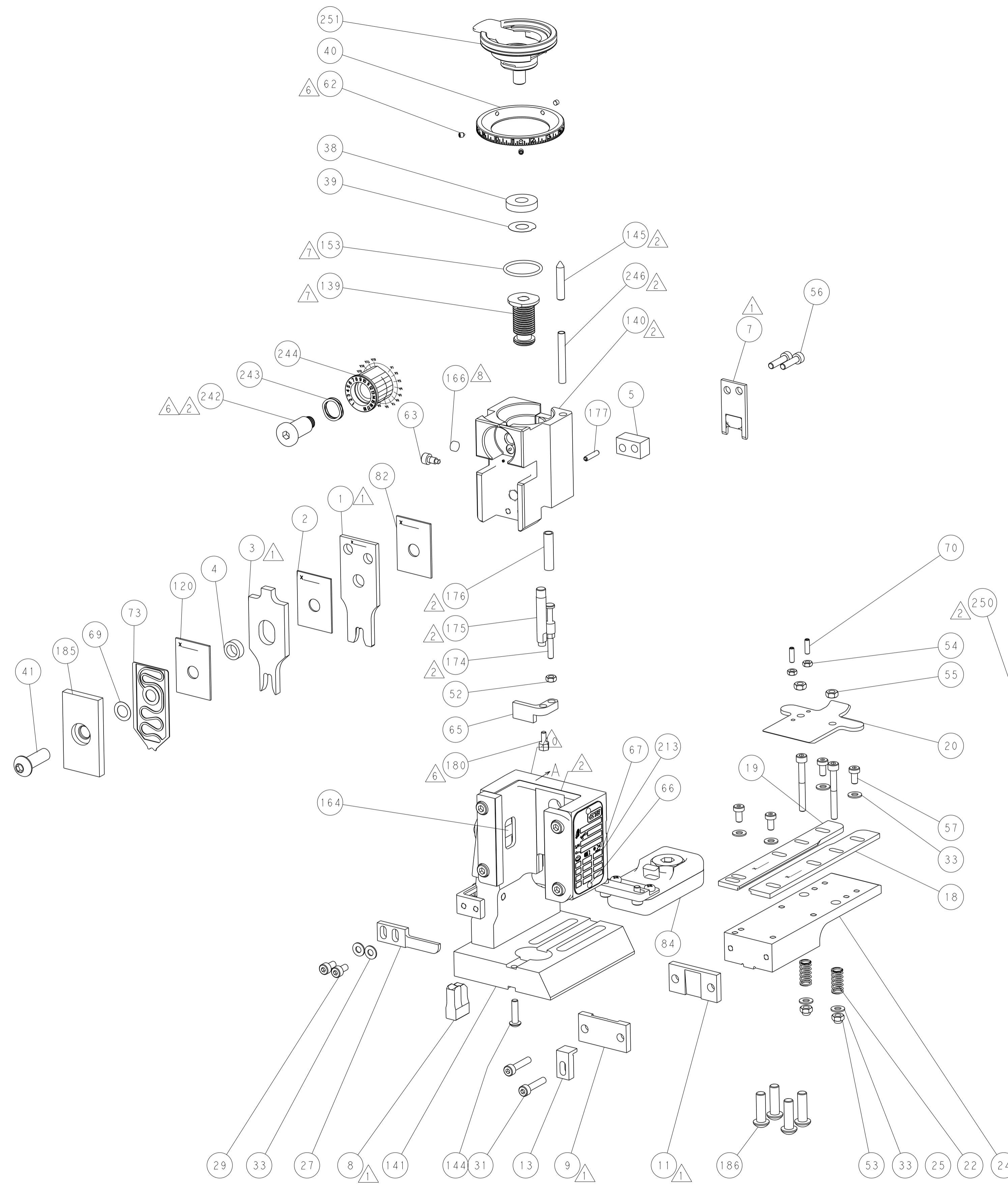

FEED TYPE

PNEUMATIC

SERVO LATCH PLATE

CAM POSITION

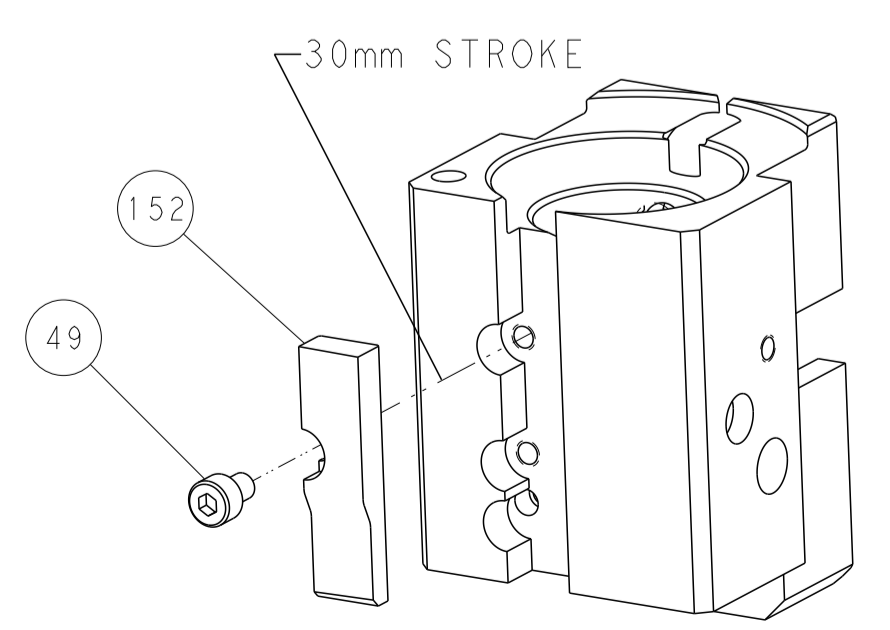

AIR FEED

PACIFIC VERSION
 Shown on sheets 3 of 4 & 4 of 4
 (Atlantic version shown on sheets 1 of 4 & 2 of 4)

<small>THIS DRAWING IS UNPUBLISHED. RELEASED FOR PUBLICATION 2015. COPYRIGHT 2015 BY TYCO ELECTRONICS CORPORATION. ALL RIGHTS RESERVED.</small>		DWN: B. WEAVER 08JUL2015 CHK: T. ELBIN 08JUL2015 APVD: T. ELBIN 08JUL2015	NAME: TE Connectivity Harrisburg, PA 17105-3608
DIMENSIONS: mm TOLERANCES UNLESS OTHERWISE SPECIFIED: 0 PLC ± 1 PLC ± 2 PLC ± 3 PLC ± 4 PLC ± ANGLES ± FINISH	DIMENSIONS: mm TOLERANCES UNLESS OTHERWISE SPECIFIED: 0 PLC ± 1 PLC ± 2 PLC ± 3 PLC ± 4 PLC ± ANGLES ± FINISH	PRODUCT SPEC: APPLICATION SPEC: WEIGHT: A1 00779 SCALE: 1:1	NAME: Ocean End Feed Applicator SIZE: CAGE CODE DRAWING NO: 2150585 RESTRICTED TO: Customer Accessible Production Drawing
SHEETS 1 & 2 ARE NOT REQUIRED FOR PACIFIC VERSION		SHEET 4 OF 4	REV A