

GOLD CHIP THERMISTOR GA10K3CG1311

Description

High stability 10K nominal resistance NTC Gold Chip Thermistor for use in microelectronic applications and laser diode packages requiring long-term performance. With metallization on top and bottom surfaces, attachment to hybrid, IC or PC circuits is accomplished using industry standard die attach and wire bonding techniques. Chips may be soldered or bonded with conductive epoxy to board termination points where space is at a premium. MTTF reliability information is provided for the complete range of gold chip products for customer selection and design-in.

Features

- Gold electrodes suitable for wire bonding
- Mount directly to substrate for fast time-response
- Temperature range -40°C to $+125^{\circ}\text{C}$
- High stability performance with additional aging steps
- Delivers advanced electro-ceramic materials with fine grained microstructure
- Packed in waffle trays

Applications

- WDM (Wavelength Division Multiplexing) for advanced frequency control in communications systems and wireless applications
- Thermopile sensors for thermal radiation recognition and infrared sensing
- Thermal protection of sensitive circuits
- Hybrid circuit temperature compensation
- Localized temperature sensing
- Laser diode modules

High Density Ceramic Material

The Beta_{25/85} 3956 NTC electro-ceramic material is densified using state-of-the-art fabrication techniques. High pressure is applied during the ceramic fabrication process to enhance the mechanical properties of the ceramic. The temperature, pressure and process time are all precisely controlled to achieve the desired mechanical and electrical properties. The densification process effectively eliminates porosity and achieves near 100% theoretical density for the ceramic body. This densification process further enhances the performance of the NTC thermistor and the associated long-term stability.

Specifications

- 10K Ohms Resistance @ $+25^{\circ}\text{C}$
- $\pm 1\%$ Resistance Tolerance @ $+25^{\circ}\text{C}$
- Rapid Time Response
- Beta _{25/85} = $3956 \pm 1.0 \%$

[CLICK HERE >](#)
CONNECT WITH A SPECIALIST

GOLD CHIP THERMISTOR GA10K3CG1311

Performance specifications

Parameters	Units	Value
Resistance @ +25°C	Ohms	10,000
Resistance Tolerance @ +25°C	%	±1
Beta Value 25/85	K	3956
Tolerance on Beta Value 25/85	%	±1
Operating Temperature	°C	-40 to +125°C
Thermal Time Constant in Air *	Seconds	< 1.5
Dissipation Constant *	mW/°C	≥ 0.50
Maximum Power Dissipation *	mW	50

Note: Time Response and DC measurements performed with Alloy 180 Lead wires Ø 0.2mm (0.008”) soldered to chip

Mechanical details

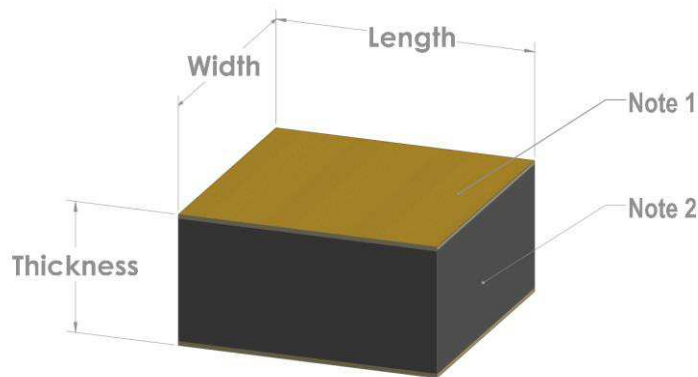

Dimensions

Thickness	Width	Length
0.36mm Min - 0.40mm Max	0.50mm Min - 0.60mm Max	0.50mm Min - 0.60mm Max

Notes

1	Gold Metallization - Top and Bottom electrodes
2	TE Electro Ceramic Material: BT647H-D

Reliability performance

Environmental Testing Data, TE Material BT647H-D Gold Chip NTC

Test	Test Conditions and Duration	Performance
High Temperature Exposure (T1)	<p>Exposure Temperature = +50°C</p> <p>Duration = 2,000 Hours</p> <p>Test specimens mounted on CerDIP package and placed in a hotbox oven.</p>	<p>Delta Resistance (%ΔR) @ +25°C after 2,000 hours exposure to Test Condition T1.</p> <p>Delta Resistance (%ΔR) calculated against 0-hour readings.</p> <p>Max allowable Delta = +/- 1%</p> <p>Result = Pass</p>
High Temperature Exposure (T2)	<p>Exposure Temperature = +75°C</p> <p>Duration = 2,000 Hours</p> <p>Test specimens mounted on CerDIP package and placed in a hotbox oven.</p>	<p>Delta Resistance (%ΔR) @ +25°C after 2,000 hours exposure to Test Condition T2.</p> <p>Delta Resistance (%ΔR) calculated against 0-hour readings.</p> <p>Max allowable Delta = +/- 1%</p> <p>Result = Pass</p>
High Temperature Exposure (T3)	<p>Exposure Temperature = +100°C</p> <p>Duration = 2,000 Hours</p> <p>Test specimens mounted on CerDIP package and placed in a hotbox oven.</p>	<p>Delta Resistance (%ΔR) @ +25°C after 2,000 hours exposure to Test Condition T3.</p> <p>Delta Resistance (%ΔR) calculated against 0-hour readings.</p> <p>Max allowable Delta = +/- 1%</p> <p>Result = Pass</p>
High Temperature Exposure (T4)	<p>Exposure Temperature = +125°C</p> <p>Duration = 2,000 Hours</p> <p>Test specimens mounted on CerDIP package and placed in a hotbox oven.</p>	<p>Delta Resistance (%ΔR) @ +25°C after 2,000 hours exposure to Test Condition T4.</p> <p>Delta Resistance (%ΔR) calculated against 0-hour readings.</p> <p>Max allowable Delta = +/- 1%</p> <p>Result = Pass</p>
Low Temperature Exposure	<p>Exposure Temperature = -40°C</p> <p>Duration = 1,000 Hours</p> <p>Test specimens mounted on CerDIP package and placed in a low temperature chamber. Test specimens allowed to stand under ambient conditions for 2 hours +/- 1 hour prior to zero-power resistance check.</p>	<p>Delta Resistance (%ΔR) @ +25°C after 1,000 hours exposure to test condition.</p> <p>Delta Resistance (%ΔR) calculated against 0-hour readings.</p> <p>Max allowable Delta = +/- 1%</p> <p>Result = Pass</p>

Environmental Testing Data, TE Material BT647H-D Gold Chip NTC

Test	Test Conditions and Duration	Performance
<p>Humidity Storage Test</p>	<p>Exposure Condition = +85°C at 85% Relative Humidity Duration = 1,000 Hours</p> <p>Test specimens mounted on CerDIP package and placed in a humidity chamber. Test specimens allowed to stand under ambient conditions for 2 hours +/- 1 hour prior to zero-power resistance check.</p>	<p>Delta Resistance (%ΔR) @ +25°C after 1,000 hours exposure to test condition.</p> <p>Delta Resistance (%ΔR) calculated against 0-hour readings.</p> <p>Max allowable Delta = +/- 1%</p> <p>Result = Pass</p>
<p>Thermal Shock Test</p>	<p>Thermal Shock = -40°C to +85°C 30 mins @ -40°C ---> 5 sec transfer ---> +85°C Total Cycle Time = 1 hour Number of Thermal Shock Cycles = 1,000</p> <p>Test specimens mounted on CerDIP package and placed in a Thermal Shock Chamber.</p>	<p>Delta Resistance (%ΔR) @ +25°C after 1,000 Thermal Shock Cycles.</p> <p>Delta Resistance (%ΔR) calculated against 0-Cycle Thermal Shock readings.</p> <p>Max allowable Delta = +/- 1%</p> <p>Result = Pass</p>
<p>High Temperature Power Loading</p>	<p>Exposure Condition = +100°C Supply Voltage +0.11VDC Duration = 1,000 Hours</p> <p>Test specimens mounted on CerDIP package and placed in a high temperature chamber with DC voltage applied.</p>	<p>Delta Resistance (%ΔR) @ +25°C after 1,000 hours exposure to test condition.</p> <p>Delta Resistance (%ΔR) calculated against 0-hour readings.</p> <p>Max allowable Delta = +/- 1%</p> <p>Result = Pass</p>
<p>Wire Bond Strength</p>	<p>Wire Bond Strength testing conducted as per MIL-STD-883, Test Method 2011, Section 3.1.3, Test Condition D - Wire pull (double bond).</p> <p>25μm Au wire bonded to top electrode of NTC Gold Chip using ball bonding process. Wire Bond Strength testing performed using a Dage Series 4000 Bond tester.</p>	<p>Test specimens exceeded the MIL-STD-883, Method 2011, minimum strength of 3.00g.</p> <p>Result = Pass</p>
<p>Die Shear Strength</p>	<p>Die Shear Strength testing conducted to assess the integrity of the die-to-bonding pad interface as per MIL-STD-883, Test Method 2019, Section 3.2.1 Epoxy Attach & Figure 2019-4 (Die Shear Strength Criteria).</p> <p>Die attach material is silver loaded epoxy (Epo-Tek H35-175MPLV). Die Shear testing performed using a Dage Series 4000 Bond tester.</p>	<p>Test specimens exceeded the MIL-STD-883, Method 2019, minimum strength of 375.10g.</p> <p>Result = Pass</p>

Reliability and Lifetime:

The Gold Chip Thermistor operating lifetime has been calculated using accelerated life test principles. For the tests, the specimens were mounted in CerDIP packages using a silver filled epoxy to form the mechanical, thermal and electrical bond to the substrate. A gold wire bond was used to connect to the top electrode. The thermistors were subjected to unpowered storage at select temperatures between +50°C and +125°C. Periodic calibrations were taken to understand drift in resistance over time. Based on this data, a lifetime prediction model was applied to estimate Mean Time To Failure (MTTF) for operation at typical application temperatures. The criteria for failure was drift in resistance values at a reference temperature of +25°C with the model being applied for different allowable percentage drift values, as indicated below:

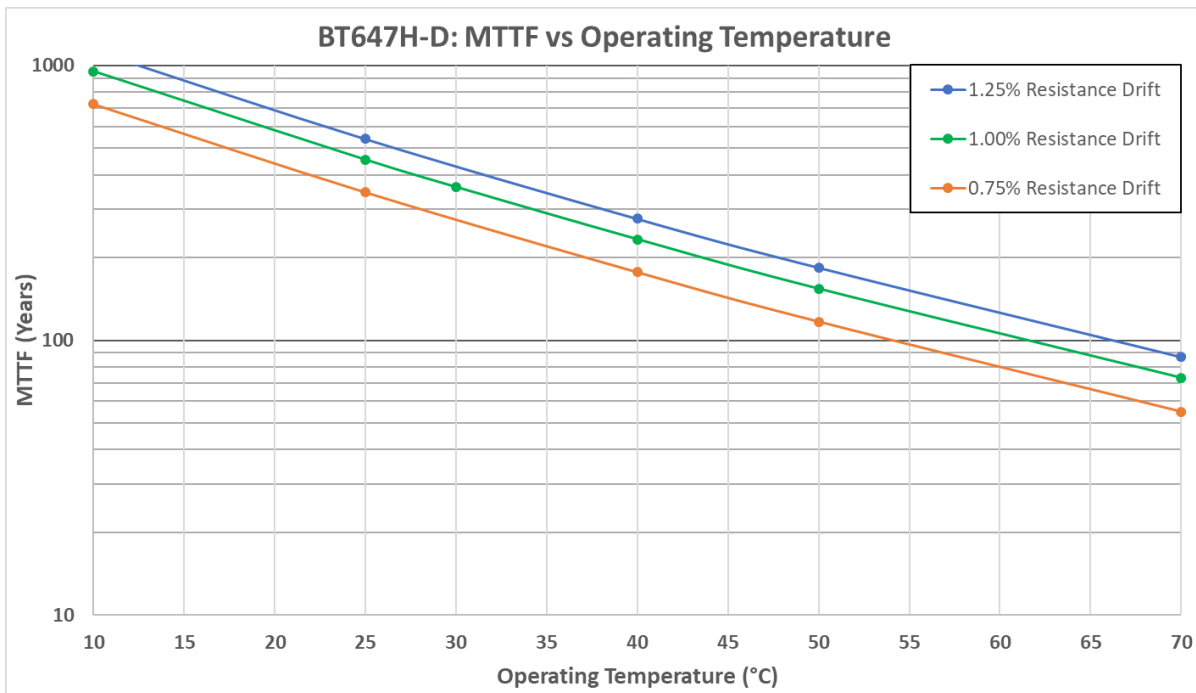

GOLD CHIP THERMISTOR GA10K3CG1311

Product packaging – waffle tray H20-025-18-66C02

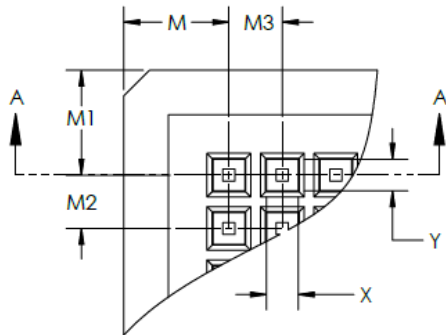

Pocket Locations

- M = $4.33 \pm 0.08\text{mm}$
- M1 = $4.33 \pm 0.08\text{mm}$
- M2 = $2.01 \pm 0.05\text{mm}$
- M3 = $2.01 \pm 0.05\text{mm}$
- Array = 22x22 (484)

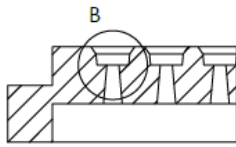

SECTION A-A

Pocket Details

- X = 0.64mm pocket size
- Y = 0.64mm pocket size
- Z = 0.46mm pocket depth
- A = $5^\circ \pm 1/2^\circ$ pocket draft angle

No cross slots

Overall Tray Size

- Size = $50.80 \pm 0.10\text{mm}$
- Height = $3.96 + 0.05\text{mm} - 0.08\text{mm}$
- Flatness = 0.10mm

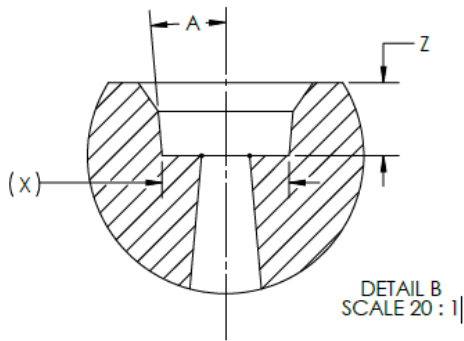

Resistance v temperature table

Temp °C	Ohms
-40	336,852.5
-39	315,281.0
-38	295,229.1
-37	276,580.5
-36	259,228.3
-35	243,074.6
-34	228,029.4
-33	214,009.8
-32	200,939.9
-31	188,749.5
-30	177,374.3
-29	166,754.9
-28	156,836.6
-27	147,569.1
-26	138,905.7
-25	130,803.6
-24	123,223.1
-23	116,127.6
-22	109,483.4
-21	103,259.0
-20	97,425.6
-19	91,956.4
-18	86,826.6
-17	82,013.1
-16	77,494.8
-15	73,251.8
-14	69,265.8
-13	65,519.8
-12	61,998.0
-11	58,685.8
-10	55,569.6
-9	52,636.6
-8	49,875.1
-7	47,274.2
-6	44,823.6
-5	42,513.8
-4	40,335.9
-3	38,281.8
-2	36,343.7
-1	34,514.5
0	32,787.5
1	31,148.7

Temp °C	Ohms
2	29,601.9
3	28,141.4
4	26,761.9
5	25,458.4
6	24,226.2
7	23,061.2
8	21,959.1
9	20,916.4
10	19,929.4
11	18,994.8
12	18,109.6
13	17,270.9
14	16,476.0
15	15,722.4
16	15,007.6
17	14,329.5
18	13,686.0
19	13,075.2
20	12,495.1
21	11,944.1
22	11,420.5
23	10,923.0
24	10,449.9
25	10,000.0
26	9,572.0
27	9,164.8
28	8,777.2
29	8,408.1
30	8,056.7
31	7,721.9
32	7,402.8
33	7,098.7
34	6,808.8
35	6,532.4
36	6,268.6
37	6,017.0
38	5,776.8
39	5,547.6
40	5,328.6
41	5,119.5
42	4,919.8
43	4,728.9

Temp °C	Ohms
44	4,546.4
45	4,371.9
46	4,205.1
47	4,045.5
48	3,892.8
49	3,746.7
50	3,606.9
51	3,473.3
52	3,345.4
53	3,222.9
54	3,105.5
55	2,993.1
56	2,885.3
57	2,782.0
58	2,682.9
59	2,587.9
60	2,496.8
61	2,409.4
62	2,325.5
63	2,244.9
64	2,167.6
65	2,093.3
66	2,022.0
67	1,953.5
68	1,887.6
69	1,824.3
70	1,763.5
71	1,705.0
72	1,648.8
73	1,594.7
74	1,542.6
75	1,492.5
76	1,444.3
77	1,397.9
78	1,353.2
79	1,310.2
80	1,268.8
81	1,228.8
82	1,190.4
83	1,153.3
84	1,117.6
85	1,083.1

Temp °C	Ohms
86	1,049.9
87	1,017.9
88	987.0
89	957.2
90	928.4
91	900.7
92	873.9
93	848.0
94	823.0
95	798.9
96	775.6
97	753.1
98	731.4
99	710.4
100	690.1
101	670.5
102	651.5
103	633.2
104	615.4
105	598.3
106	581.7
107	565.6
108	550.1
109	535.0
110	520.5
111	506.4
112	492.8
113	479.6
114	466.8
115	454.4
116	442.4
117	430.7
118	419.5
119	408.5
120	397.9
121	387.7
122	377.7
123	368.1
124	358.7
125	349.6

GOLD CHIP THERMISTOR GA10K3CG1311

Mounting recommendations using Au Sn eutectic solders

Recommended eutectic gold-tin alloy is 80%Au/20%Sn with a melt point of +280°C (556°F). High thermal conductivity of 80%Au/20%Sn solders increases the responsiveness of the NTC gold thermistor.

- Max ramp rate of 40°C per minute to a preheat temperature of +180°C to +200°C
- Preheat dwell period of 90 – 150 seconds @ +180°C to +200°C
- Maximum time above the eutectic temperature of +280°C for 45 seconds with a bell-shaped profile — no plateau at peak temperature of +300°C to +305°C
- Maximum time above peak temperature of +300°C for 8 seconds.
- Max cooling rate of 40°C per minute or less to prevent thermal stress on the component.
- Times indicated are based on the NTC surface temperature.

Excessive soldering temperatures and durations can cause leaching of the termination resulting in changes to the electrical characteristics of the NTC caused by reduction in adherence strength. The recommended profile is provided as a guideline only and it is recommended the customer validates the suitability for the intended purpose.

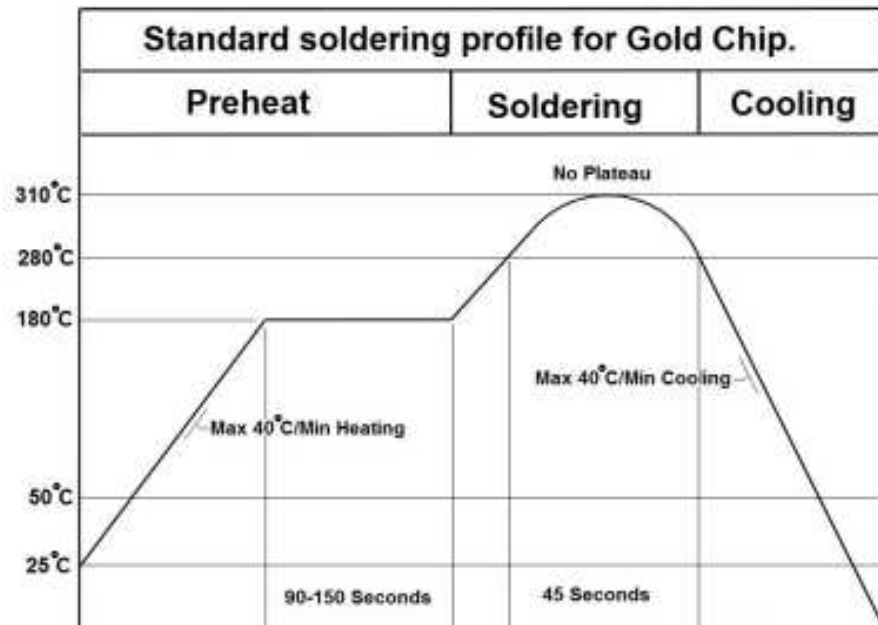

GOLD CHIP THERMISTOR GA10K3CG1311

Ordering information

Part Number	Description	Resistance @ +25°C	MOQ
GA10K3CG1311	Gold Chip Thermistor	10,000	484*

*For orders less than MOQ, contact Sales

[CLICK HERE >](#)

CONNECT WITH A SPECIALIST

NORTH AMERICA

Tel +1 800 522 6752

EUROPE

Tel +31 73 624 6999

ASIA

Tel +86 0400 820 6015

te.com/sensors

TE Connectivity, TE, TE Connectivity (logo) and Every Connection Counts are trademarks. All other logos, products and/or company names referred to herein might be trademarks of their respective owners

The information given herein, including drawings, illustrations and schematics which are intended for illustration purposes only, is believed to be reliable. However, TE Connectivity makes no warranties as to its accuracy or completeness and disclaims any liability in connection with its use. TE Connectivity's obligations shall only be as set forth in TE Connectivity's Standard Terms and Conditions of Sale for this product and in no case will TE Connectivity be liable for any incidental, indirect or consequential damages arising out of the sale, resale, use or misuse of the product. Users of TE Connectivity products should make their own evaluation to determine the suitability of each such product for the specific application.

© 2021 TE Connectivity Corporation. All Rights Reserved.

Version # 05/2021

