

## HV DRY PLUG-IN TRANSFORMER TERMINATIONS (PHVT-72)

UP TO 72 kV

### KEY FEATURES

- Dry interfaces, no oil-filling
- Insulator complies with EN 50299
- Pressure-tight resin housing
- Operates in SF6 and insulating liquids
- Pre-fabricated and factory-tested silicone-rubber stress cone
- Torque-controlled multi-contact conductor bolt
- Available with corona ring set up
- No special tools required to install the termination
- Insulated cable gland for sectionalization
- Type tested according to IEC 60840 and IEC 62067

TE Connectivity's (TE) Raychem high voltage dry plug-in transformer termination (PHVT) is designed for voltage up to 245 kV and installed in transformer cable entry housings. The PHVT is designed such that it is compatible with polymeric insulated cables independent of the manufacturer and can be adapted with respect to grounding required for various cable constructions. The complete system is separated into the epoxy insulator part and the plug-in part using the pre-moulded silicone stress cone.

The insulators are designed according to EN 50299. Hence, the PHVT is suitable for all transformers complying with the above standard. Each individual insulator is hermetically sealed and tested. Also, for entry housings with longer construction length individual adaptors are available. The epoxy insulator can be installed directly at the transformer manufacturer along with the corona ring to shield the termination, saving installation time on-site and reducing the risk of contamination of the cable entry housing.

The plug-in part consists of the pre-moulded silicone body for stress control and a mechanical cable lug for easy installation. The plug can be easily separated and re-installed for maintenance purpose. Accessories and add-on kits can be provided for testing and maintenance.

**Customers can count on consistent, high quality products, driven by TE's proven innovation and backed by our extraordinary customer support.**

# HV DRY PLUG-IN TRANSFORMER TERMINATIONS (PHVT-72)



MECHANICAL DATA	
Construction length (with IEC adapter)	310 (583) mm
Operating pressure SF6	0,35 - 0,85 MPa
Earth connection	6 x M12
Cantilever force	4.5 kN
Weight Approx. PHVT (Insulator) PHVX (Plug-in)	40 kg 40 kg
Packaging information PHVT (Insulator) PHVX (Plug-in)	700 x 390 x 650 mm 700 x 390 x 650 mm

NOTE : Weight and packaging information will vary for kits with adaptors or for larger sizes.

DESIGN DATA	
Diameter over prepared insulation	34 - 78 mm
Diameter over sheath	Up to 120 mm
Cross section (Cu / Al)	Up to 2000 mm <sup>2</sup>
Conductor connection	Mechanical (shear off bolts)
Material of housing	Epoxy resin
Material of connection bolt	Aluminium / Copper
Method of stress control	Geometric
Type of Stress cone	Pre-fabricated silicone rubber
Max. permissible dielectric stress	4 kV/mm (at insulation screen of cable)
Corona Shield	For use in insulation liquids an additional corona shield is necessary
Installation temperature	0°C to +40°C
Operation temperature	As per equipment
Storage temperature	0°C to +40°C

ELECTRICAL TYPE TEST IEC 60840	
Heating cycle voltage	72 kV
Partial discharge at ambient and elevated temperatures	54 kV
Lightning impulse voltage 1.2µs/50µs	325 kV
ELECTRICAL ROUTINE TEST IEC 60840	
AC withstand voltage	90 kV
Partial discharge test	54 kV

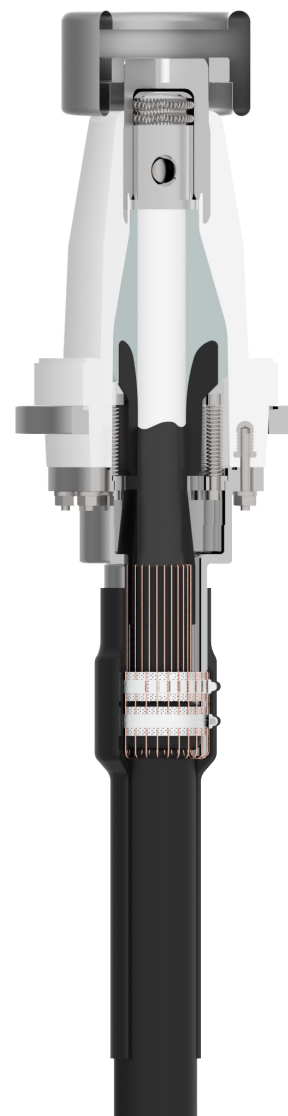

[te.com/energy](http://te.com/energy)

© 2018 TE Connectivity. All Rights Reserved. EPP-3170-DDS-10/18-Plug-in-Termination-PHVT-72

TE Connectivity and TE connectivity (logo) are trademarks. Other logos, product and/or company names might be trademarks of their respective owners. While TE has made every reasonable effort to ensure the accuracy of the information in this brochure, TE does not guarantee that it is error-free, nor does TE make any other representation, warranty or guarantee that the information is accurate, correct, reliable or current. TE reserves the right to make any adjustments to the information contained herein at any time without notice. TE expressly disclaims all implied warranties regarding the information contained herein, including, but not limited to, any implied warranties of merchantability or fitness for a particular purpose. The dimensions in this catalog are for reference purposes only and are subject to change without notice. Specifications are subject to change without notice. Consult TE for the latest dimensions and design specifications.

## FOR MORE INFORMATION: TE Technical Support Centers

USA:	+ 1 800 327 6996
Canada:	+ 1 (905) 475-6222
Mexico:	+ 52 (0) 55-1106-0800
Latin/S. America:	+ 54 (0) 11-4733-2200
France:	+ 33 380 583 200
UK:	+ 44 0870 870 7500
Germany:	+ 49 896 089 903
Spain:	+ 34 916 630 400
Italy:	+ 39 333 250 0915
Benelux:	+32 16 508 695
Russia:	+7 495-790 790 2-200
China:	+ 86 (0) 400-820-6015

While TE Connectivity (TE) has made every reasonable effort to ensure the accuracy of the information in the catalog, TE does not guarantee that it is error free, nor does TE make any other representation, warranty or implied warranties regarding the information contained herein, including, but not limited to, any implied warranties or merchantability or fitness for a particular purpose. The dimensions in this catalog are for reference purpose only and are subject to change without notice. Specifications are subject to change without notice. Consult TE for the latest dimensions and design specifications.

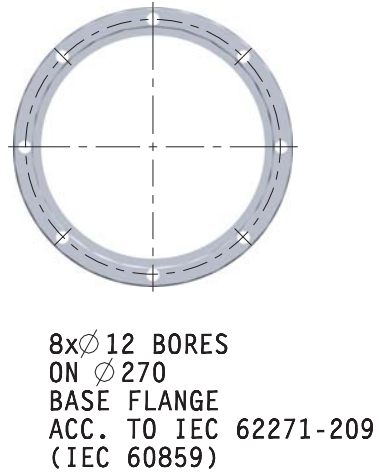
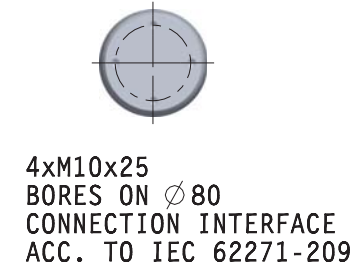
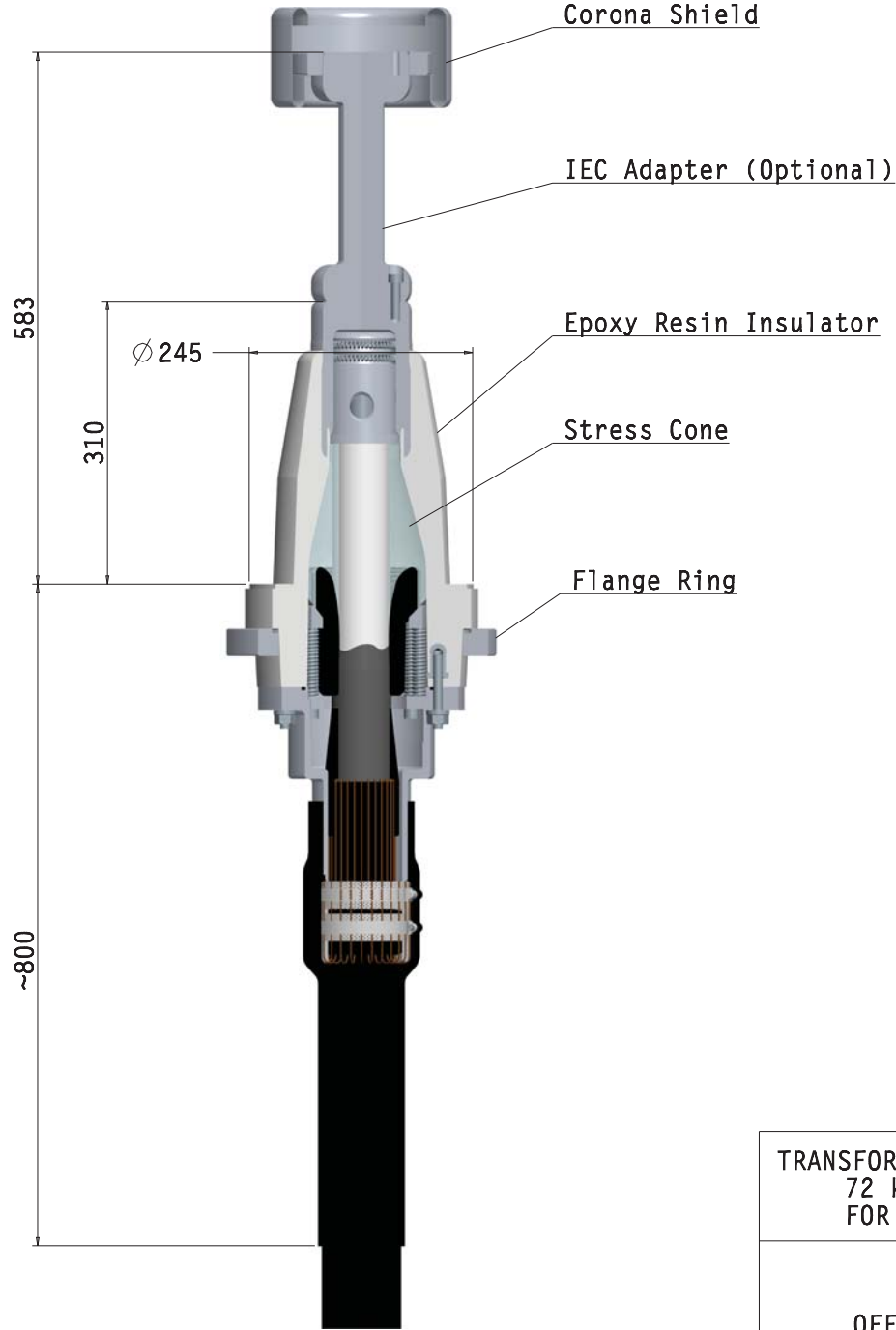
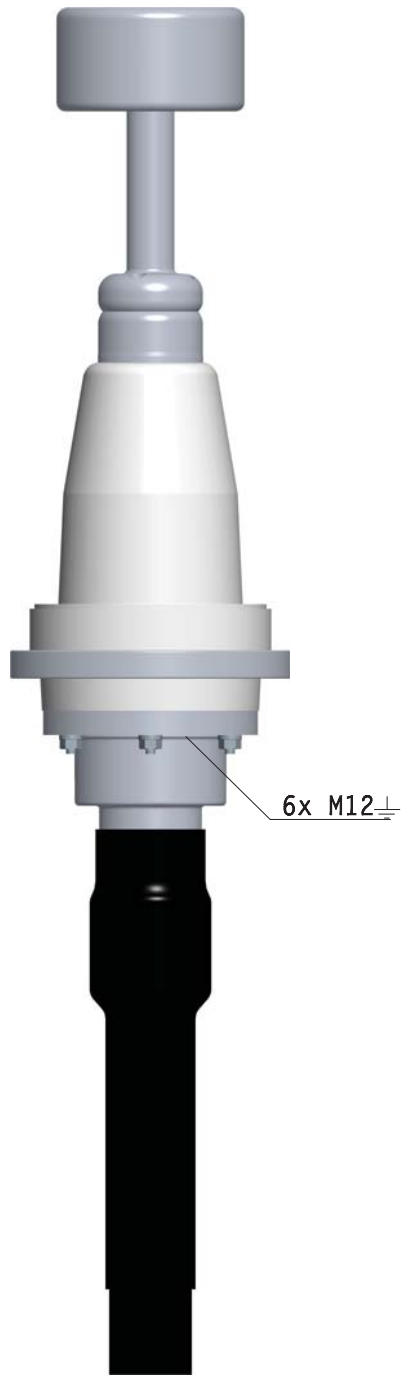

<p>TRANSFORMER TERMINATION 72 kV DRY TYPE FOR XLPE-CABLE</p>	 <p><b>Raychem High Voltage Cable Accessories</b></p> <p>TE Connectivity drawing no: EPD-204-1400-00 REV. 1</p>
<p>PHVT-72 OFFER DRAWING</p>	