

ITEM	QTY	DESCRIPTION
1	1	Threaded Pin M16
2	1	Assembly Main Body
3	1	HEL-750120-800A
4	1	Cable
5	1	Mastic
6	1	Stress Cone Adapter RSTI-SCA
7	1	Spring Wedge
8	1	Hexagon Nut ISO 4035 M16 A2
9	1	Back Plug 24kV
10	1	Covering Endcap
11	1	Clamping screw M6
12	1	Ground Lead
13	1	Washer DIN 9021 6.4 A2
14	1	Hexagon Nut ISO 4035-M6 A2
15	1	Washer DIN 125-8.4 A2

REVISIONS				
P.	LTM	DESCRIPTION	DATE	APVD
A		PRODUCTION RELEASE	25.JUL.2022	RK TOF

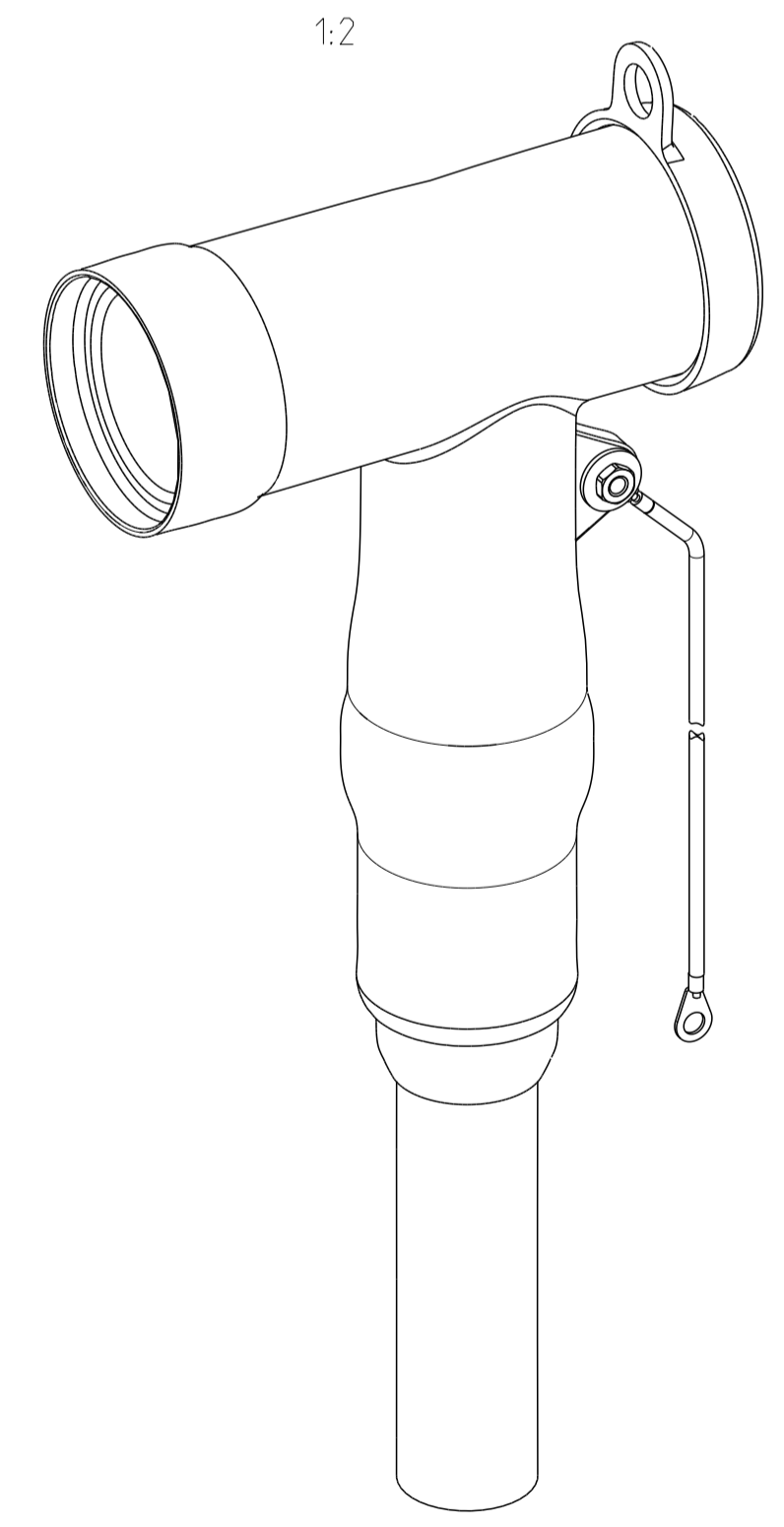
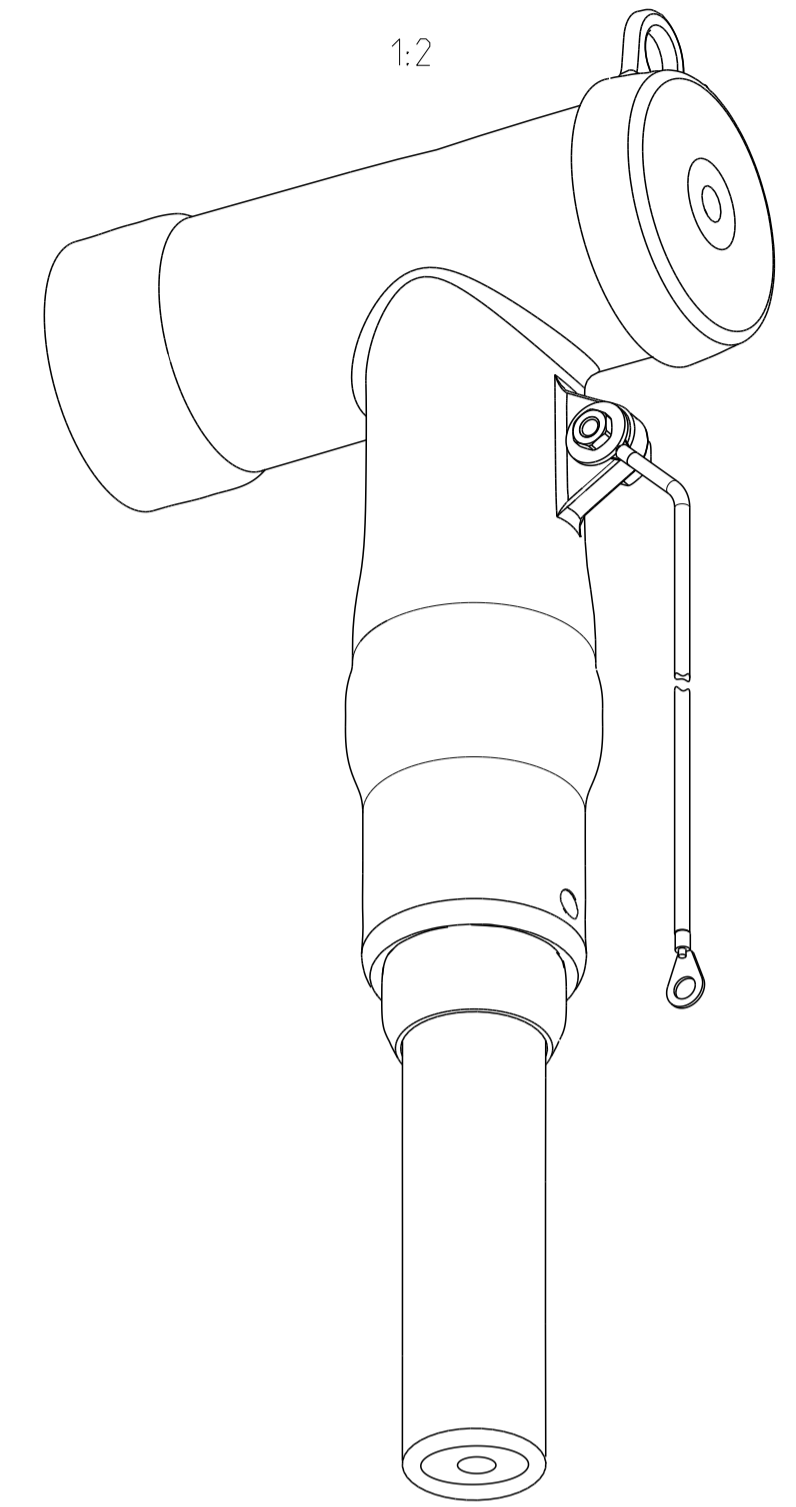

THIS DRAWING IS A CONTROLLED DOCUMENT.

DIMENSIONS:	TOLERANCES UNLESS OTHERWISE SPECIFIED:	DRN	12NOV2021	
mm	0 PLC # # # # # 1 PLC # # # # # 2 PLC # # # # # 3 PLC # # # # # 4 PLC # # # # # ANGLES # # # # #	CHK	12NOV2021	
MATERIAL	FINISH	APVD	12NOV2021	NAME
-	-	RSTI-5825		SIZE
-	-	A 00779		CAGE CODE
CUSTOMER DRAWING		DRAWING NO		DRAWING NO
		RSTI-5825		RESTRICTED TO
		SCALE 1:1		SHEET 1 OF 1
				REV A