

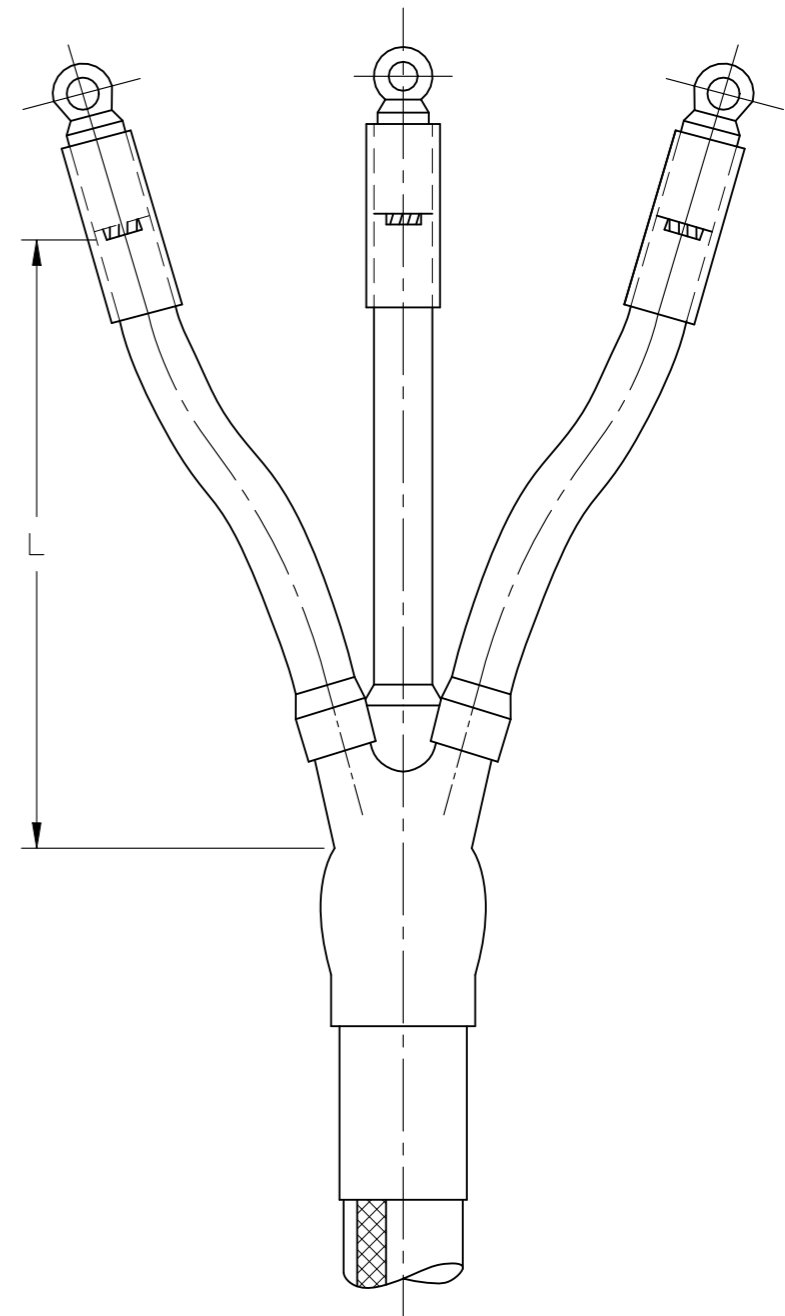

P	LTR	DESCRIPTION	DATE	DWN	APVD
	1	NEW DRAWING	18FEB2021	KR	AMO

NOTES:

- ONE TERMINATION KIT INCLUDES MATERIAL FOR 3 PHASES
- THE CORE LENGTHS CAN BE REDUCED TO THE REQUIREMENTS AT THE PLACE OF INSTALLATION, THE MINIMUM CORE LENGTH IS 450 MM
- FOR TERMINATIONS WITH MECHANICAL LUGS FOR M12 BOLTS, USE MODIFICATION CODE -L12
- FOR TERMINATIONS WITH MECHANICAL LUGS FOR M16 BOLTS, USE MODIFICATION CODE -L16 (AVAILABLE FOR CROSS SECTIONS 70-120 MM² AND 150-240 MM² ONLY)
- INSTALLED LENGTH MAY VARY DEPENDING ON CABLE DIMENSIONS AND CABLE CONNECTOR TYPE USED

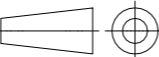

NOMINAL VOLTAGE U ₀ /U (kV)	CROSS SECTION (mm ²)	PART DESCRIPTION	DIMENSION L (mm)
3,5/6 and 06/10	25 - 50	GUST-12/ 25- 50/ 450	450
		GUST-12/ 25- 50/ 800	800
		GUST-12/ 25- 50/1200	1200
	70 - 120	GUST-12/ 70-120/ 450	450
		GUST-12/ 70-120/ 800	800
		GUST-12/ 70-120/1200	1200
	150 - 240	GUST-12/150-240/ 450	450
		GUST-12/150-240/ 800	800
		GUST-12/150-240/1200	1200

THIS DRAWING IS A CONTROLLED DOCUMENT.		DWN RAGHAVENDRA K. 18FEB2021	 TE Connectivity	
DIMENSIONS: mm		CHK A. MOTA 18FEB2021		
TOLERANCES UNLESS OTHERWISE SPECIFIED:		APVD T. ESCHERICH 18FEB2021	NAME MV H/S GUST TERMINATIONS	
		PRODUCT SPEC -	RESTRICTED TO -	
MATERIAL -		FINISH -	APPLICATION SPEC -	SIZE A3
		WEIGHT -	CAGE CODE 00779	DRAWING NO G-MV-H-S-GUST
CUSTOMER DRAWING			SCALE NTS	SHEET 1 OF 1
			REV 1	