

NOTES:

1 MARKED WITH TE PART NUMBER, CAGE CODE AND DATE CODE.

PART NUMBER EXAMPLE: D369 - H P 3 3 - N P 1 - 1 1 3 L

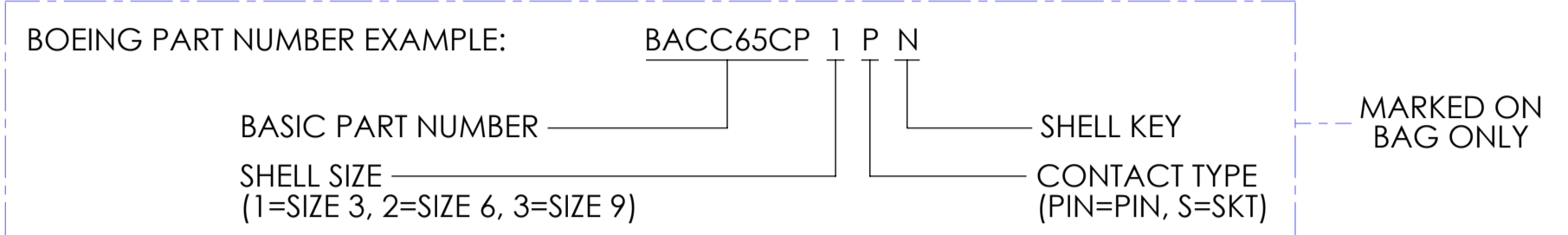
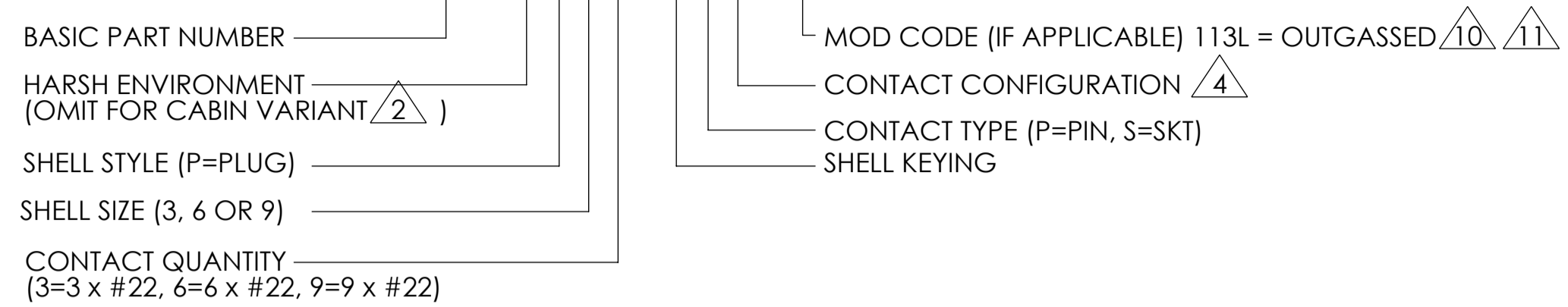

BOEING PART STANDARD BACC65CP REVISION 'B' REFERS. N.B. BACC65CP*** PART NUMBERS ARE SUPPLIED WITHOUT CONTACTS.

2 PERFORMANCE:

	'CABIN' CONNECTOR (INCLUDING OUTGASSED)	'HARSH ENVIRONMENT' CONNECTOR
	D369-P**-*-*** (-***)	D369-HP**-*-*** OR BACC65CP***
PERFORMANCE SPECIFICATION	108-160151	PENDING
TEMPERATURE RANGE	-55°C TO +175°C	
DIELECTRIC WITHSTAND VOLTAGE (AT SEA LEVEL)	1300VRMS <2mA LEAKAGE	
DURABILITY	500 MATING CYCLES MIN.	
INSULATION RESISTANCE	≥5000 MΩ INITIAL	
IP RATING	IP67	
SEALING	RTCA DO160 - CATEGORY A4 (15,000ft)	EN2591-314: 12.1kPa (1.75psi) @ 15km (50,000ft)
HUMIDITY	RTCA DO160 - CATEGORY A	EN2591-321 / EIA-364-31 METHOD IV

3. INSERTION / EXTRACTION TOOL (M81969/14-01 OR EQUIVALENT) SUPPLIED SEPARATELY.

4 CONTACT CONFIGURATION:

CONFIG.	CONTACT DESCRIPTION	CONTACT P/N (OR EQUIVALENT)		CRIMP POSITIONER		CRIMP TOOL	WIRE ACCOMODATION	CURRENT RATING
		PIN	SOCKET	PIN	SOCKET			
0		NO CONTACTS SUPPLIED						
1	CRIMP, COPPER WIRE	38941-22L	38946-22L	M22520/2-09	M22520/2-06	M22520/2-01	22-28 AWG	5A (22 AWG)
2	CRIMP, ALUMINIUM WIRE	200-1042-22	200-1142-22	KAL2		ALNP 22-A	22 AWG	5A
3	CRIMP, ENLARGED COPPER WIRE	182-0860-22	182-0862-22	M22520/2-09	M22520/2-06	M22520/2-01	20-24 AWG	5A (20 AWG)

5. MATERIALS:

COMPONENT	MATERIAL (FINISH: CLEAN IN ALL CASES)
SEALS	SILICONE / FLUOROSILICONE BLEND RUBBER
BODY / INSERT COMPONENTS	THERMOPLASTIC

6. IF FILLER PLUGS ARE REQUIRED, USE THE FOLLOWING:
TE PART NUMBER - 600300-22.
MIL-SPEC PART NUMBER - M527488-22-2.

7. MAXIMUM WEIGHTS (WITHOUT CONTACTS):
3 WAY - 1.9g (PIN INSERT), 2.0g (SOCKET INSERT).
6 WAY - 2.4g (PIN INSERT), 2.6g (SOCKET INSERT).
9 WAY - 3.0g (PIN INSERT), 3.2g (SOCKET INSERT).

8 FOR ALL 'HARSH ENVIRONMENT' VARIANTS, THE REAR BODY IS TO BE COLOURED DARK BLUE.

9 DIMENSIONS ARE TRUE POSITIONS OF CAVITIES AT FRONT OF PIN INSERT (SOCKET OPPOSITE). CENTRE OF EACH CAVITY ± 0.20 A B.

SHELL KEYING (ALL SIZES)

ORIENTATION	COLOUR	POSITIONS (±0.03)	
		D1	D2
N	BLACK	-2.35	2.90
A	DARK RED	-2.35	-2.90
B	DARK BLUE	-1.175	-2.90
C	DARK GREEN	0	-2.90
D	YELLOW	1.175	-2.90

10 FOR OUTGASSED (113L) VARIANTS, ASSEMBLIES TO BE OUTGASSED PER GUIDANCE IN ASTM 595: VACUUM BAKED FOR 24 HOURS @ <1.33x10⁻⁴Pa, 125°C

11 OUTGASSING (113L MOD) IS ONLY AVAILABLE/ ONLY APPLIES TO CABIN ENVIRONMENT PART NUMBERS.

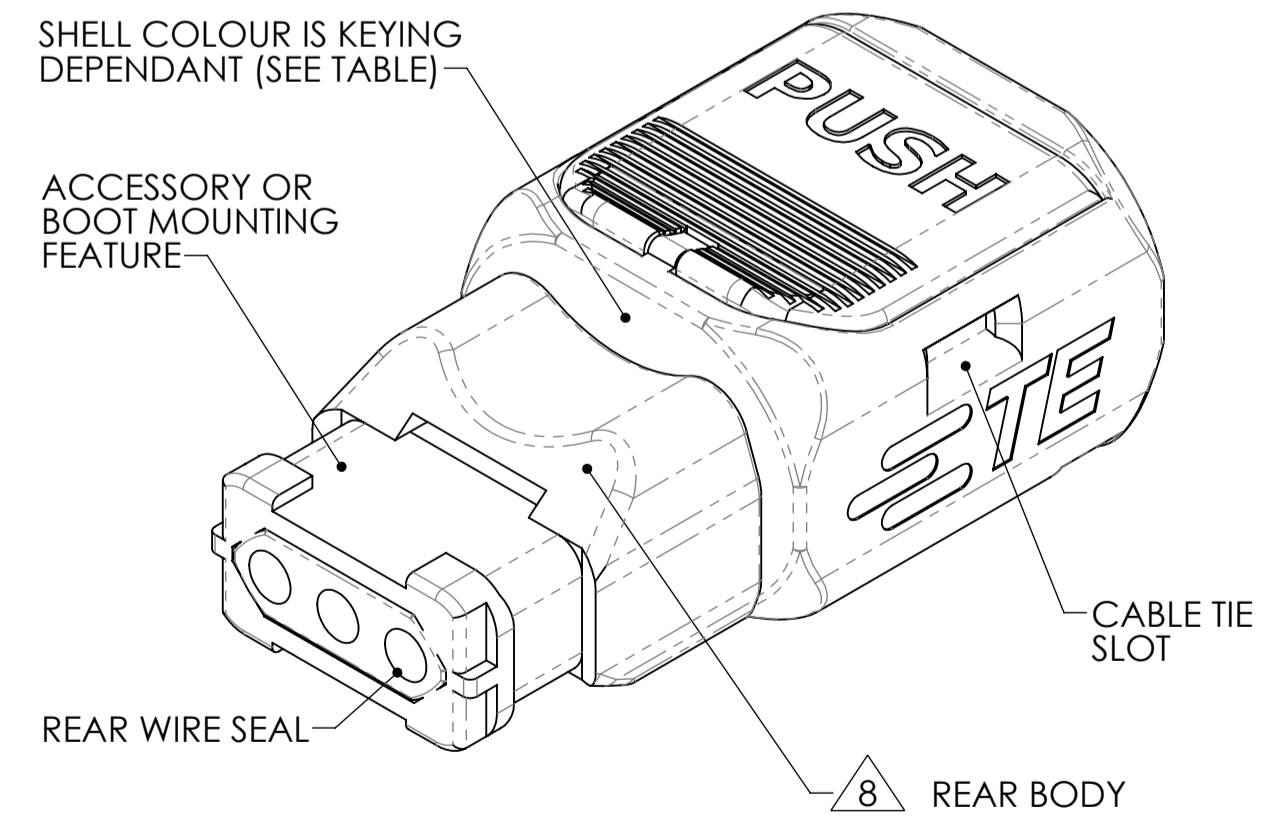

3 WAY CONNECTOR

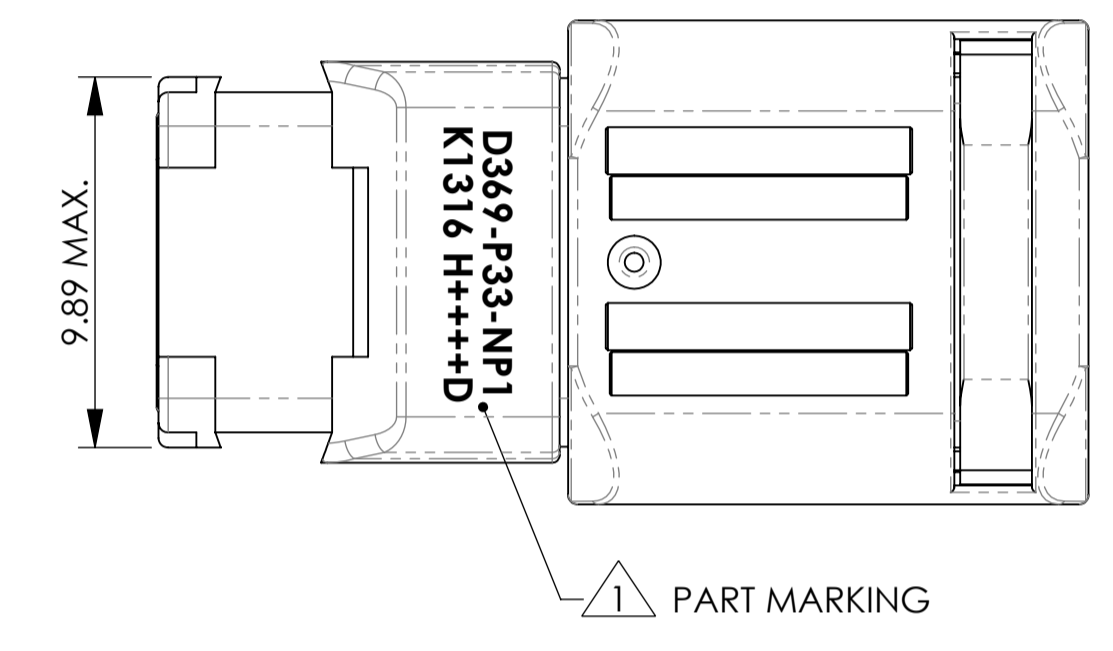
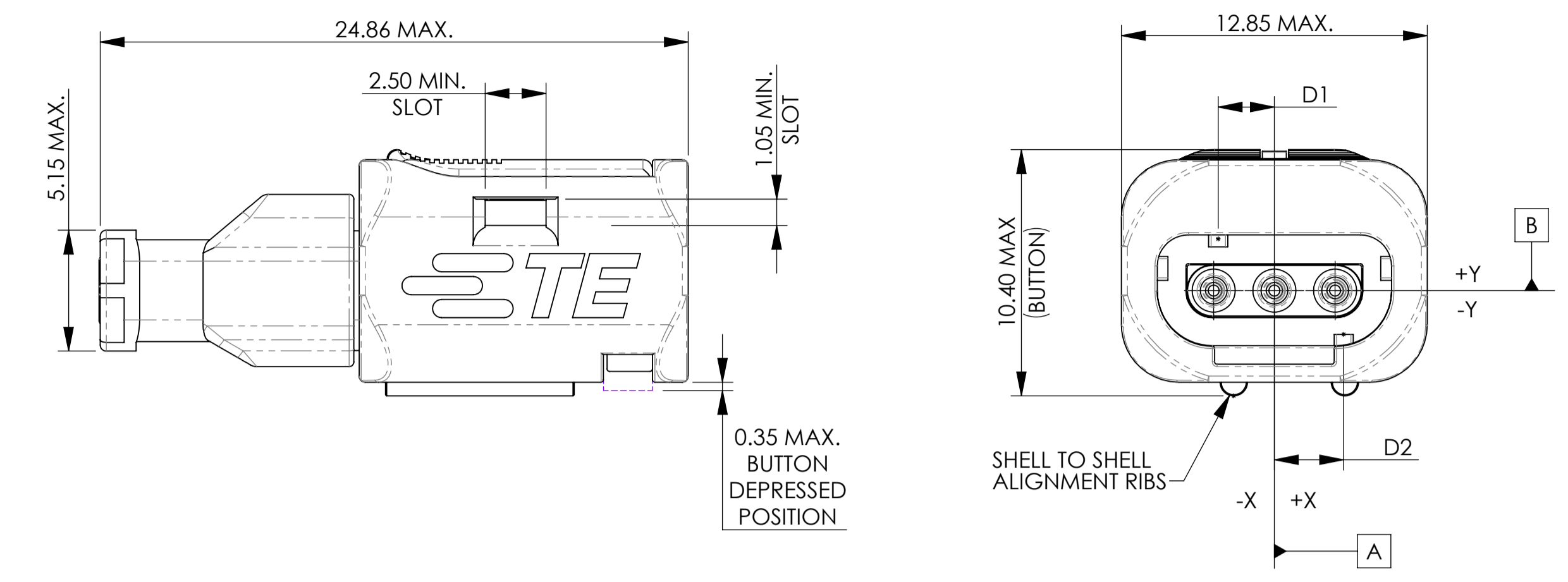

COORDINATE POSITIONS OF CONTACTS (3 WAY CONNECTOR ONLY)

CONTACT POSITION (ID)	CONTACT LOCATION	
	X AXIS (mm)	Y AXIS (mm)
1	-2.54	0
2	0	0
3	2.54	0

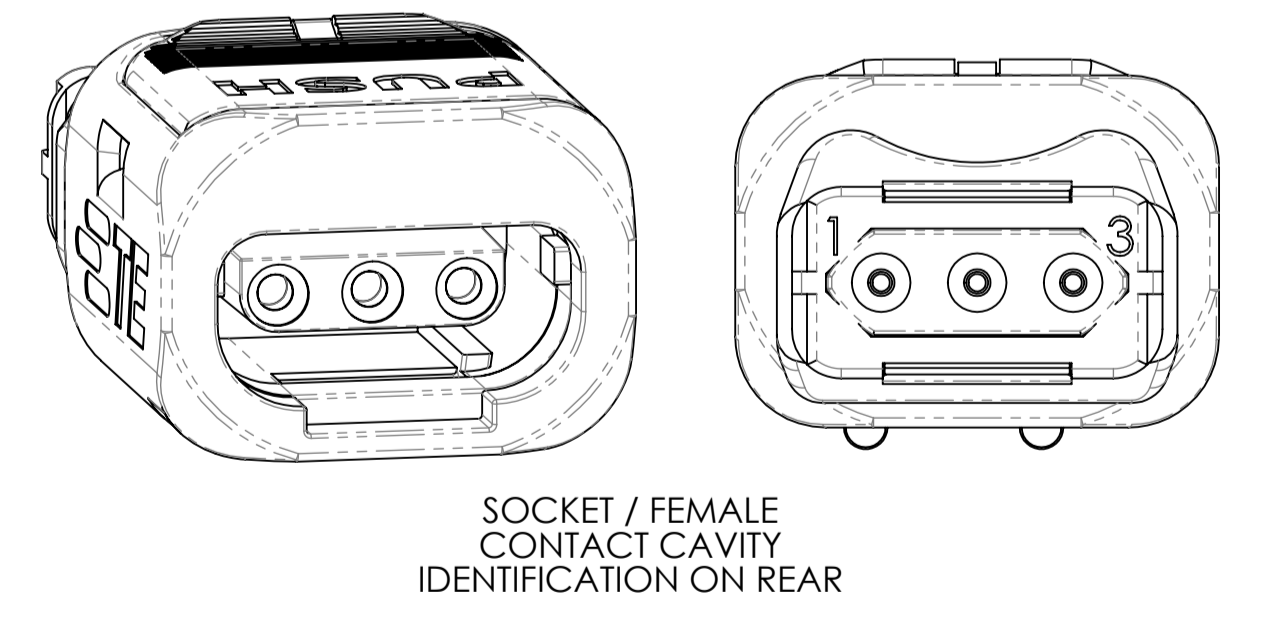
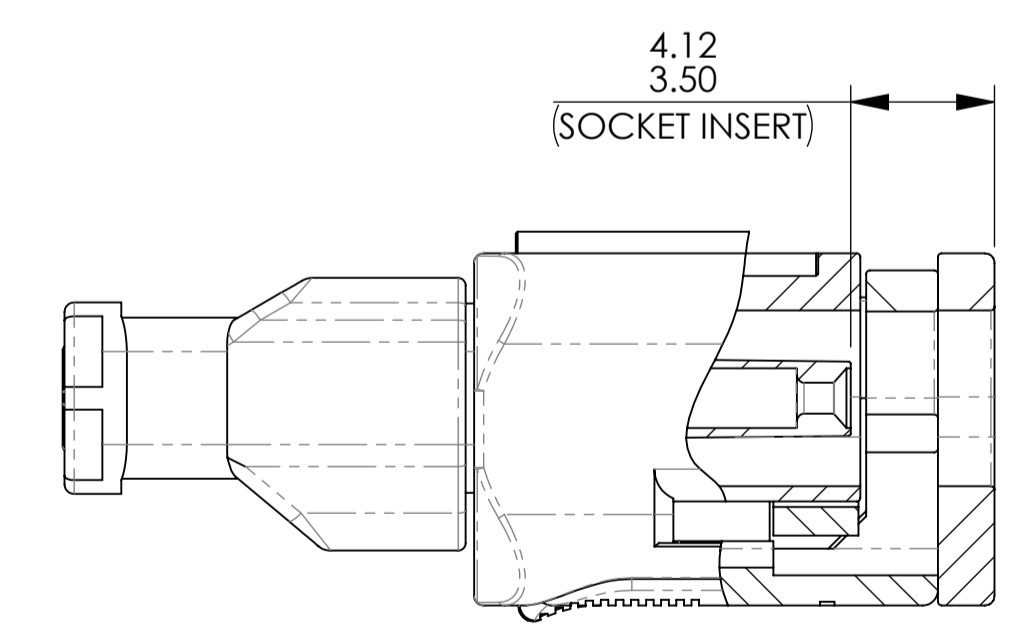
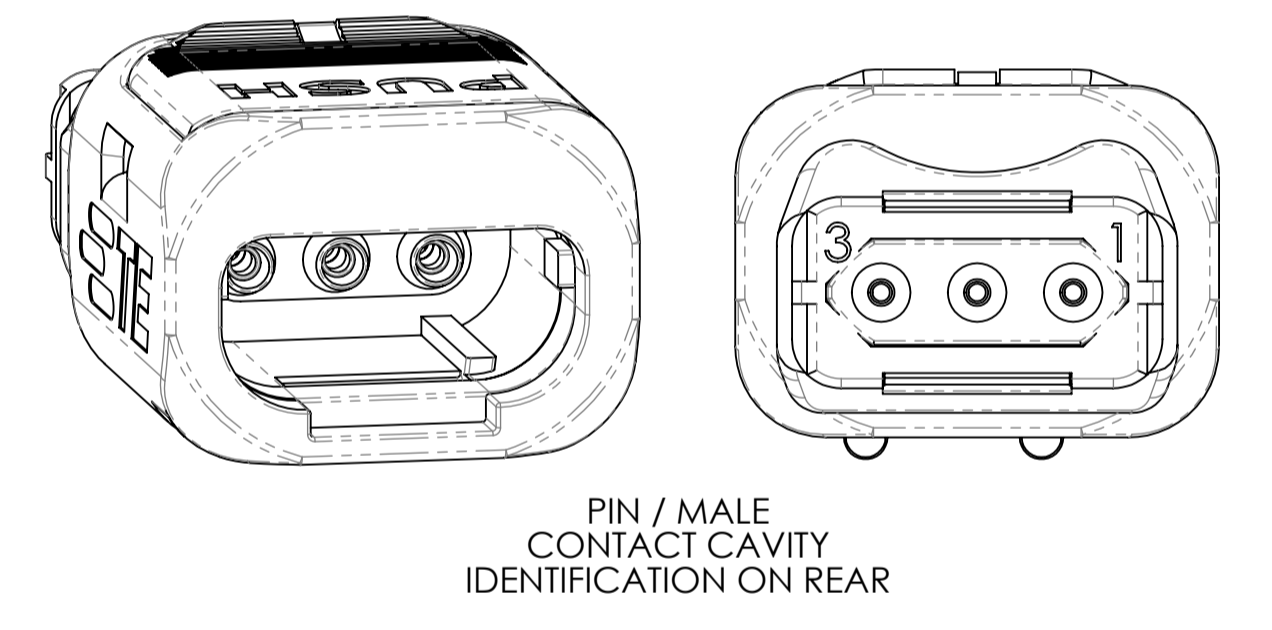
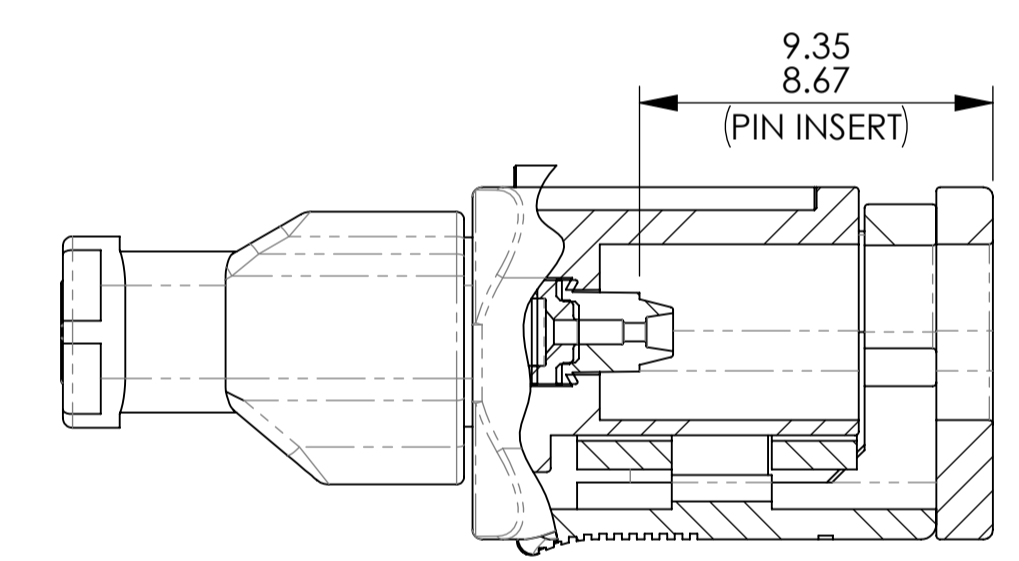

IF IN DOUBT, ASK

BS8888 THIRD ANGLE PROJECTION	MATERIAL: SEE NOTES	FINISH:	 DEUTSCH TE CONNECTIVITY UK LTD., ST. LEONARDS-ON-SEA, TN38 9RF, UK
UNLESS OTHERWISE STATED: DIMENSIONS: mm [INCHES]	TITLE: 369 PLUG CONNECTOR, ENVELOPE DRAWING	TYPE: CUSTOMER DRAWING	
IF IN DOUBT, ASK	SIZE: A1	SCALE: 5:1	DRAWING NUMBER: 612827-ENV
			SHEET: 1 OF 2
			ISSUE: AA

9 WAY CONNECTOR

6 WAY CONNECTOR

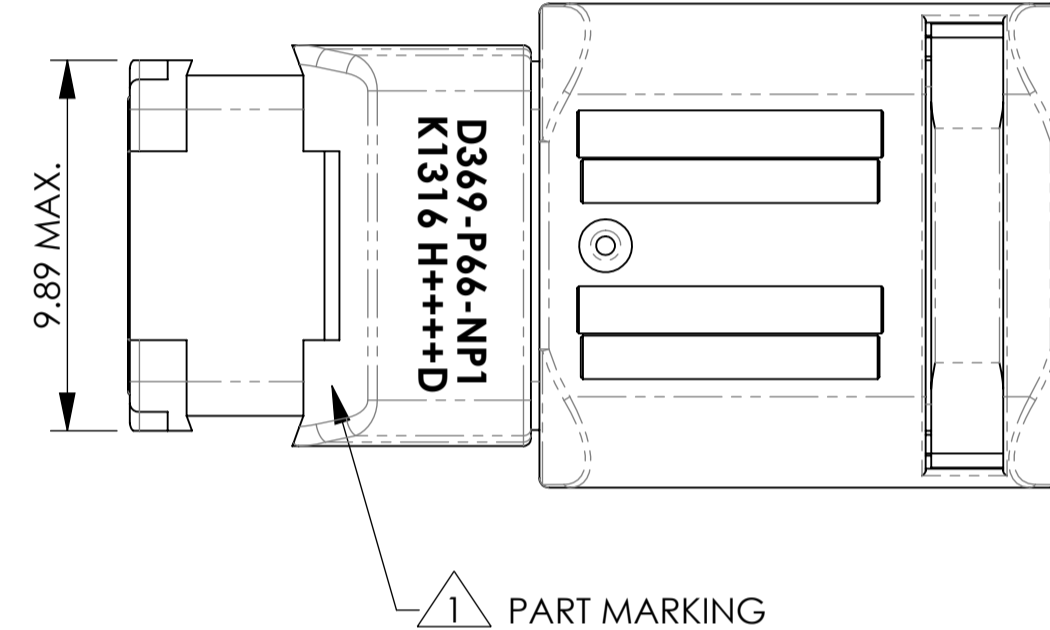
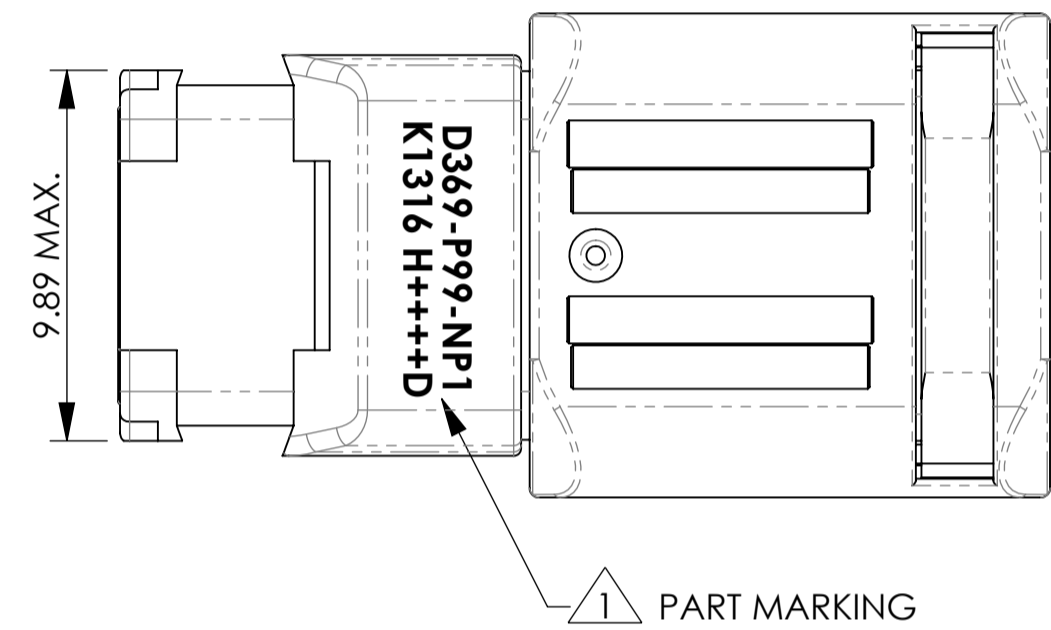
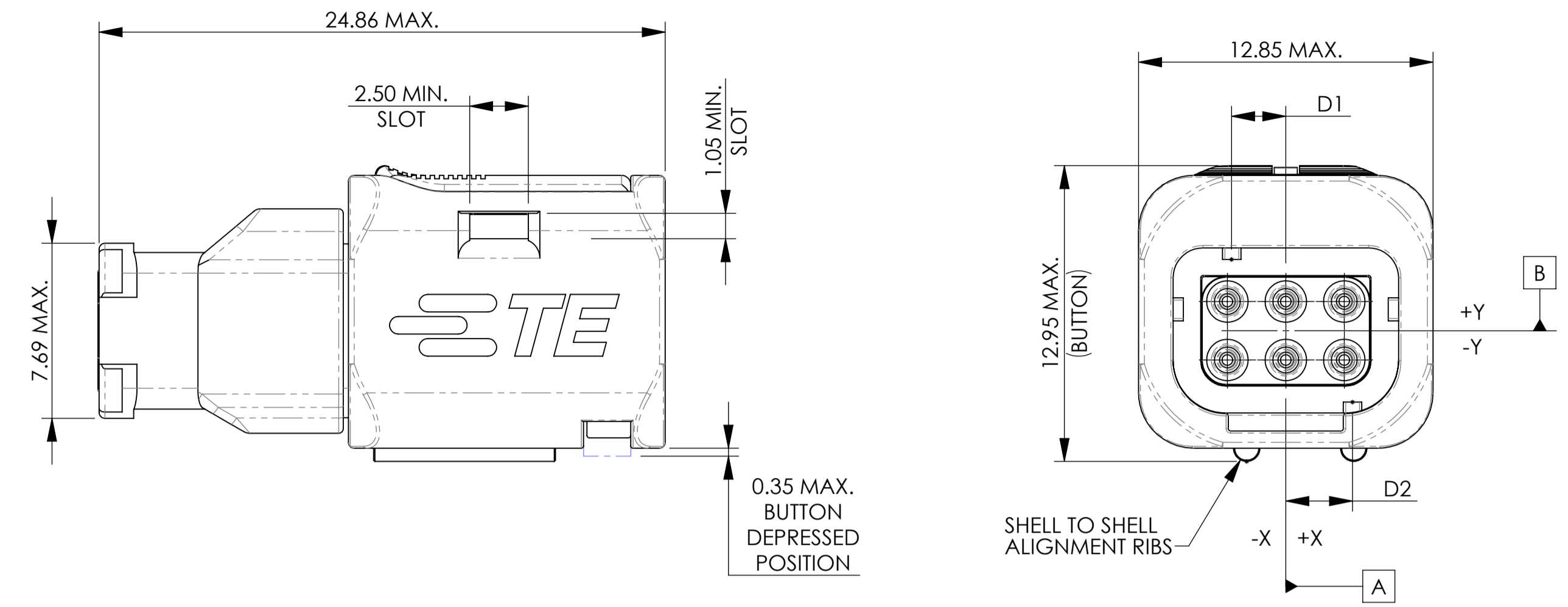
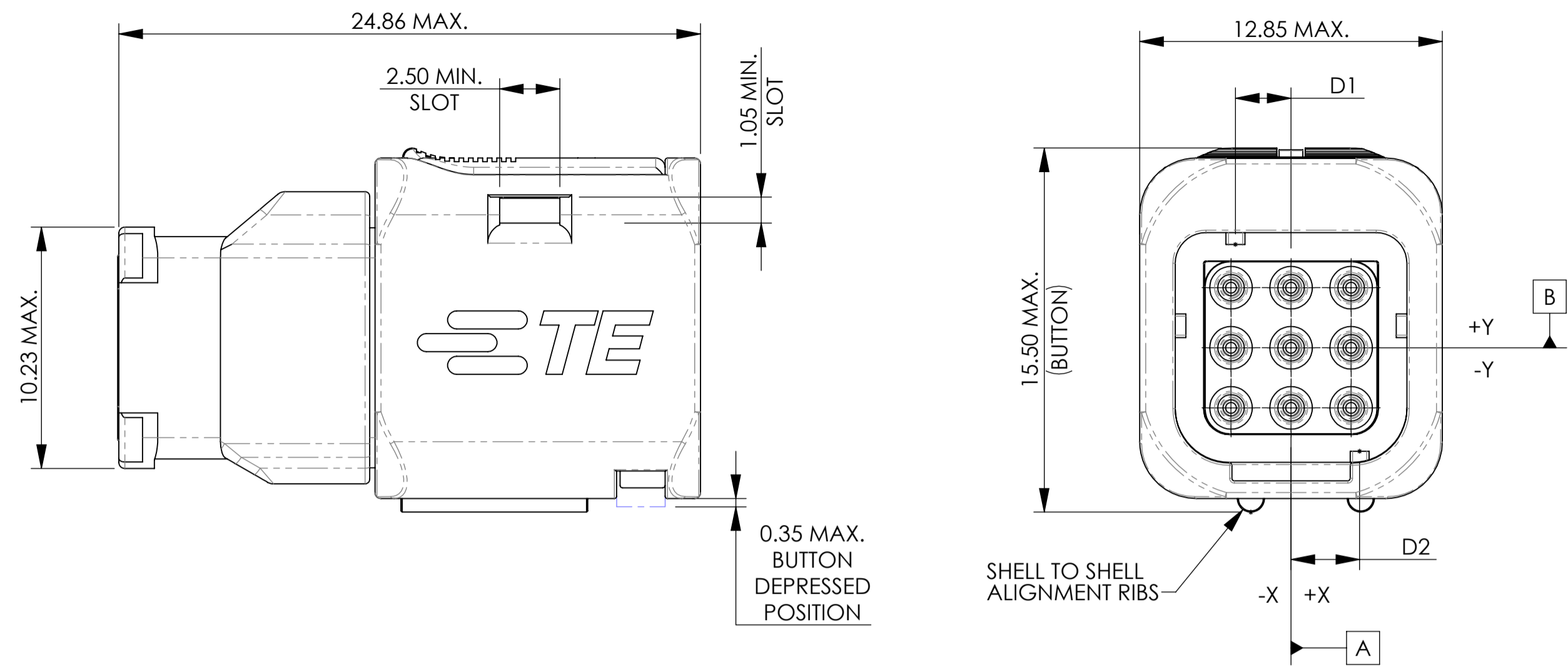

COORDINATE POSITIONS OF CONTACTS (9 WAY CONNECTOR ONLY)

CONTACT POSITION (ID)	CONTACT LOCATION	
	X AXIS (mm)	Y AXIS (mm)
1	-2.54	2.54
2	0	2.54
3	2.54	2.54
4	2.54	0
5	0	0
6	-2.54	0
7	-2.54	-2.54
8	0	-2.54
9	2.54	-2.54

COORDINATE POSITIONS OF CONTACTS (6 WAY CONNECTOR ONLY)

CONTACT POSITION (ID)	CONTACT LOCATION	
	X AXIS (mm)	Y AXIS (mm)
1	-2.54	1.27
2	0	1.27
3	2.54	1.27
4	2.54	-1.27
5	0	-1.27
6	-2.54	-1.27

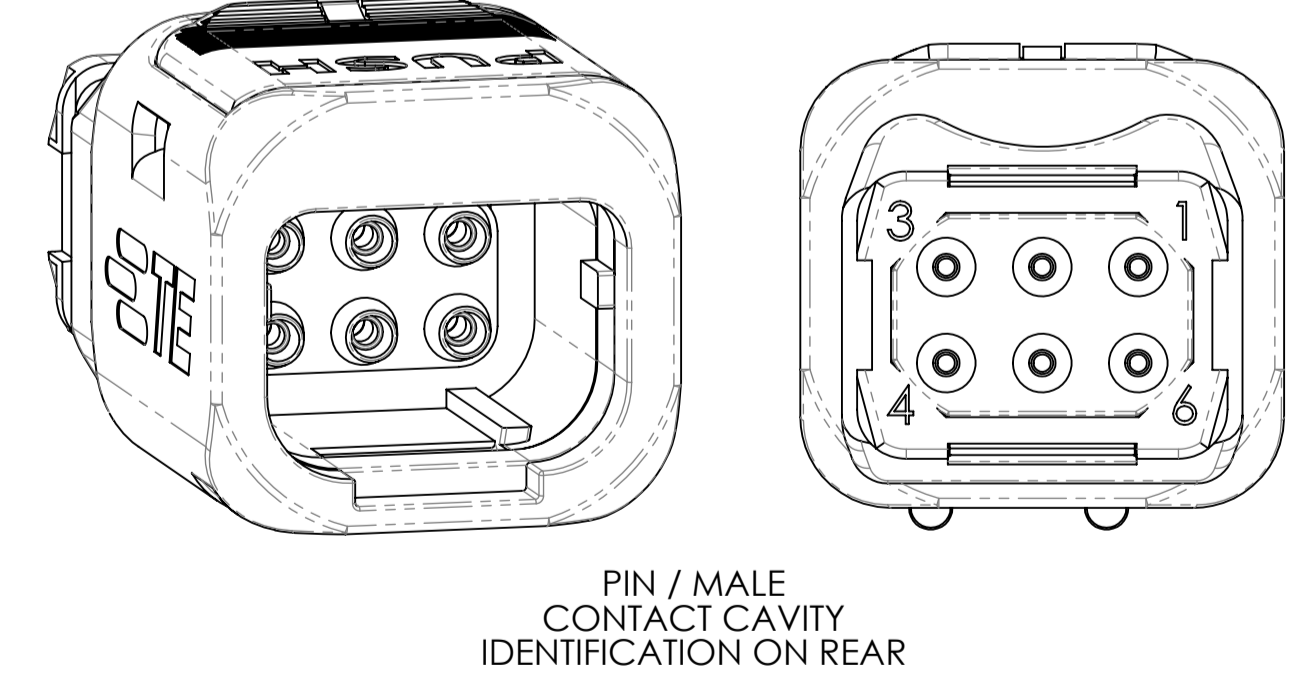
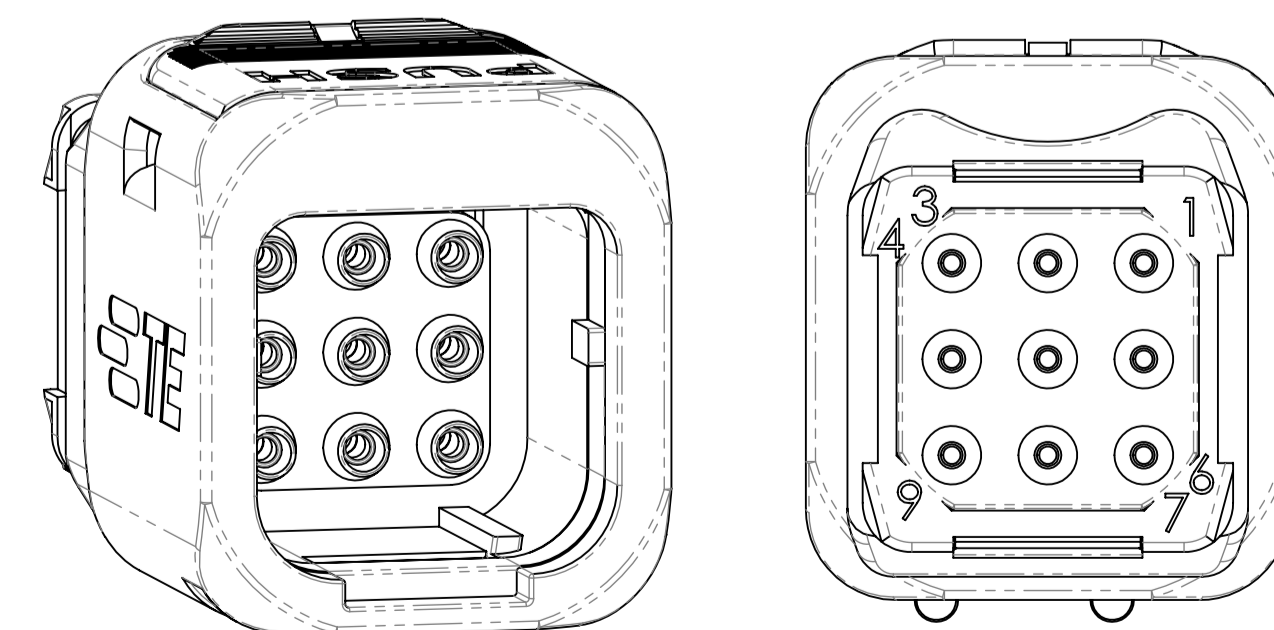
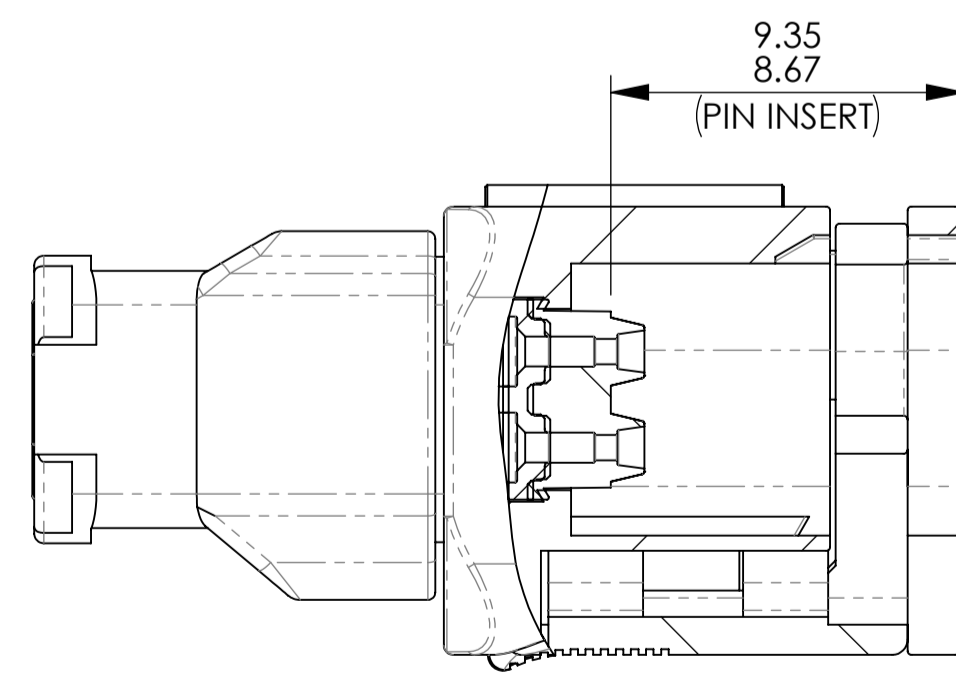
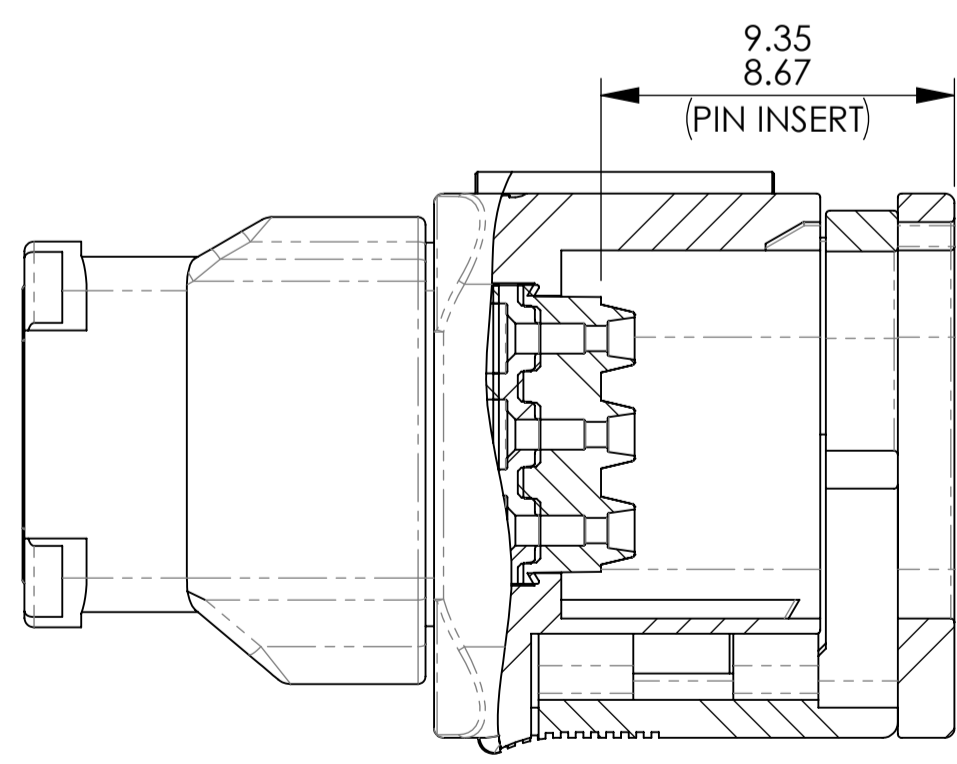
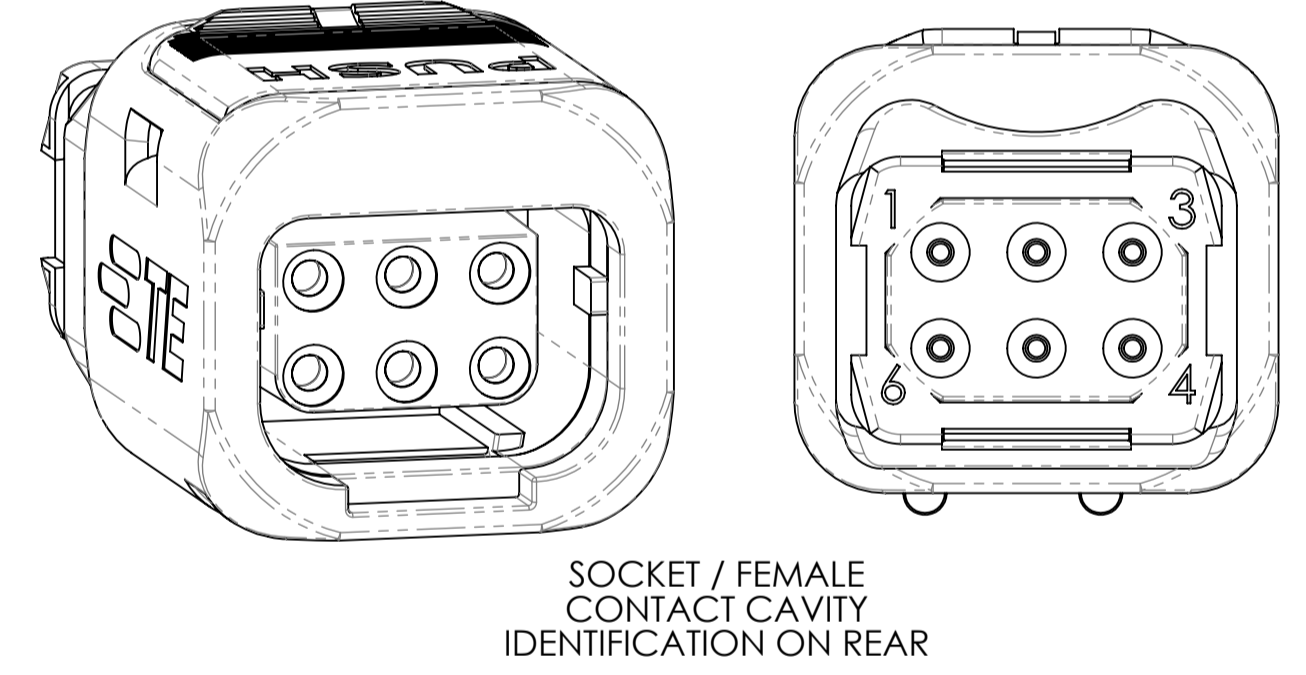
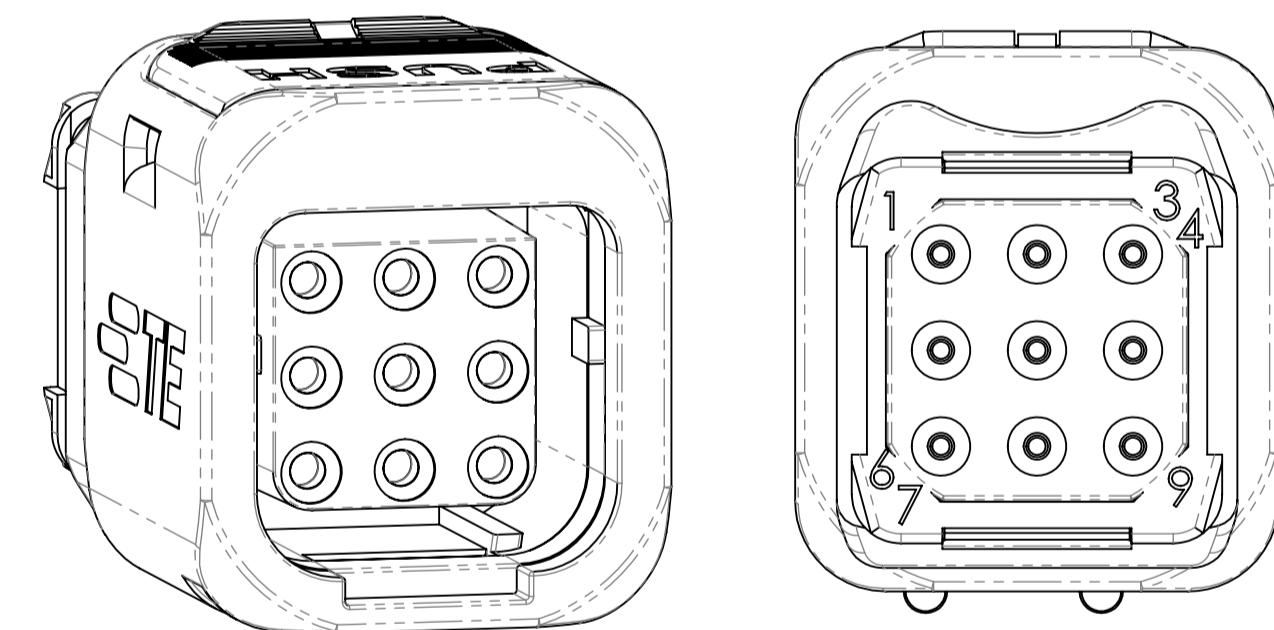
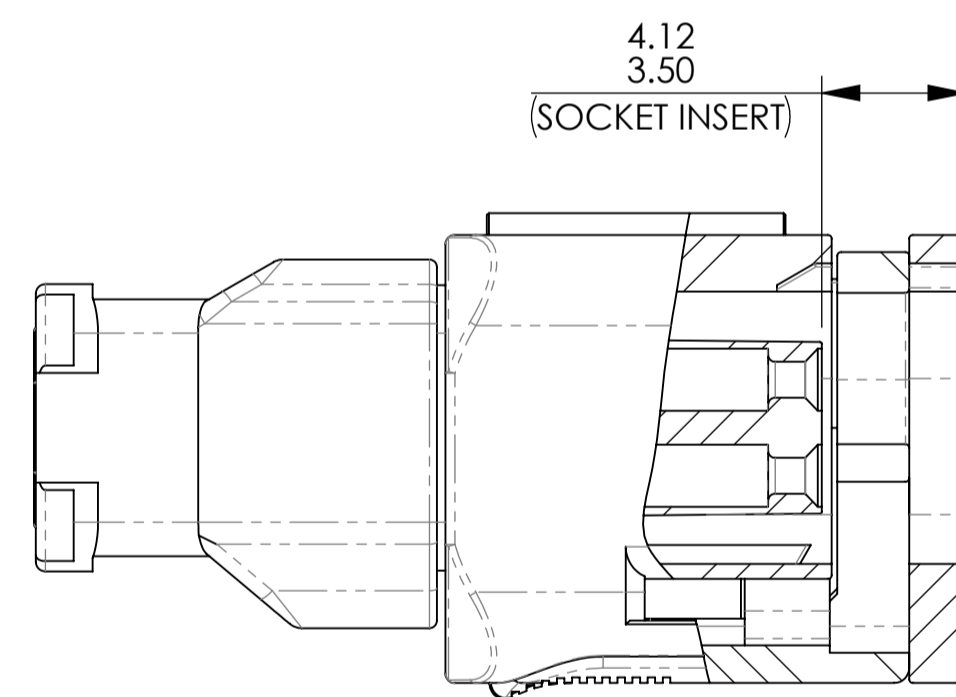
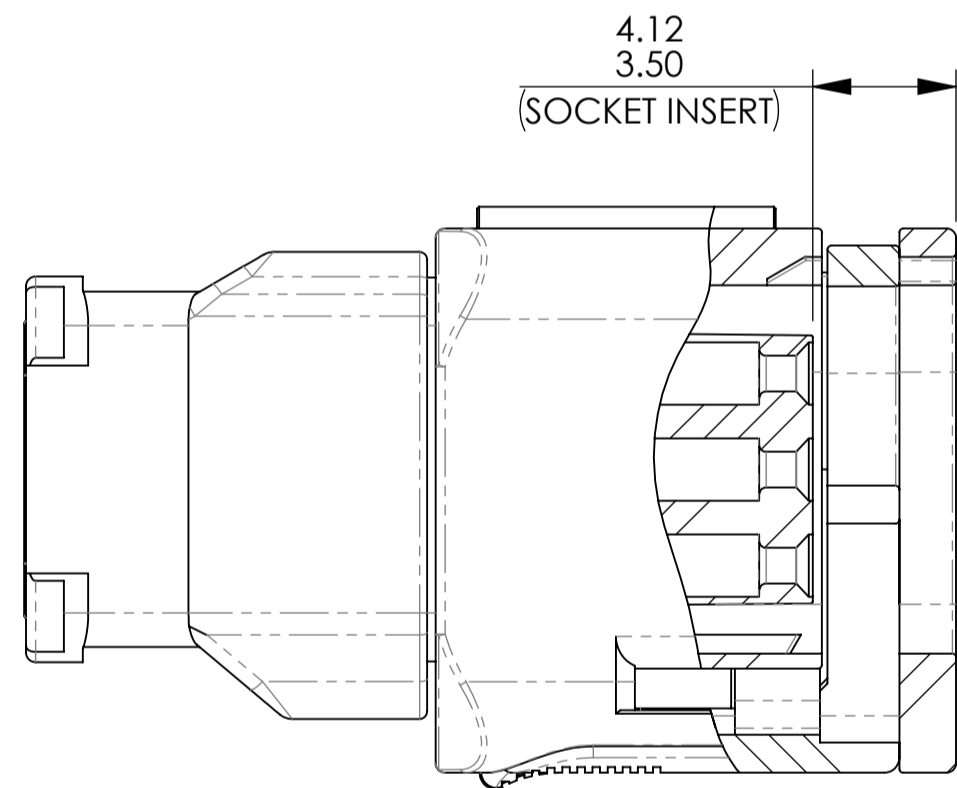

PIN / MALE CONTACT CAVITY IDENTIFICATION ON REAR

PIN / MALE CONTACT CAVITY IDENTIFICATION ON REAR

BS8888 THIRD ANGLE PROJECTION	MATERIAL: SEE NOTES	FINISH:	 DEUTSCH
UNLESS OTHERWISE STATED: DIMENSIONS: mm [INCHES]	TITLE: 369 PLUG CONNECTOR, ENVELOPE DRAWING	TYPE: CUSTOMER DRAWING	
IF IN DOUBT, ASK	SIZE: A1	SCALE: 5:1	DRAWING NUMBER: 612827-ENV
			SHEET: 2 OF 2
			ISSUE: AA

THIS INFORMATION IS CONFIDENTIAL AND PROPRIETARY TO TYCO ELECTRONICS CORPORATION AND ITS WORLDWIDE SUBSIDIARIES AND AFFILIATES (TE). IT MAY NOT BE DISCLOSED TO ANYONE, OTHER THAN TE PERSONNEL, WITHOUT AUTHORIZATION FROM TE (www.teconnectivity.com).