

NOTES:

1 MARKED WITH TE PART NUMBER, CAGE CODE AND DATE CODE.

PART NUMBER EXAMPLE: D369 - H P 3 3 - N P 1

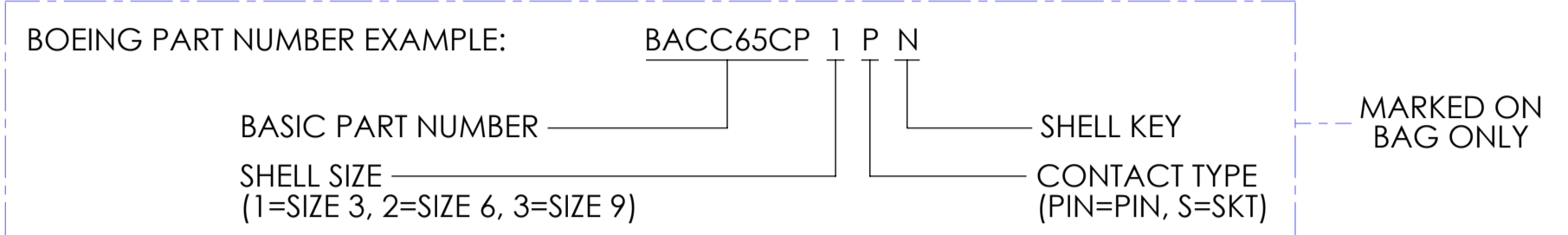
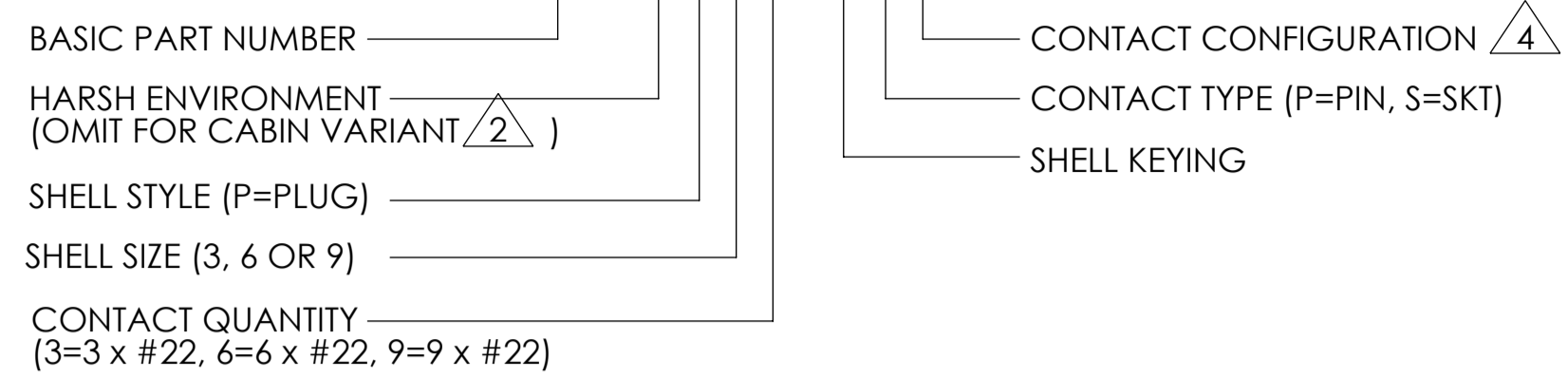

BOEING PART STANDARD BACC65CP REVISION 'B' REFERS. N.B. BACC65CP*** PART NUMBERS ARE SUPPLIED WITHOUT CONTACTS.

2 PERFORMANCE:

	'CABIN' CONNECTOR D369-P***	'HARSH ENVIRONMENT' CONNECTOR D369-HP*** OR BACC65CP***
TEMPERATURE RANGE	-55°C TO +175°C	
DIELECTRIC WITHSTAND VOLTAGE (AT SEA LEVEL)	1500VRMS <2mA LEAKAGE	
DURABILITY	500 MATING CYCLES MIN.	
INSULATION RESISTANCE	≥5000 MΩ INITIAL	
IP RATING	IP65	IP67
SEALING	RTCA DO160 - CATEGORY A4 (15,000ft)	EN2591-314: 12.1kPa (1.75psi) @ 15km (50,000ft)
HUMIDITY	RTCA DO160 - CATEGORY A	EN2591-321 / EIA-364-31 METHOD IV

3. INSERTION / EXTRACTION TOOL (M81969/14-01 OR EQUIVALENT) SUPPLIED SEPARATELY.

4 CONTACT CONFIGURATION:

CONFIG.	CONTACT DESCRIPTION	CONTACT P/N (OR EQUIVALENT)		CRIMP POSITIONER		CRIMP TOOL	WIRE ACCOMODATION	CURRENT RATING
		PIN	SOCKET	PIN	SOCKET			
0		NO CONTACTS SUPPLIED						
1	CRIMP, COPPER WIRE	38941-22L	38946-22L	M22520/2-09	M22520/2-06	M22520/2-01	22-28 AWG	5A (22 AWG)
2	CRIMP, ALUMINIUM WIRE	200-1042-22	200-1142-22	KAL2		ALNP 22-A	22 AWG	5A
3	CRIMP, ENLARGED COPPER WIRE	182-0860-22	182-0862-22	M22520/2-09	M22520/2-06	M22520/2-01	20-24 AWG	5A (20 AWG)

5. MATERIALS:

COMPONENT	MATERIAL (FINISH: CLEAN IN ALL CASES)
SEALS	SILICONE / FLUOROSILICONE BLEND RUBBER
BODY / INSERT COMPONENTS	THERMOPLASTIC

6. IF FILLER PLUGS ARE REQUIRED, USE THE FOLLOWING:
TE PART NUMBER - 600300-22.
MIL-SPEC PART NUMBER - MS27488-22-2.

7. MAXIMUM WEIGHTS (WITHOUT CONTACTS):
3 WAY - 1.9g (PIN INSERT), 2.0g (SOCKET INSERT).
6 WAY - 2.4g (PIN INSERT), 2.6g (SOCKET INSERT).
9 WAY - 3.0g (PIN INSERT), 3.2g (SOCKET INSERT).

8 FOR ALL 'HARSH ENVIRONMENT' VARIANTS, THE REAR BODY IS TO BE COLOURED DARK BLUE.

9 DIMENSIONS ARE TRUE POSITIONS OF CAVITIES AT FRONT OF PIN INSERT (SOCKET OPPOSITE). CENTRE OF EACH CAVITY ± 0.20 A B.

SHELL KEYING (ALL SIZES)			
ORIENTATION	COLOUR	POSITIONS (±0.03)	
		D1	D2
N	BLACK	-2.35	2.90
A	DARK RED	-2.35	-2.90
B	DARK BLUE	-1.175	-2.90
C	DARK GREEN	0	-2.90
D	YELLOW	1.175	-2.90

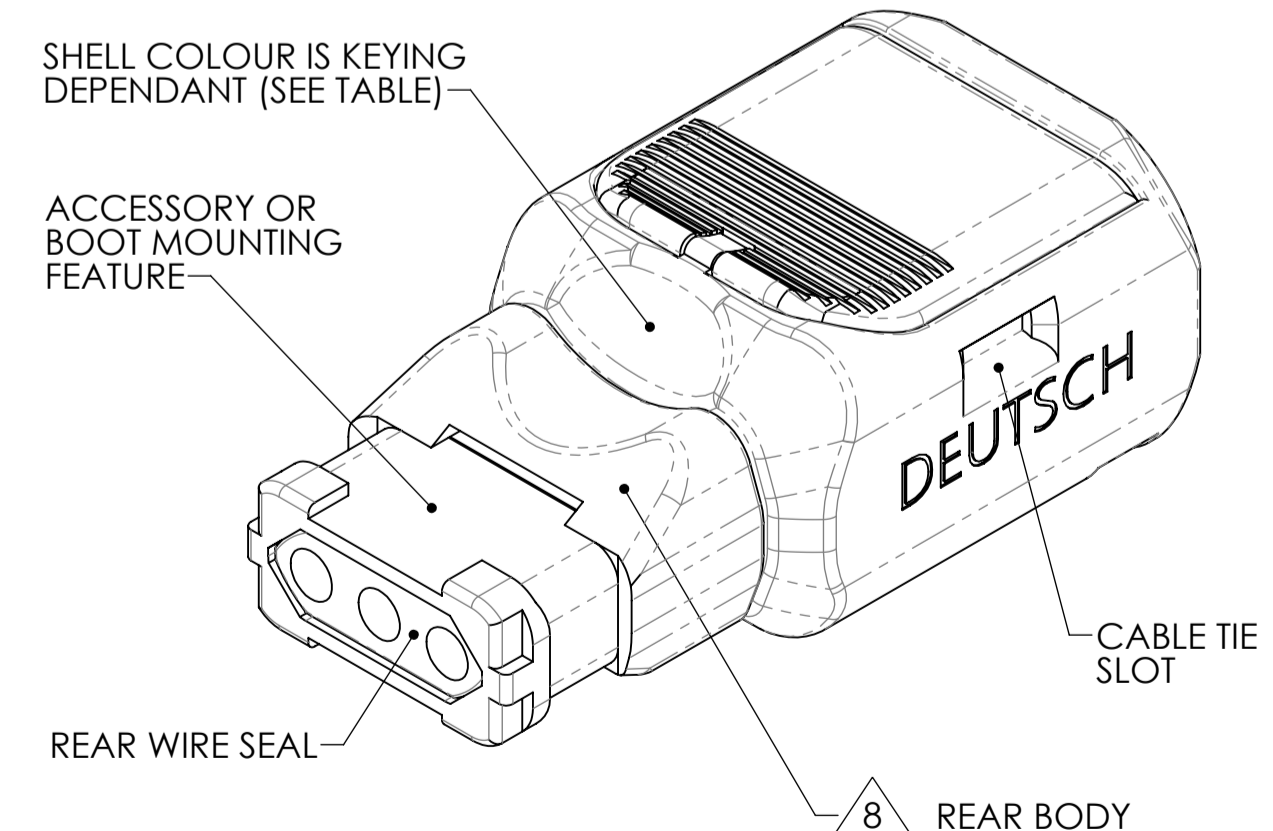

3 WAY CONNECTOR

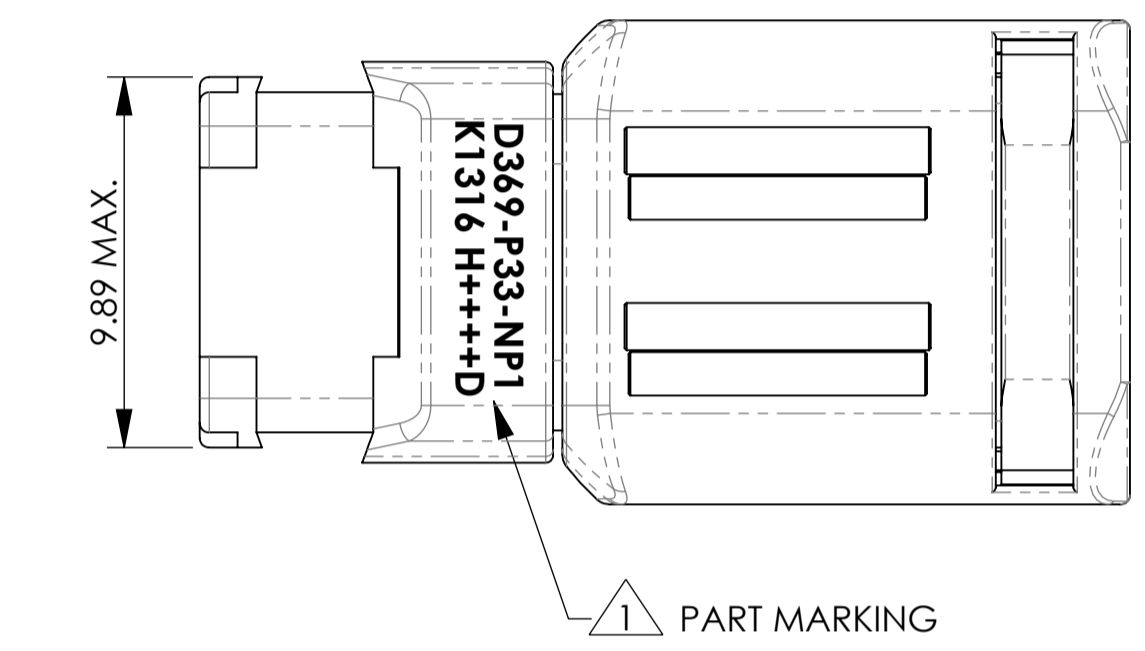
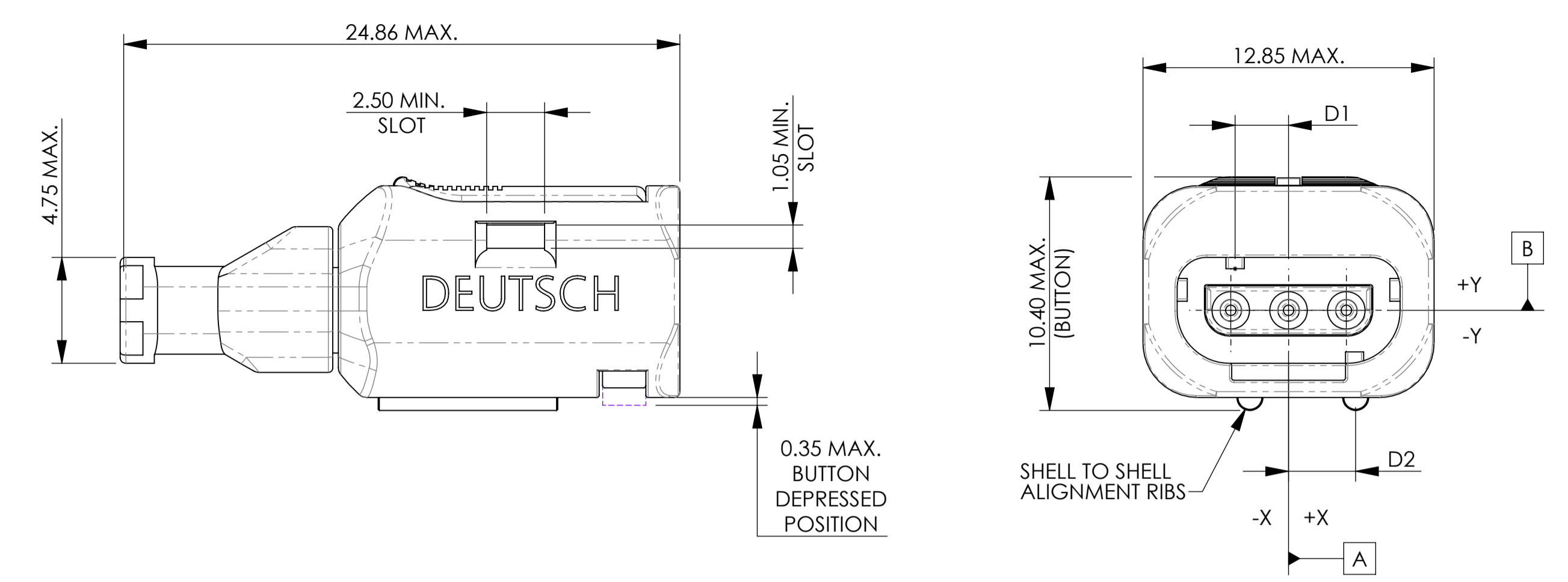

COORDINATE POSITIONS OF CONTACTS (3 WAY CONNECTOR ONLY)		
CONTACT POSITION (ID)	CONTACT LOCATION	
	X AXIS (mm)	Y AXIS (mm)
1	-2.54	0
2	0	0
3	2.54	0

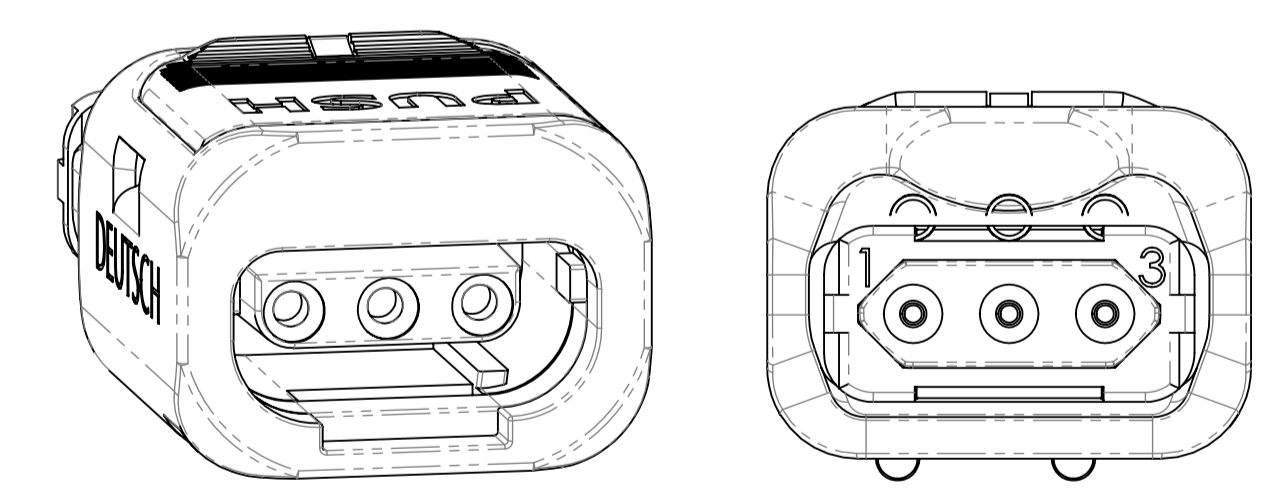
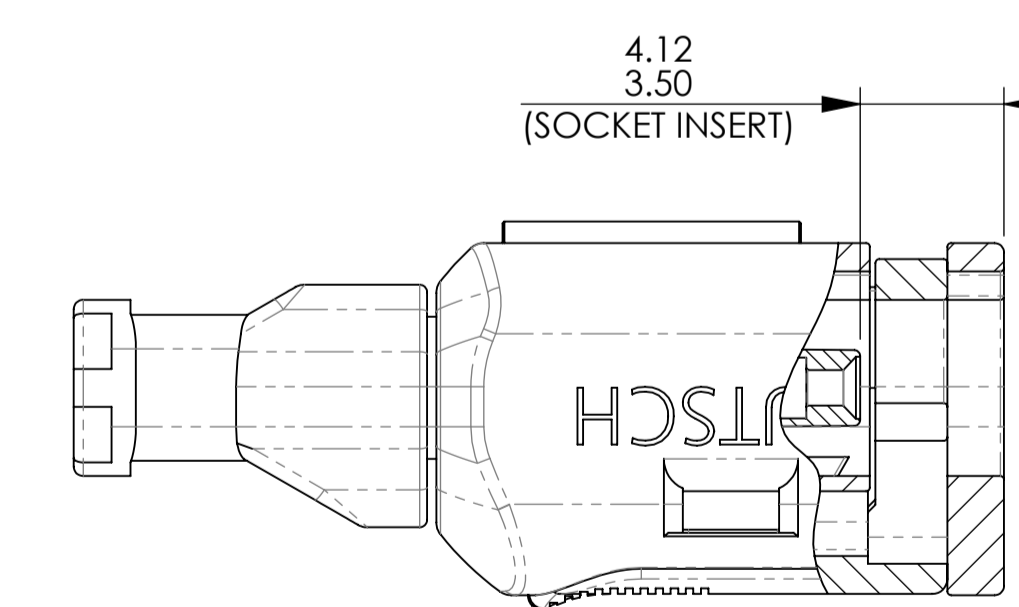
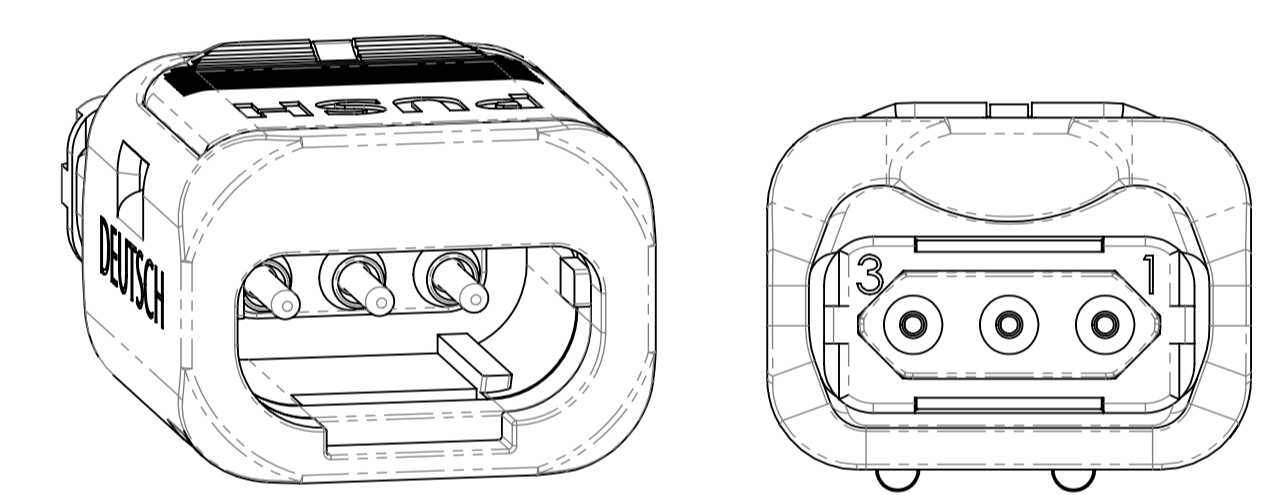
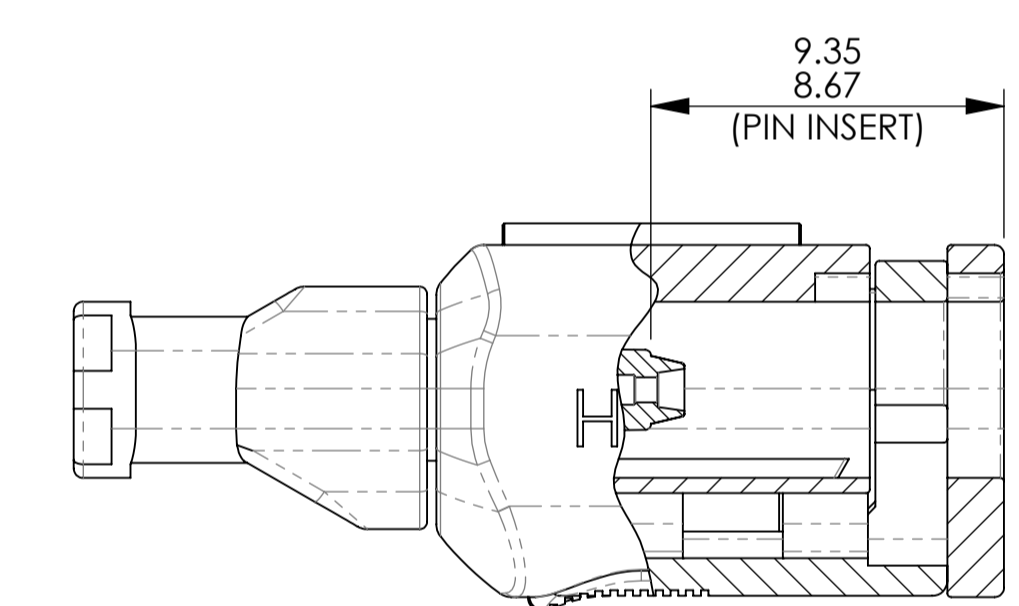

IF IN DOUBT, ASK

BS8888 THIRD ANGLE PROJECTION	MATERIAL: SEE NOTES	FINISH:	
	UNLESS OTHERWISE STATED: DIMENSIONS: mm [INCHES]	TITLE: 369 PLUG CONNECTOR, ENVELOPE DRAWING	
IF IN DOUBT, ASK	SIZE: A1	SCALE: 5:1	DRAWING NUMBER: 611252-ENV
			SHEET: 1 OF 2
			ISSUE: AB

AB	DUK70190	JCB	RAM	NDL	CEO	04/02/2019
ISSUE	CHANGE NOTE	DRAWN	CHECKED	APP. ENG.	APP. MARKETING	DATE

9 WAY CONNECTOR

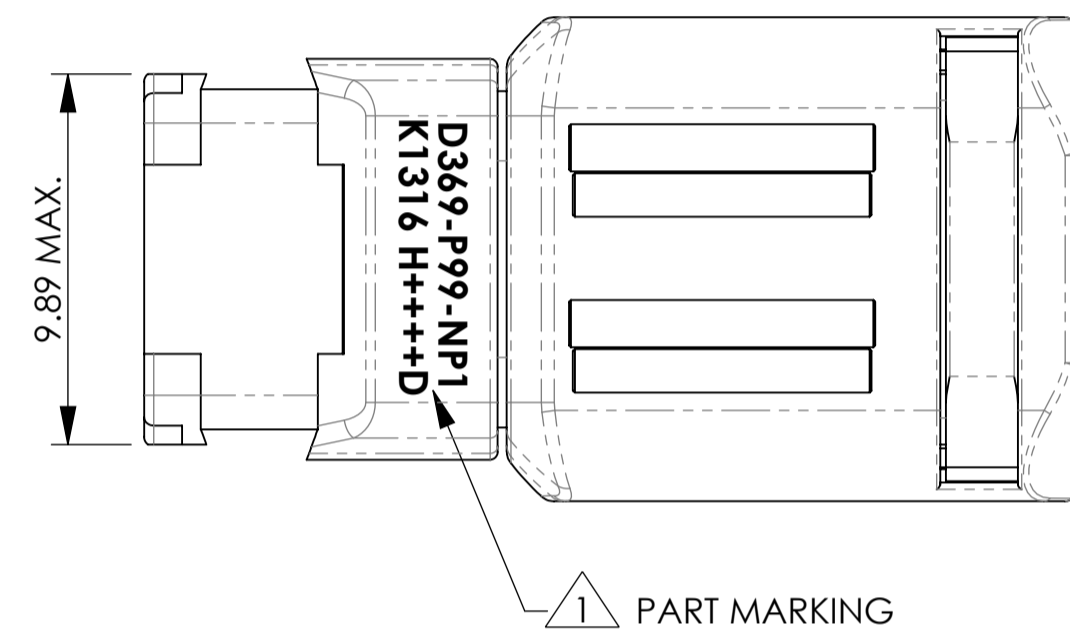
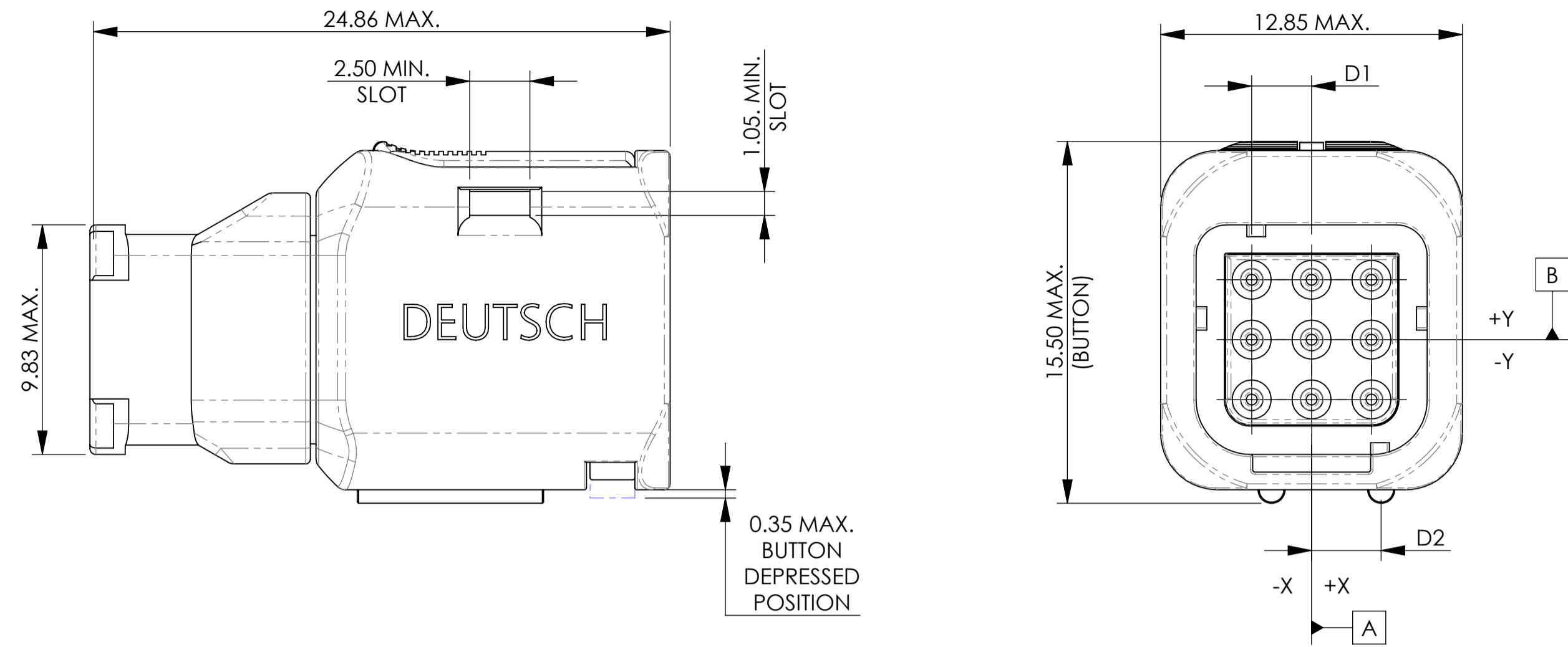

COORDINATE POSITIONS OF CONTACTS (9 WAY CONNECTOR ONLY)

CONTACT POSITION (ID)	CONTACT LOCATION	
	X AXIS (mm)	Y AXIS (mm)
1	-2.54	2.54
2	0	2.54
3	2.54	2.54
4	2.54	0
5	0	0
6	-2.54	0
7	-2.54	-2.54
8	0	-2.54
9	2.54	-2.54

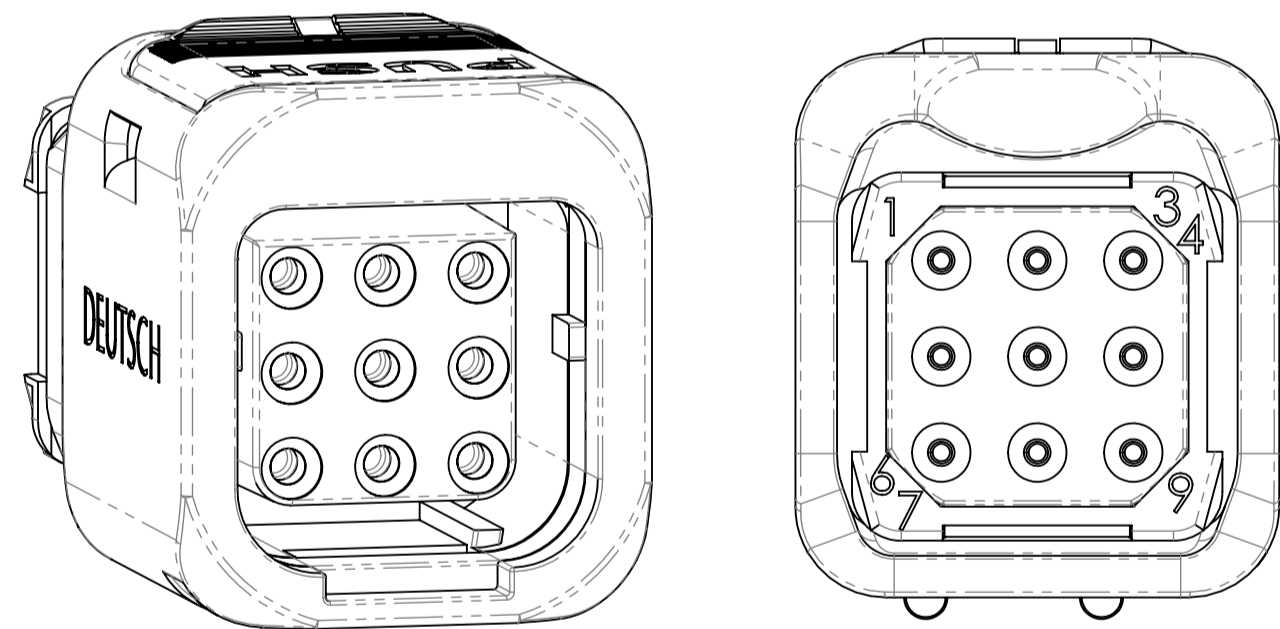
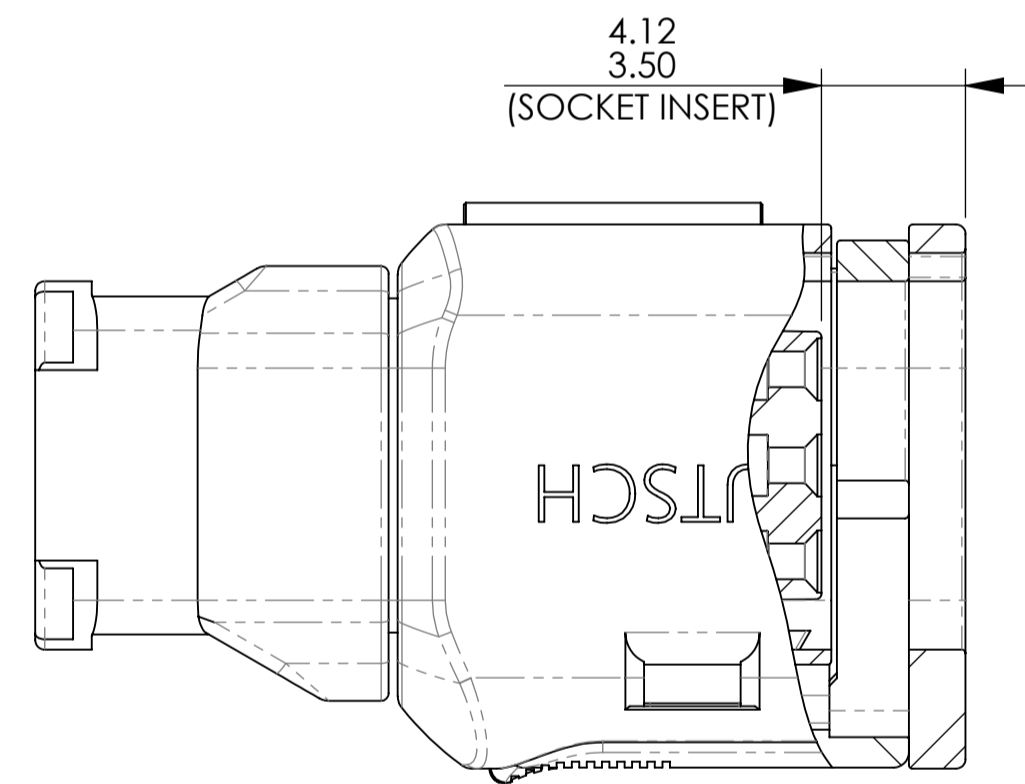

SOCKET / FEMALE CONTACT CAVITY IDENTIFICATION ON REAR

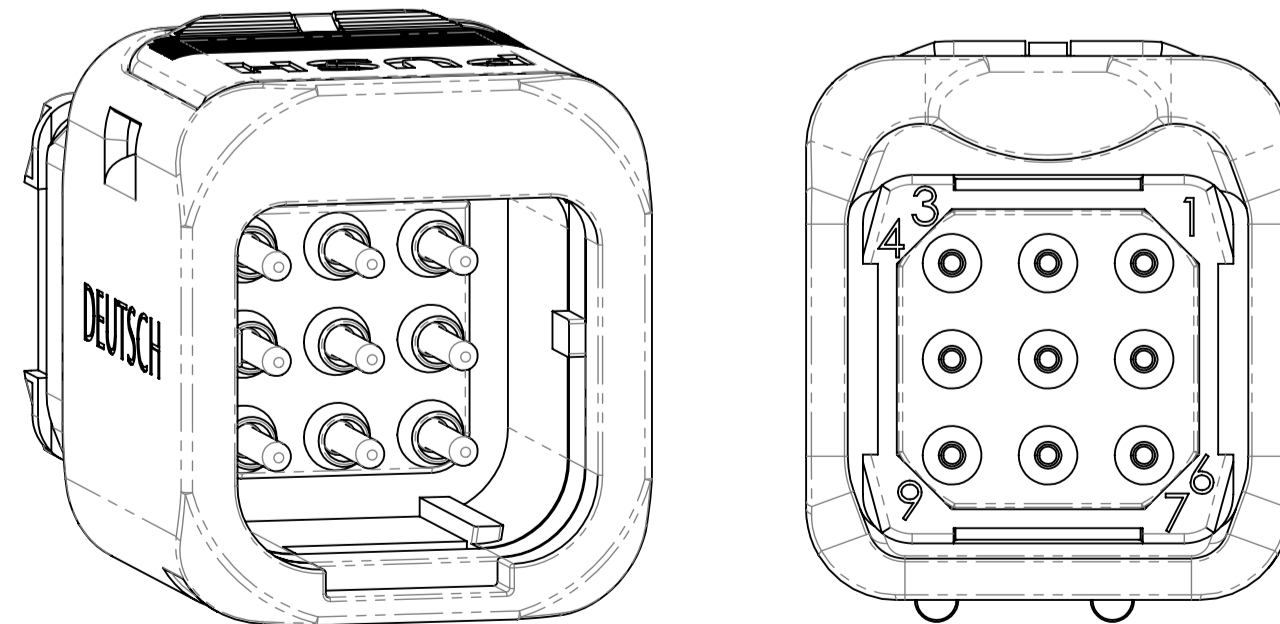
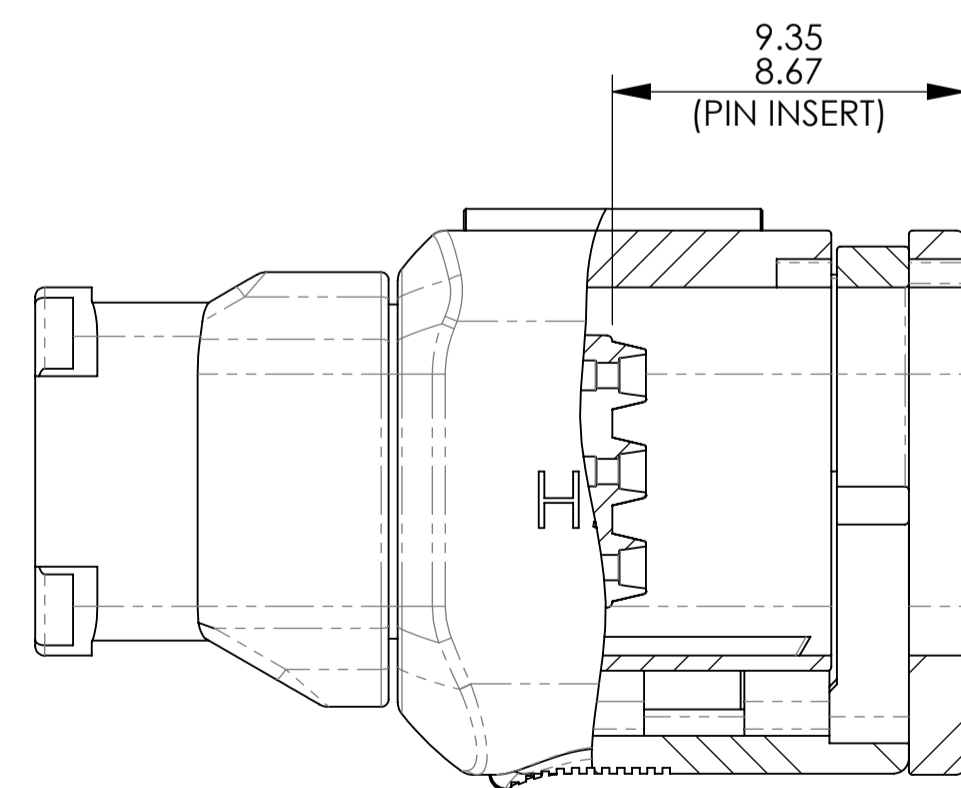

PIN / MALE CONTACT CAVITY IDENTIFICATION ON REAR

6 WAY CONNECTOR

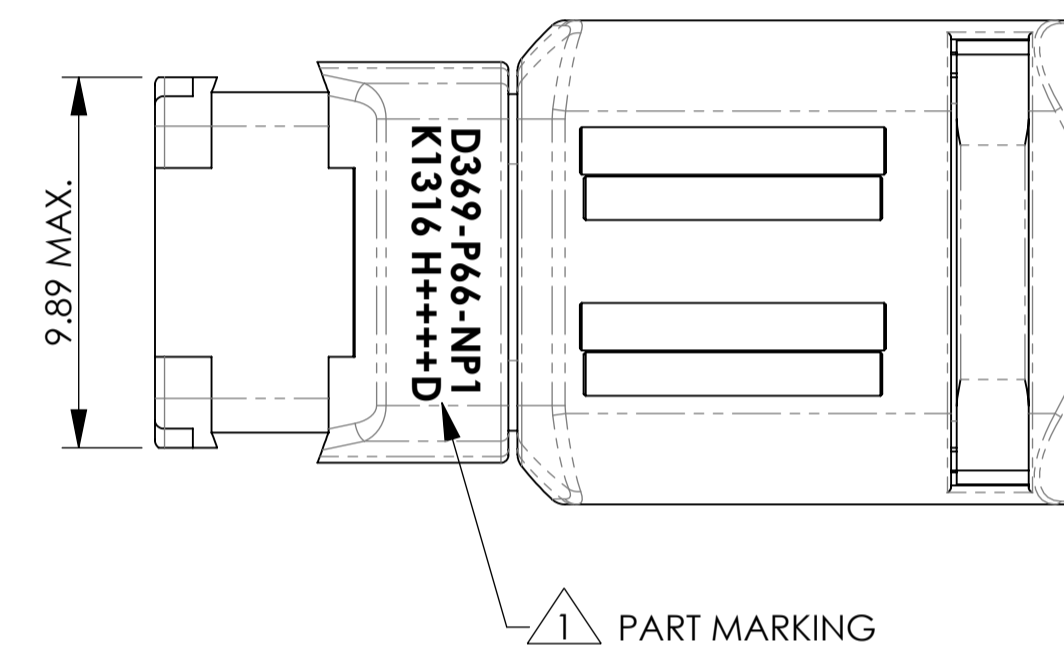
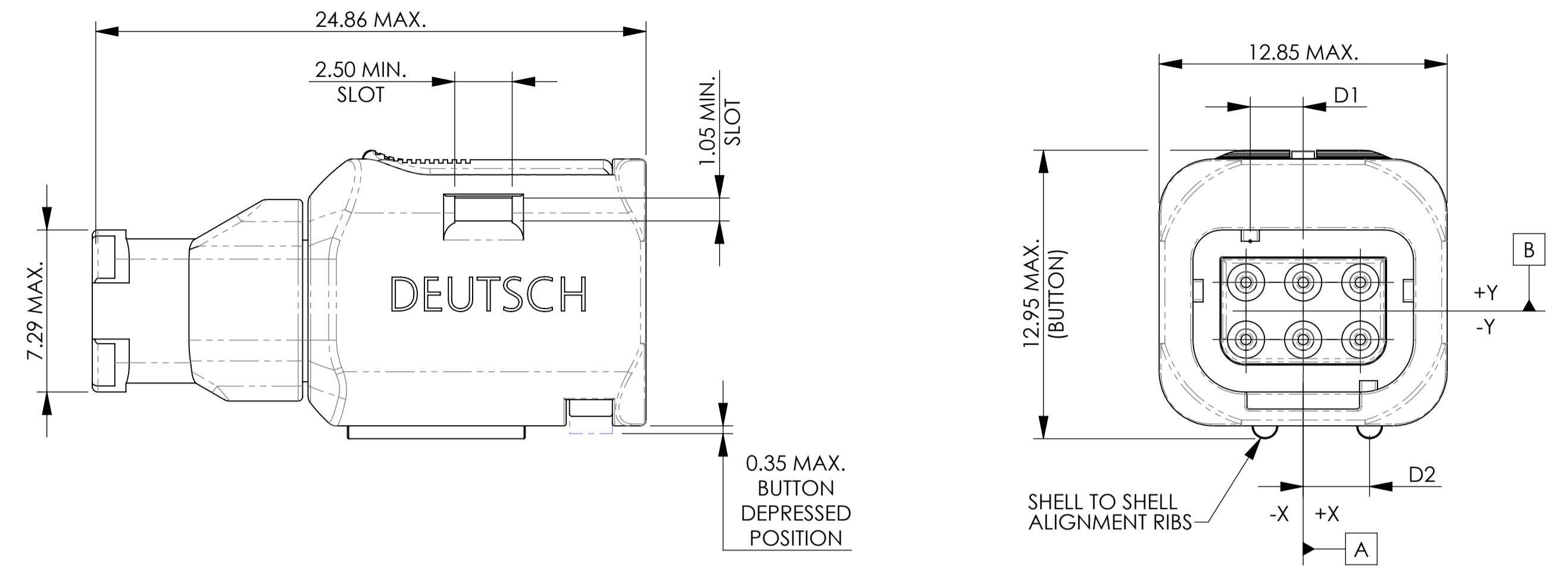

COORDINATE POSITIONS OF CONTACTS (6 WAY CONNECTOR ONLY)

CONTACT POSITION (ID)	CONTACT LOCATION	
	X AXIS (mm)	Y AXIS (mm)
1	-2.54	1.27
2	0	1.27
3	2.54	1.27
4	2.54	-1.27
5	0	-1.27
6	-2.54	-1.27

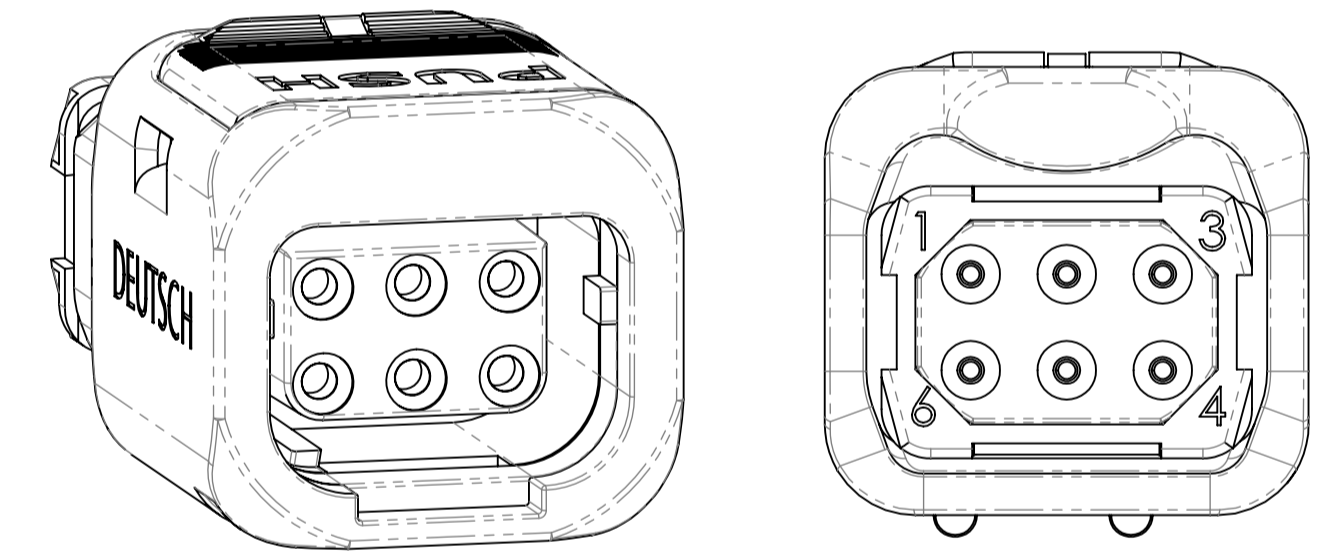
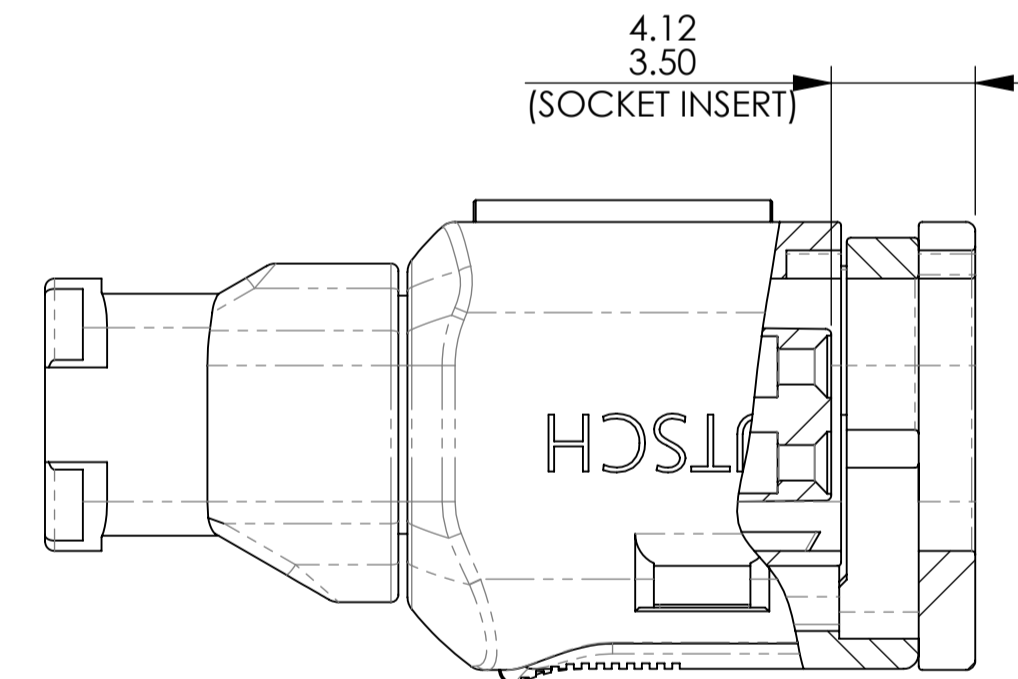

SOCKET / FEMALE CONTACT CAVITY IDENTIFICATION ON REAR

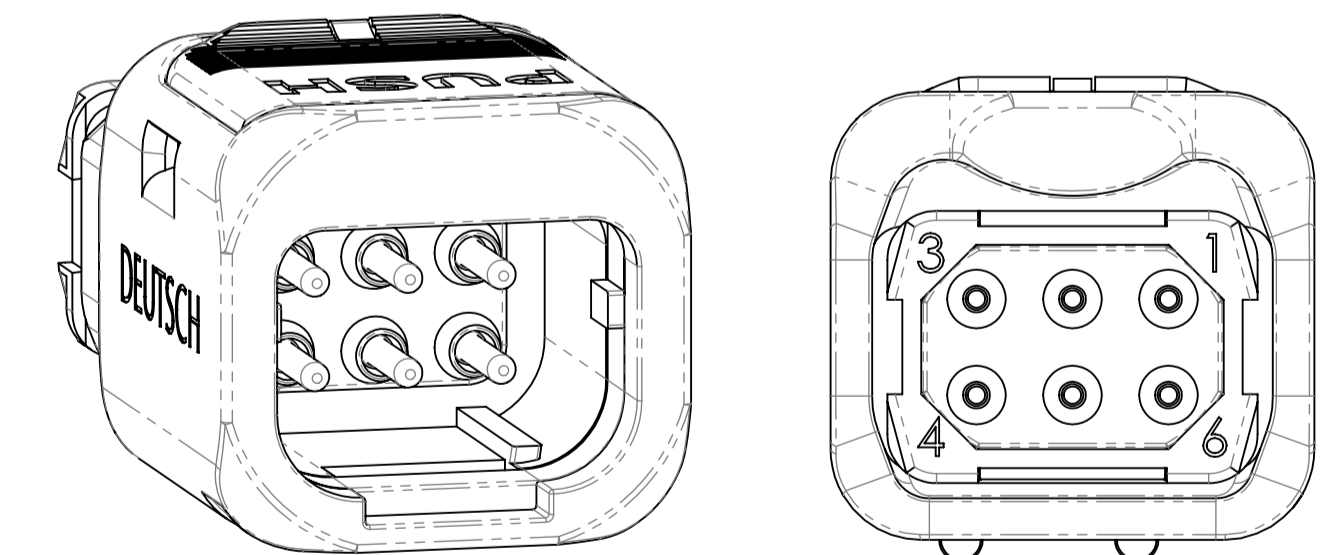
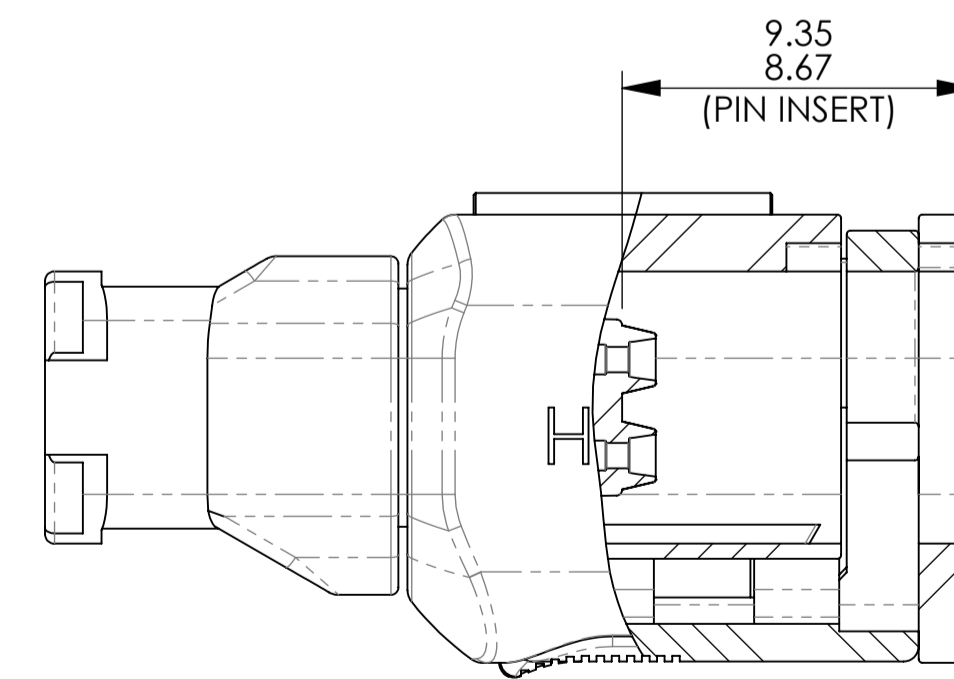

PIN / MALE CONTACT CAVITY IDENTIFICATION ON REAR

BS8888 THIRD ANGLE PROJECTION	MATERIAL: SEE NOTES	FINISH:	
UNLESS OTHERWISE STATED: DIMENSIONS: mm [INCHES]	TITLE: 369 PLUG CONNECTOR, ENVELOPE DRAWING	TYPE: CUSTOMER DRAWING	
IF IN DOUBT, ASK	SIZE: A1	SCALE: 5:1	DRAWING NUMBER: 611252-ENV
			SHEET: 2 OF 2
			ISSUE: AB