

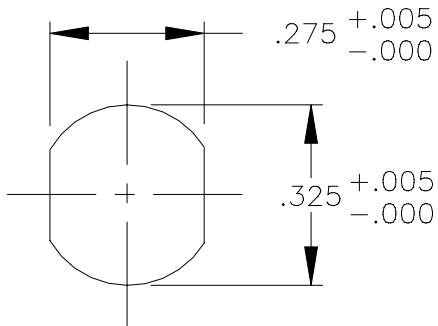

REVISIONS			
LTR	DESCRIPTION	DATE	APPROVED
N/C	INITIAL RELEASE PER DCR# T-26611	6/15/2000	M.HIGGY
A	RELEASE PER DCR# T-28039	9/11/2000	M.HIGGY

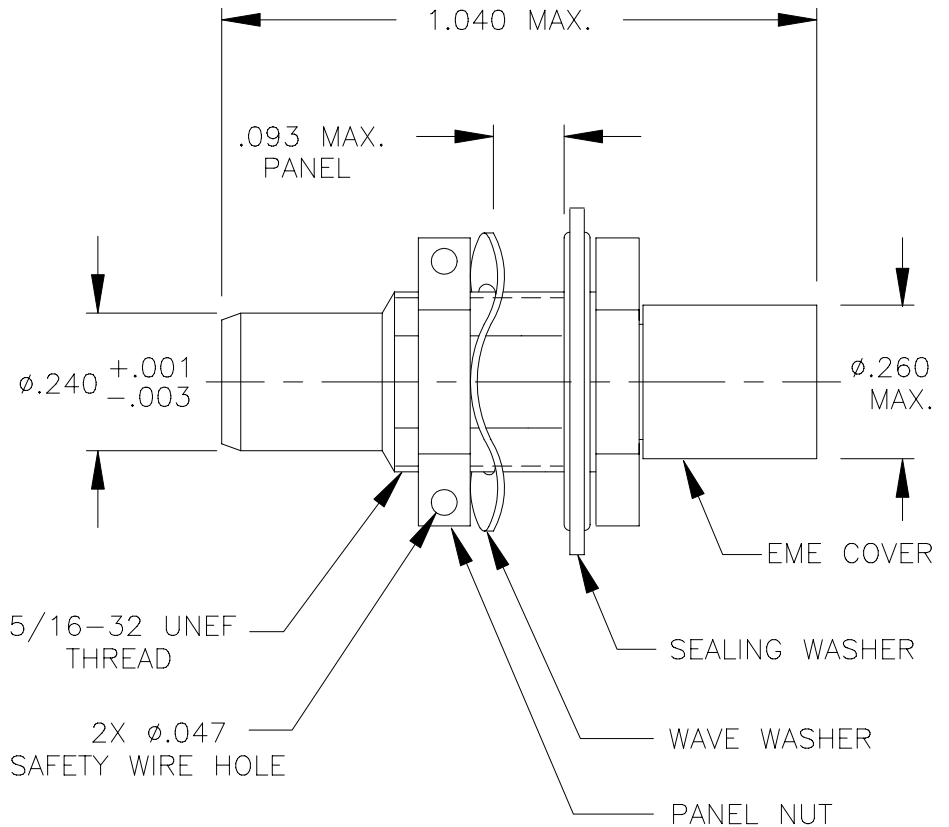
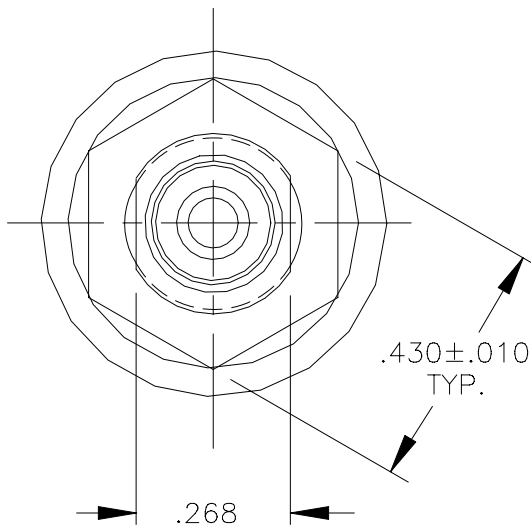

PREFERRED MOUNTING HOLE

**If this document is printed it becomes uncontrolled.
Check with the web for latest revision.**

SPECIFICATION CONTROL DRAWING

UNLESS OTHERWISE SPECIFIED DIMENSIONS ARE IN INCHES. METRIC DIMENSIONS ARE IN BRACKETS.

DECIMALS
 .XXX ± .005 [— mm]
 .XX ± — [— mm]
 ANGLES
 .X ± —
 WEIGHT
 — lbs [— g]

DRAWN	ZS.O.	6/1/2000
CHECKED		
APPROVED	M.HIGGY	6/15/2000
CAD NAME:	T28039a.DWG	
RPN. NO.	171246-000	

THIRD ANGLE PROJECTION

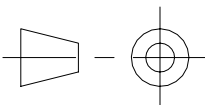

Raychem

RAYCHEM CORPORATION
 300 CONSTITUTION DRIVE
 MENLO PARK, CALIFORNIA 94025

TITLE

JACK, DUMMY
 CONNECTOR, SUBMINIATURE,
 THREADED COUPLED

SIZE	CODE IDENT. NO.	DWG. NO.	REV
A	06090	D-621-0412-JD	A
DO NOT SCALE THIS DRAWING		SCALE: NONE	SHEET 1 OF 2



SPECIFICATIONS

1.0 MATERIALS AND FINISHES

- 1.1 HOUSING BODY: BeCu ALLOY, ASTM B196, TB00 OR TD04,
TIN PLATED PER MIL-T-10727
OVER NICKEL PER MIL-C-26074
 - 1.2 INSULATION (MIP): POLYETHERSULFONE
 - 1.3 PANEL NUT: BRASS ALLOY PER ASTM B16,
TIN PLATED PER MIL-T-10727
OVER NICKEL PER MIL-C-26074
 - 1.4 WAVE WASHER: SPRING STEEL OR BeCu PER ASTM B194
TIN PLATED PER MIL-T-10727
OVER NICKEL PER MIL-C-26074
 - 1.5 SEALING WASHER: ELASTOMER: SILICONE PER ASM-3304
WASHER: CRES PER MIL-S-5059 HALF HARD
OR ANNEALED PASSIVATE PER QQ-P-35
 - 1.6 EME COVER: STAINLESS STEEL & 30300 COND. A
(TYPE 303) PER ASTM A582.
PASSIVATED PER QQ-P-35.
- 2.0 GENERAL CHARACTERISTICS
- 2.1 OPERATING TEMPERATURE: -65°C TO 125°C
 - 2.2 MATING COUPLING TORQUE: 10 INCH/LBS MAX.
 - 2.3 PANEL NUT TORQUE: 10-15 INCH/LBS (WHEN INSTALLING IN PANEL)
- 3.0 INTENDED USE THIS PRODUCT IS INTENDED TO PROVIDE A BULKHEAD
MOUNTED SEALED CAP TO A D-621-0411 PLUG.

**If this document is printed it becomes uncontrolled.
Check with the web for latest revision.**

CAD NAME: T28039b.DWG	DRAWN	ZS.O.	6/1/2000	SIZE	CODE IDENT. NO.	DWG. NO.	REV
	ISSUED			A	06090	D-621-0412-JD	A
				DO NOT SCALE THIS DRAWING		SCALE: NONE	SHEET 2 OF 2