

REVISIONS

P	LTR	DESCRIPTION	DATE	DWN	APVD
	A	INITIAL DRAWING	12SEP2019	VM	DH

Electrical Specifications (-55°C to +105°C unless otherwise specified)

Input

Input supply voltage range (Vcc)	3.8 - 32 Vdc
Input current (max.) @ 5Vdc	15mA _{dc}
Must turn-on voltage	3.8V _{dc}
Must turn-off voltage	1.5V _{dc}
Reverse voltage protection	-32V _{dc}

I/O

Dielectric strength (min.)	1,500V rms/60 Hz.
Insulation resistance (min.) @ 500V _{dc}	10 ⁹ ohms
Capacitance (max.)	10pF

Output

Output current rating (max.)	2A rms (Fig. 2, Note 1)
Surge current (max.), 16ms @ 25°C (max.)	8A pk (Fig. 1, Note 3)
Continuous load voltage (max.)	250V rms
Transient blocking voltage (max.)	500V pk
Frequency range	40 - 440 Hz.
Output voltage drop (max.) @ 1A load current	1.5V rms
Off-state leakage current (max.) @ 250V rms/400 Hz.	1mA rms
Turn-on time (max.)	1/2 cycle
Turn-off time (max.)	1 cycle
Off-state dv/dt (min.), with snubber	200V /μs (Note 2)
Zero voltage turn-on window (max.)	10V
Wave distortion (max.)	4V rms
Output chip junction temperature (max.)	130°C
Thermal resistance (max.), junction to ambient	65°C/W
Thermal resistance (max.), junction to case	15°C/W

Notes

1. Operation at elevated load currents up to 2 amps is dependent on the use of suitable heatsink to maintain case temperature.
2. Recommended output snubber: R = 100 ohms (1/2 W), C = .01μF (600V).
3. Heating of output chip during and after a surge may cause loss of output blocking capability until junction temperature falls below maximum rating.

Input Characteristics

- Input Voltage Range** — 3.8 – 32 Vdc
- Pick-up Voltage** — 3.8 Vdc
- Dropout Voltage** — 1.5 Vdc
- I/O Dielectric** — 1500 Vrms

Output Characteristics

- Max. Output Current (Continuous, 25°C)** — 2 Arms
- Max. Output Voltage** — 250 Vrms
- Peak Over Voltage Rating** — 500 Vpk
- Frequency Range** — 40 – 440 Hz
- Zero Switch Window** — 15 Vpk
- Thermal Resistance** —
Junction to Ambient — 65°C/Watt
Junction to Case — 15°C/Watt

Environmental Characteristics

- Shock** — 1500 G's, 0.5 ms.
- Vibration** — 30 G's, 10 to 3000 Hz
- Operating Ambient Temperature** — -55 to +110°C

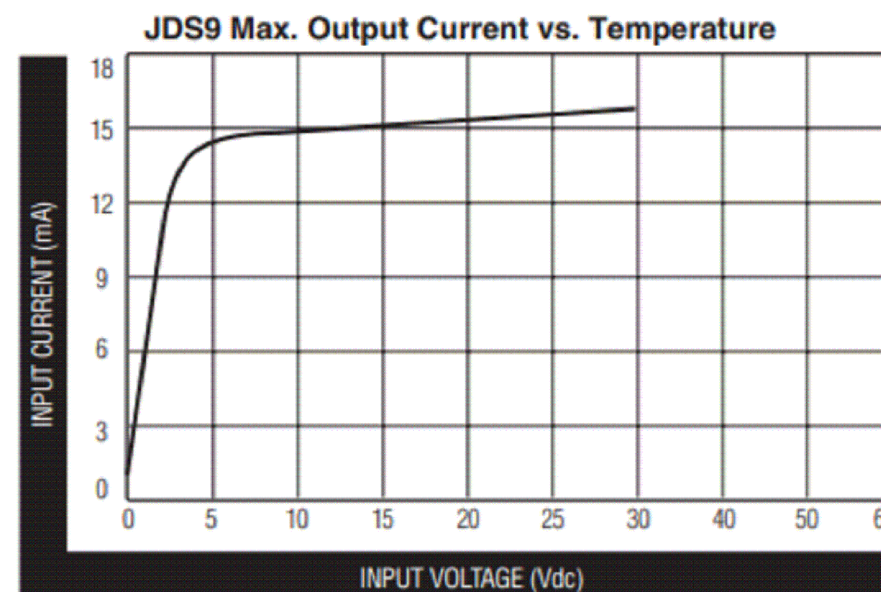
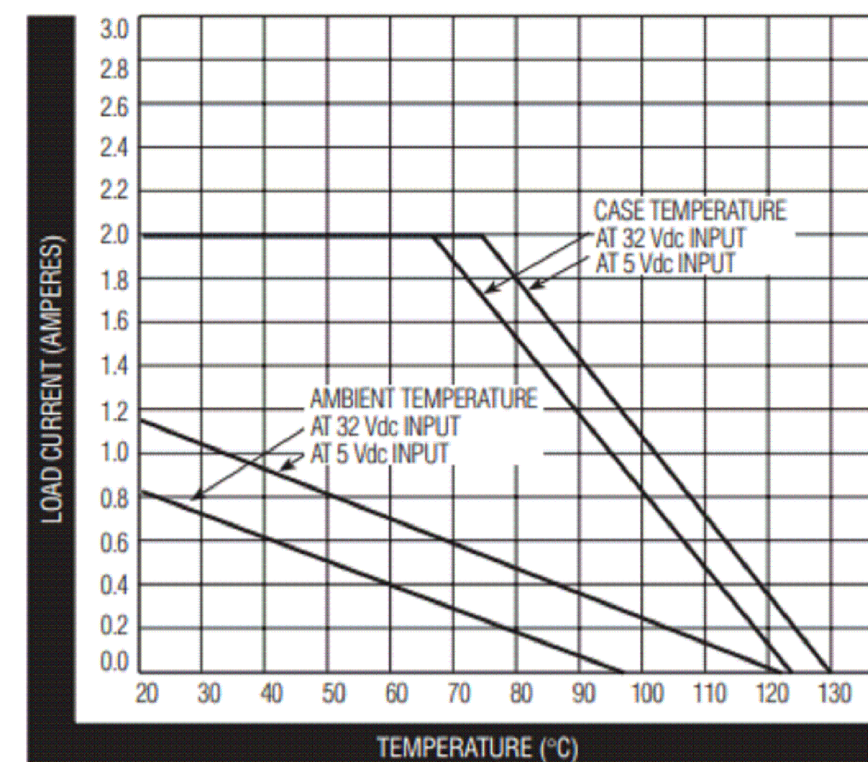

THIS DRAWING IS A CONTROLLED DOCUMENT.		DWN VM 12SEP2019	TE Connectivity		
		CHK RV 12SEP2019			
		APVD DH 12SEP2019	NAME JDS9 SERIES AC RELAY		
DIMENSIONS: INCHES		TOLERANCES UNLESS OTHERWISE SPECIFIED:	PRODUCT SPEC		
		0 PLC ± -	APPLICATION SPEC		
		1 PLC ± -	SIZE A3		
		2 PLC ± -	CAGE CODE -		
		3 PLC ± -	DRAWING NO. C-JDS9-SERIES		
		4 PLC ± -	RESTRICTED TO -		
		ANGLES ± -	SCALE NTS		
MATERIAL -		FINISH -	SHEET 1 OF 2		
			REV A		
			CUSTOMER DRAWING		

THIS DRAWING IS UNPUBLISHED.

RELEASED FOR PUBLICATION

REVISIONS

© COPYRIGHT - TE Connectivity Ltd.

ALL RIGHTS RESERVED.

P	LTR	DESCRIPTION	DATE	DWN	APVD
-	-	SEE SHEET 1	-	-	-

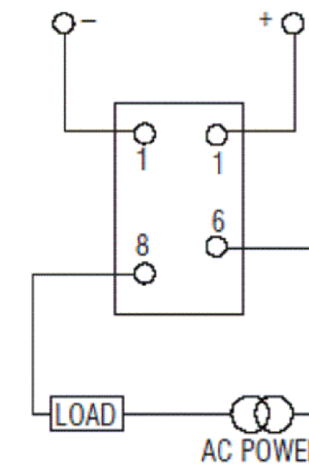
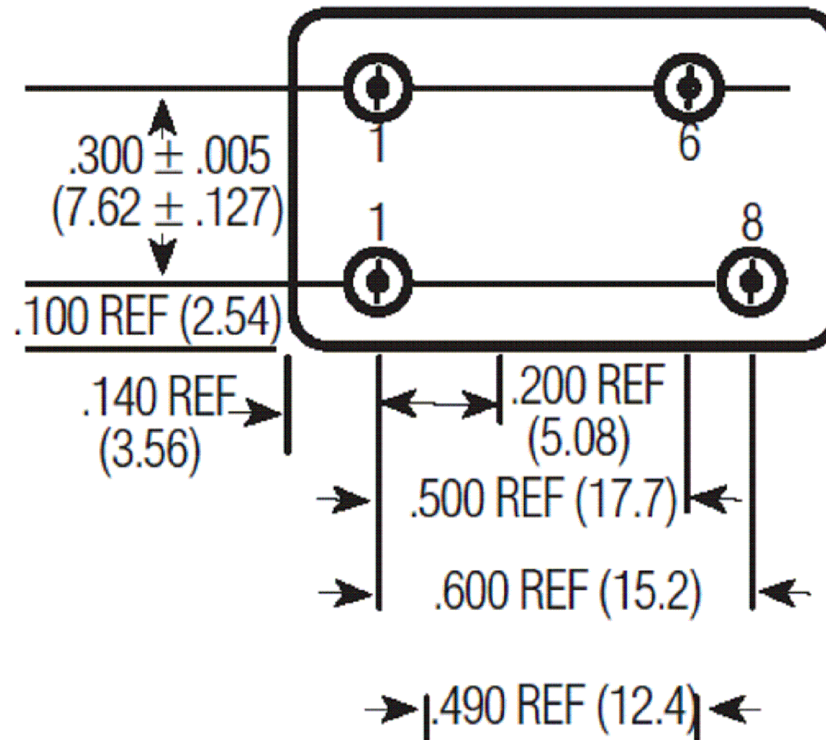
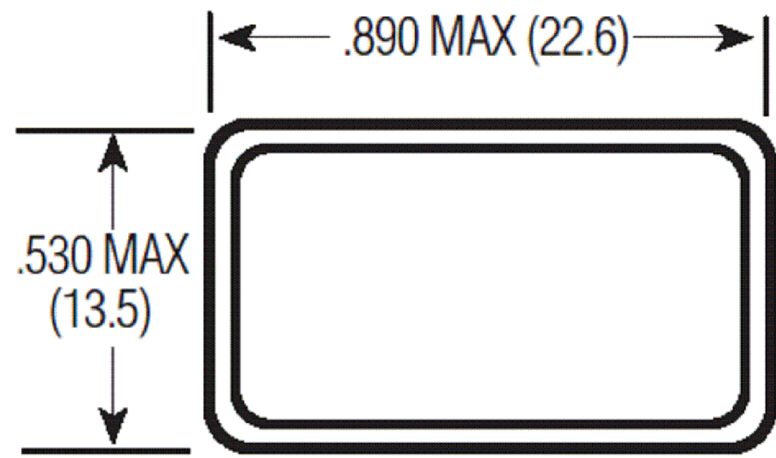

Terminal View

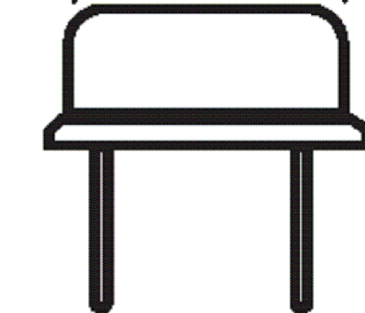
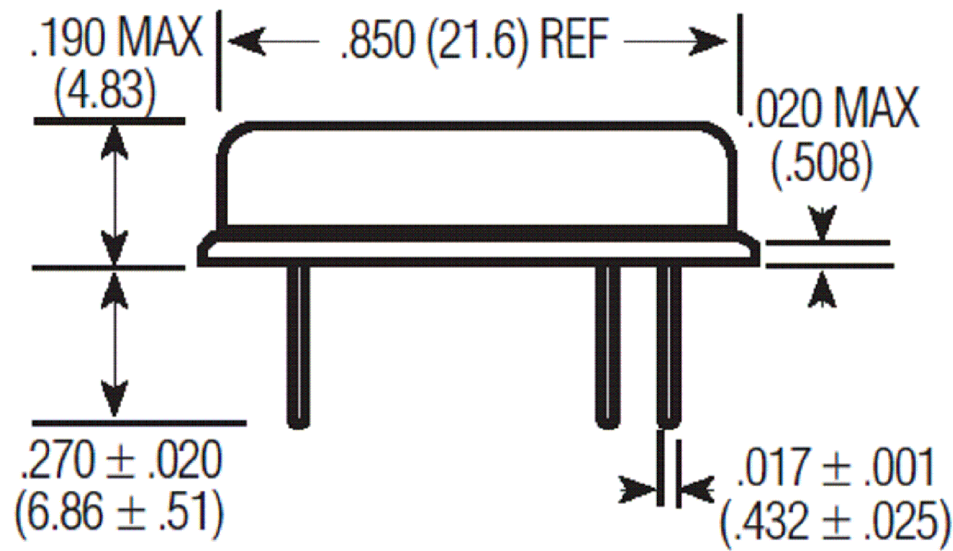

Product Facts

- Hermetically sealed
- Thick film hybrid construction
- Optically isolated
- Zero voltage turn-on
- Qualified to MIL-R-28750/9

ALL DIMENSIONS ARE IN INCHES(MM)

THIS DRAWING IS A CONTROLLED DOCUMENT.		DWN VM 12SEP2019			
		CHK RV 12SEP2019			
DIMENSIONS: INCHES	TOLERANCES UNLESS OTHERWISE SPECIFIED:	APVD DH 12SEP2019	NAME JDS9 SERIES AC RELAYS		
	0 PLC ± - 1 PLC ± - 2 PLC ± - 3 PLC ± - 4 PLC ± - ANGLES ± -	PRODUCT SPEC -	RESTRICTED TO -		
MATERIAL -	FINISH -	APPLICATION SPEC -	SIZE A3	CAGE CODE -	DRAWING NO G-JDS9-SERIES
		WEIGHT -	SCALE NTS		
		CUSTOMER DRAWING	SHEET 2 of 2		REV A