

DRAWING NO: NGA0785-0830-C
THIS DRAWING IS A CONTROLLED DOCUMENT



ARMOUR RODS

CATALOGUE NUMBER: NGA0785-0830 SUITS CONDUCTOR

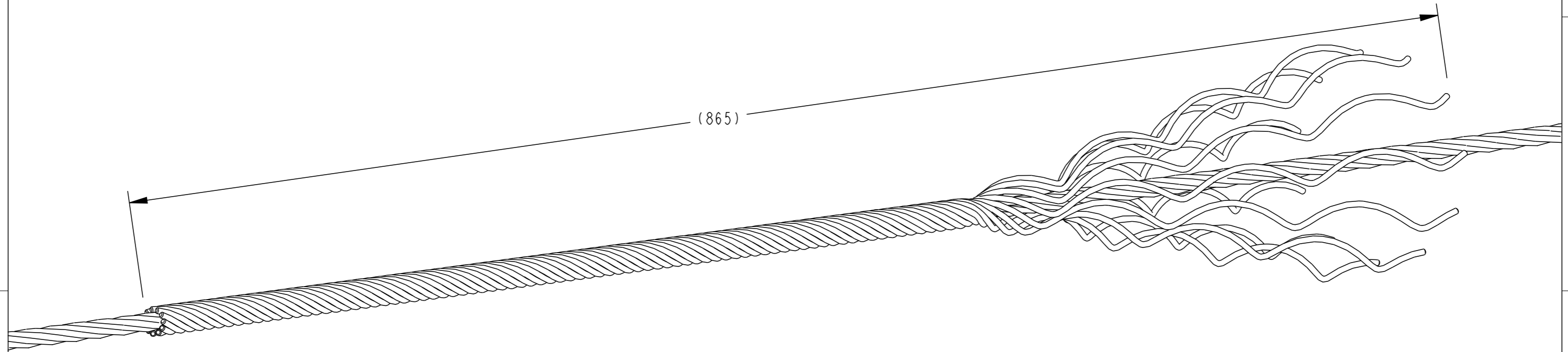

STRANDING	COND. TYPE	DIAMETER	FITTING LAY
7/2.75	SC/GZ	8.25	RIGHT HAND
7/12 (7/0.104")	SC/GZ	7.92	RIGHT HAND



TECHNICAL SPECIFICATIONS;

CATALOGUE NUMBER: NGA0785-0830
DESCRIPTION: NON-TENSION GALVANIZED STEEL ARMOUR RODS
MATERIAL: HEAVILY GALVANIZED STEEL WIRE.
NUMBER OF RODS: 10
ROD DIAMETER: 2.64mm
OVERAL LENGTH: 865mm
END FINISH: CHAMFERED
FITTING LAY DIRECTION: RIGHT HAND
COLOUR CODED: WHITE
RODS ARE LABELED, BUNDLED IN A SET AND TAPED AT BOTH ENDS.

BOX LABEL

P/N: NGA0785-0830
ID:
DESCRIPTION:
NON-TENSION GALV-STEEL ARMOUR RODS
7/2.75 SC/GZ
7/12 SC/GZ
RANGE: 7.85 - 8.30
COLOUR-CODE: WHITE
QTY: 30 **WEIGHT:** **BATCH:**

PRODUCT LABEL



NGA0785-0830
7/2.75 SC/GZ
7/12 SC/GZ

WEIGHT: 0.40 kg
BATCH NO:
MONTH/YEAR:

THIS INFORMATION IS CONFIDENTIAL AND PROPRIETARY TO TE CONNECTIVITY CORPORATION AND ITS WORLDWIDE SUBSIDIARIES AND AFFILIATES. IT MAY NOT BE DISCLOSED TO ANYONE, OTHER THAN TE CONNECTIVITY PERSONNEL, WITHOUT WRITTEN AUTHORIZATION FROM TE CONNECTIVITY CORPORATION, AUSTRALIA.

LOC							IMPLIED NOTES BURRS AND SHARP EDGES REMOVED SCREW THREADS ARE TO AS 1275 DO NOT WORK TO DIMS MARKED REF SURFACE FINISH 6.3 U.N.O. DIMS ARE IN mm. DO NOT SCALE	IMPLIED TOLERANCES HOLE DIA AND LOCATIONS. ±0.5mm DIMENSIONS UP TO 30mm. ±1.5mm DIMENSIONS OVER 30mm. ±5% UP TO A MAX OF ±5mm ANGULAR DIMENSIONS. ±5°	TCPN -	PART Alias UTX/DUL NGA0785-0830	TITLE NON-TENSION GALV-STEEL ARMOUR RODS (NGA) FITTING COND RANGE: Ø7.85 - Ø8.30			
DIST	—	I	NEW RELEASE	27-03-2014	AG	AT	MATERIAL DESC HEAVILY GALVANIZED STEEL WIRE	MATERIAL NO -	MATL SPEC/STD/DRG NO -	PROCESS SPEC HEAT TREAT/PLATING NO -	Cat No NGA0785-0830	DRAWN AG	DATE 27-03-2014	TE Connectivity 2/3 Corella Close Berkeley Vale NSW 2261 Australia
POS	REV	REVISION RECORD		DATE	DWN	APVD	MATERIAL NO -	MATL SPEC/STD/DRG NO -	PROCESS SPEC HEAT TREAT/PLATING NO -	SIZE A3	PROJECTION 3RD ANGLE	SCALE NTS	DRAWING NO NGA0785-0830-C	SHEET OF 1 1

Format: generic_m03.au.r1.frm 4

Template: tec_generic_a3_metric.au.r1.drw 3

Dwg No from P1 Mod Fam Tbl: 2 >AUXXXXX