

THIS DRAWING IS UNPUBLISHED. RELEASED FOR PUBLICATION
 © COPYRIGHT BY TYCO ELECTRONICS CORPORATION. ALL RIGHTS RESERVED.

LOC	DIST	REVISIONS					
		P	LTR	DESCRIPTION	DATE	DWN	APVD
G	14		B	REL PER 0G3A-0625-04	09AUG04	JR	MS

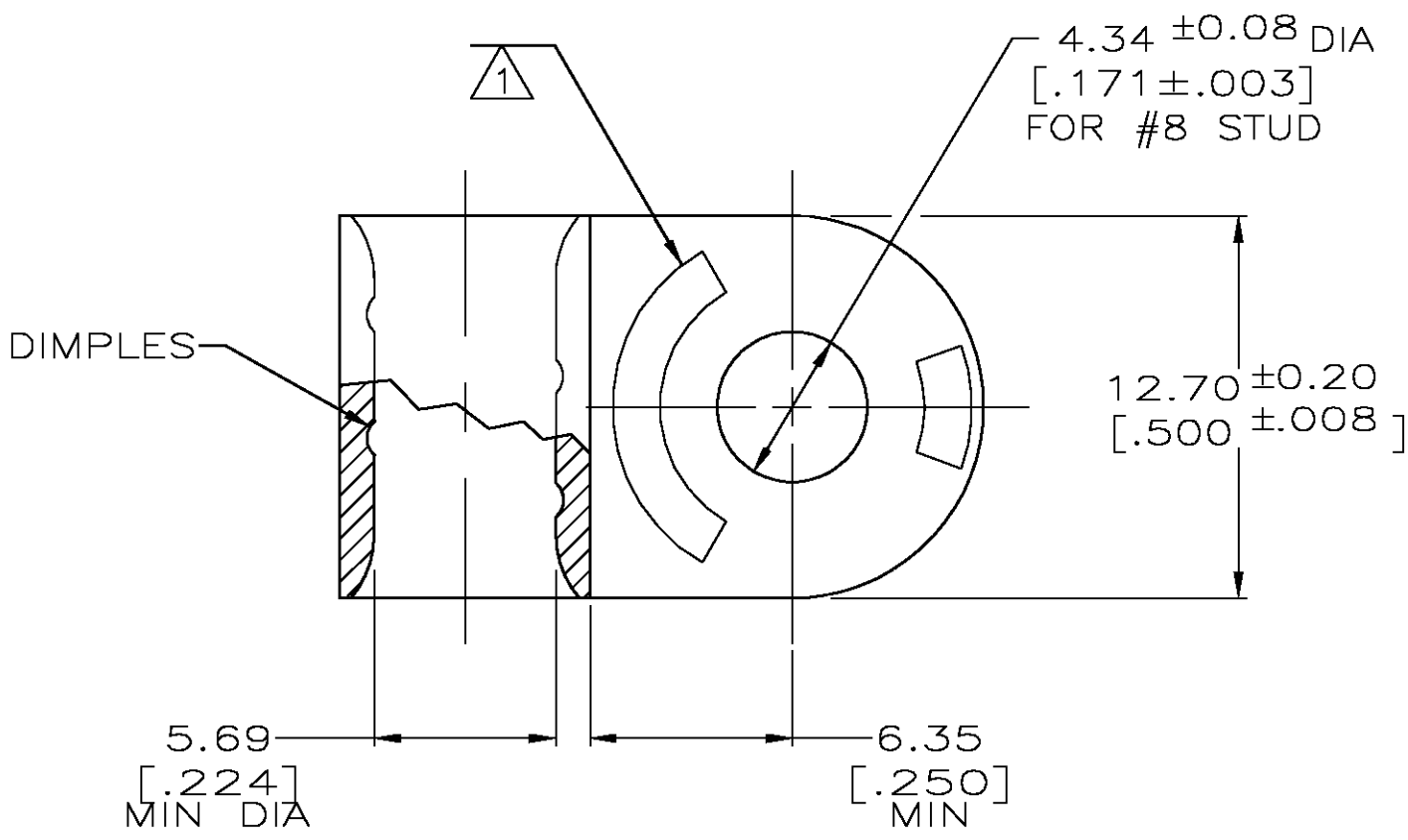

AMP WIRE RANGE	Listed FILE E13288	LR7189 Certified
6 AWG SOLID OR STRANDED	NOT LISTED	NOT CERTIFIED

- △ 1 STAMP AMP 6W* 23-30 APPROX AS SHOWN
- △ 2 COPPER PER ASTM B-152, ANNEALED
- △ 3 NICKEL PLATE 0.00762 [.000300] MIN THK PER QQ-N-290

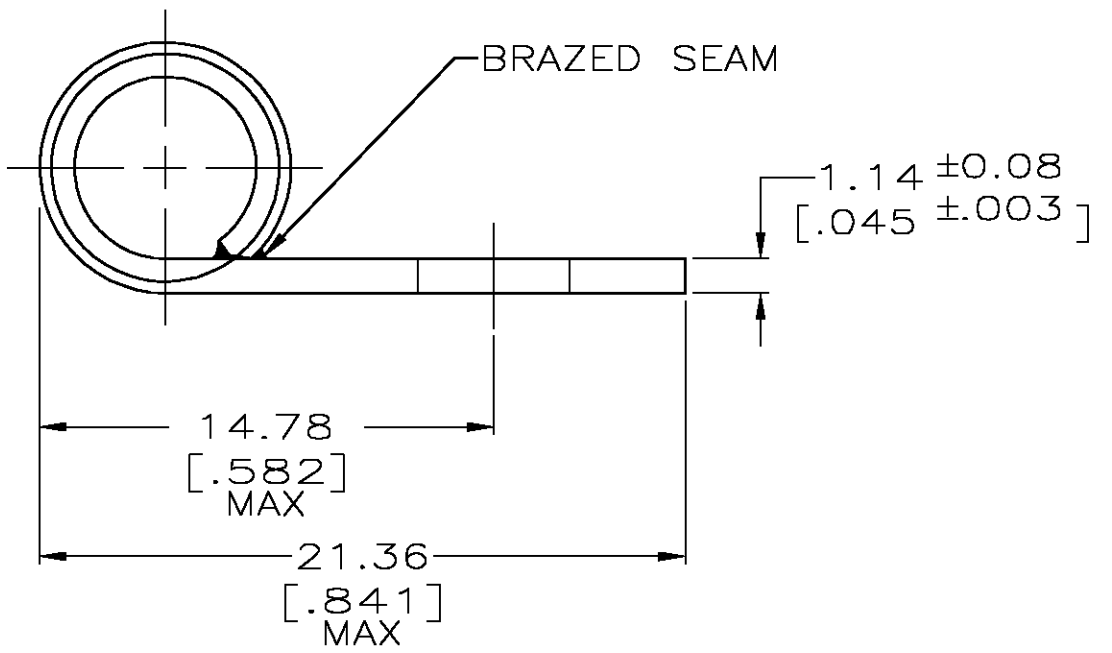

696724-1
TYCO
PART NUMBER

**AMP INCORPORATED
CUSTOMER SERVICE SYSTEMS**

FOR ADDITIONAL PRODUCT INFORMATION OR COPIES OF DRAWINGS AND TECHNICAL DOCUMENTS	PRODUCT INFORMATION CENTER 1-800-522-6752	RECOMMENDED OPERATING TEMPERATURE: 343° C MAX
FOR APPLICATION TOOLING INFORMATION	TOOLING ASSISTANCE CENTER 1-800-722-1111	VOLTAGE RATING: NOT APPLICABLE
FOR ORDER ENTRY	1-800-526-5142	WIRE CROSS SECTIONAL AREA RANGE: 10.5-16.8mm ² [20,800-33,100] CIR MILS SOLID OR STRANDED

THIS DRAWING IS A CONTROLLED DOCUMENT.

DIMENSIONS: mm [INCHES]	TOLERANCES UNLESS OTHERWISE SPECIFIED:
	0 PLC ± -
	1 PLC ± -
	2 PLC ± 0.20 [.008]
	3 PLC ± -
	4 PLC ± -
	ANGLES ± -
MATERIAL	FINISH
- △ 2	- △ 3

DWN JR RUTH 21MAY04		Tyco Electronics Corporation Harrisburg, Pa 17105-3608		
CHK MJ SPICER 21MAY04		NAME TERMINAL, RING TONGUE, FLAG, STRATO-THERM		
APVD MJ SPICER 21MAY04		SIZE A3	CAGE CODE 00779	DRAWING NO C-696724
PRODUCT SPEC	APPLICATION SPEC	WEIGHT	RESTRICTED TO	
CUSTOMER DRAWING		SCALE 4:1	SHEET 1 OF 1	REV B