

REVISIONS					
P	LTR	DESCRIPTION	DATE	DWN	APVD
	B	REVISED PER ECO-19-009164	24JUN2020	KG	DR

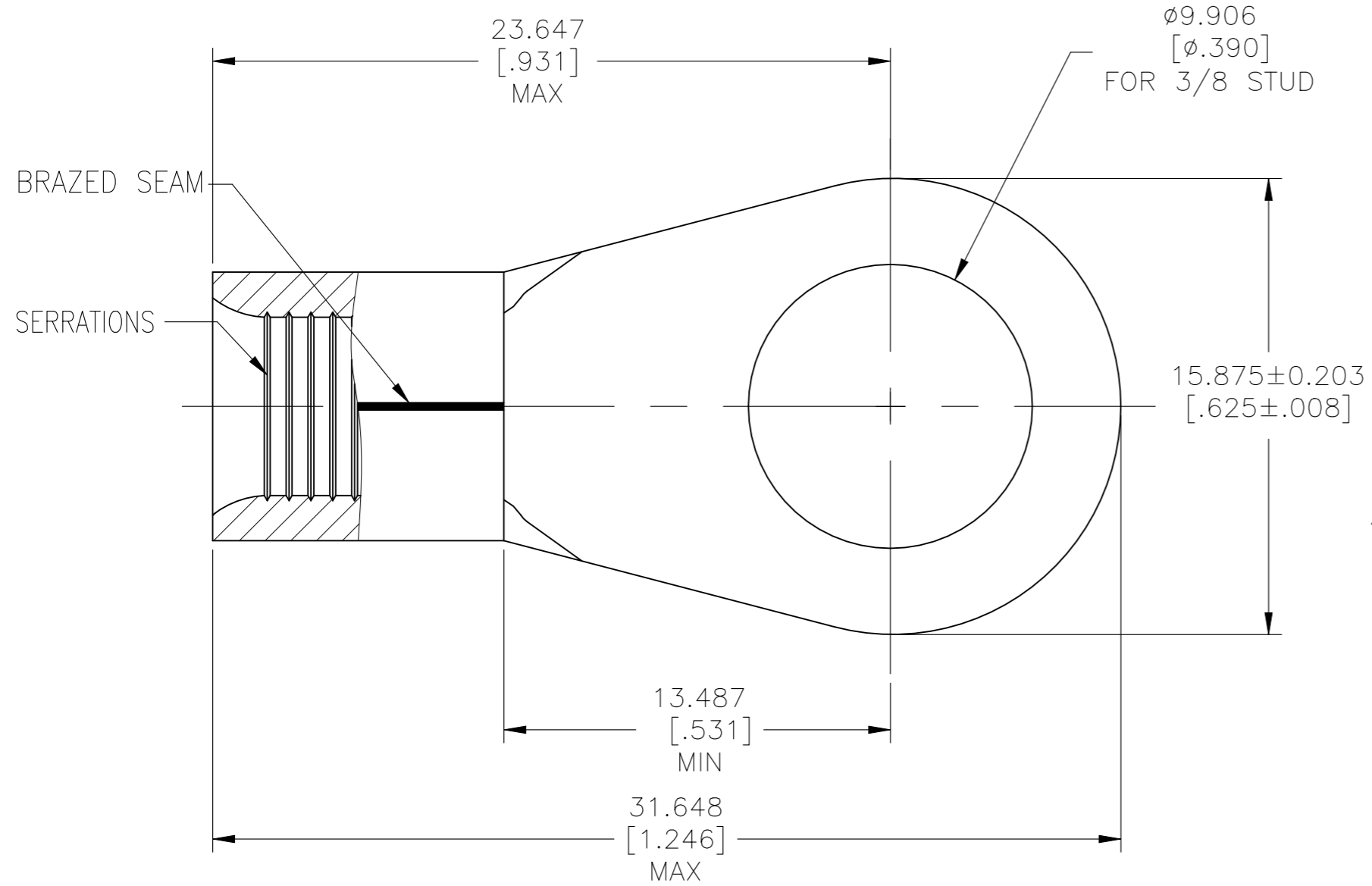

- 1 WIRE RANGE IS FOR 6 AWG. STANDARD WIRE CROSS SECTIONAL AREA RANGE: 20,800-33,100 CMA, STRANDED WIRE
- 2 TERMINAL BODY MATERIAL THK IS 1.448±0.076[.057±.003]
- 3 RECOMMENDED OPERATING TEMP -55°C [131°F] TO +200°C [392°F] FOR HEAT SHRINK TUBING
- 4 HEAT SHRINK TUBING SHELF LIFE OF 18 MONTHS FROM DATE CODE ON LABEL
- △5 TERMINAL BODY PRODUCT SPECIFICATION 108-32046. APPLICATION SPECIFICATION 114-2162

1	8-1190141-0	HIGH AND LOW TEMPERATURE CROSS LINKED FLUOROPOLYMER HEAT SHRINK TUBING 9.53 [.375]MIN ID X 25.400±2.032 [1.000±.080] RT555-3/8-0-SP
1	323172	TERMINAL BODY: COPPER PER ASTM B152 ANNEALED FINISH: NICKEL PLATE 0.00762 [.000300] MIN EXT THK PER SAE AMS QQ-N-290
-1	PART NO	DESCRIPTION

THIS DRAWING IS A CONTROLLED DOCUMENT.		DWN JR RUTH 08DEC09	STE TE Connectivity		
DIMENSIONS: mm [INCHES]		CHK TOM MICHIELUTTI 08DEC09			
TOLERANCES UNLESS OTHERWISE SPECIFIED:		APVD TOM MICHIELUTTI 08DEC09	NAME -		
0 PLC ± -		PRODUCT SPEC	HEAT RESISTANT TERMINAL KIT WIRE SIZE: 6 AWG		
1 PLC ± -		APPLICATION SPEC	SIZE CAGE CODE DRAWING NO RESTRICTED TO		
2 PLC ± -			A3 00779 C-696639 -		
3 PLC ± 0.127[.005]			SCALE 5:1 SHEET 1 OF 1 REV B		
4 PLC ± -					
ANGLES ± 1°					
MATERIAL SEE TABLE		FINISH SEE TABLE			
		CUSTOMER DRAWING			