

THIS DRAWING IS UNPUBLISHED. RELEASED FOR PUBLICATION  
 © COPYRIGHT - By - ALL RIGHTS RESERVED.

LOC	DIST	REVISIONS					
AF	50	P	LTR	DESCRIPTION	DATE	DWN	APVD
		R1		REVISED PER ECR-20-009164	3AUG2020	MK	DH

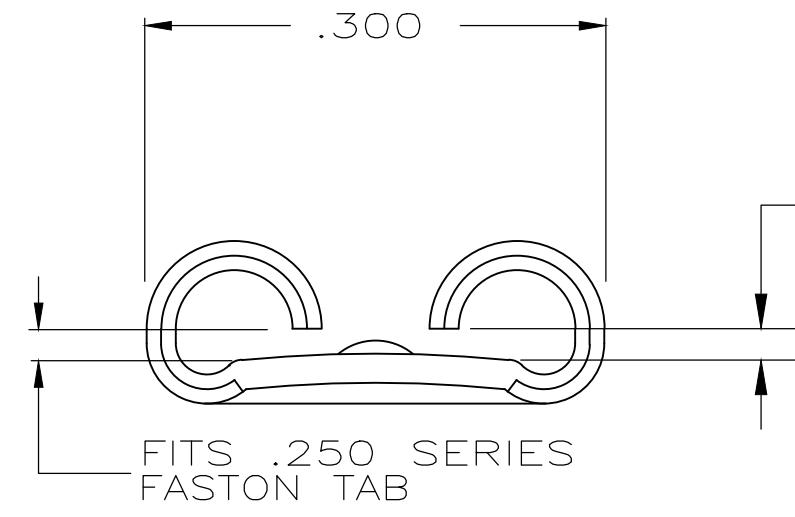
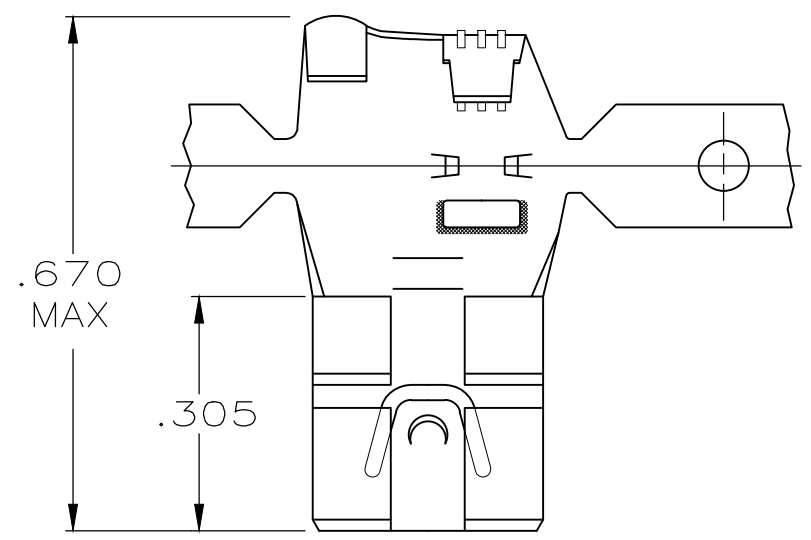

- 1 CONTINUOUS STRIP ON REELS.
- 2 STRESS RELIEVE THIS PART
- 3 THIS PART MUST MATE TO A TAB WITH A HOLE, NOT A DIMPLE.

GAP AS REQUIRED TO MEET FORCE SPECIFICATIONS AND .028MAX

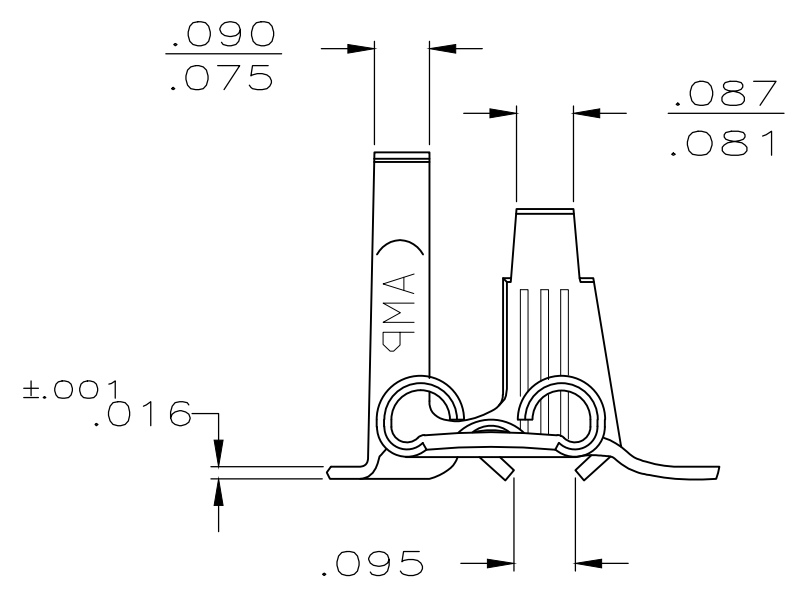

VIEW A-A

OBSOLETE	3	-	.110-.210	18-12	.033-.030	63445-5
	2	TIN	.110-.210	18-12	.033-.030	63445-4
		SILVER	.110-.210	18-12	.032	63445-3
		TIN	.110-.210	18-12	.033-.030	63445-2
		-	.110-.210	18-12	.033-.030	63445-1
	FINISH		INSULATION RANGE	WIRE SIZE	MATING TAB THK	PART NO

THIS DRAWING IS A CONTROLLED DOCUMENT.		DWN JR RUTH 7/10/86	<b>STE</b> TE Connectivity						
DIMENSIONS: INCHES		CHK G YETTER 7/11/86							
TOLERANCES UNLESS OTHERWISE SPECIFIED:		APVD C MEYERS 7/11/86	NAME .250 SERIES FLAG FASTON RECEPTACLE						
0 PLC ± -		PRODUCT SPEC	-						
1 PLC ± -		APPLICATION SPEC	-						
2 PLC ± -		WEIGHT	-						
3 PLC ± .010		SIZE	A3	CAGE CODE	00779	DRAWING NO	C-63445	RESTRICTED TO	-
4 PLC ± -		CUSTOMER DRAWING		SCALE	4:1	SHEET	1 OF 1	REV	R1
ANGLES ± -									
FINISH									
MATERIAL BRASS									