

THIS DRAWING IS UNPUBLISHED. RELEASED FOR PUBLICATION
 © COPYRIGHT 19 BY AMP INCORPORATED. ALL INTERNATIONAL RIGHTS RESERVED.

PROD CODE	LOC	DIST	REVISIONS			
ZONE	LTR	DESCRIPTION	DATE	APPD		
-	DF	XO	0			
			NPR 90-0049 - WAS 89-3321-018	1-31-90	PY	

- FOR USE WITH ECS CABLE P/N 311201
- BRAID CRIMP: USE MILITARY TOOL M22520/5-01, WITH DIE SET M22520/5-29, CAVITY A OR EQUIVALENT
- CENTER CONTACT CRIMP: USE MILITARY TOOL M22520/5-01, WITH DIE SET M22520/5-29, CAVITY B OR EQUIVALENT

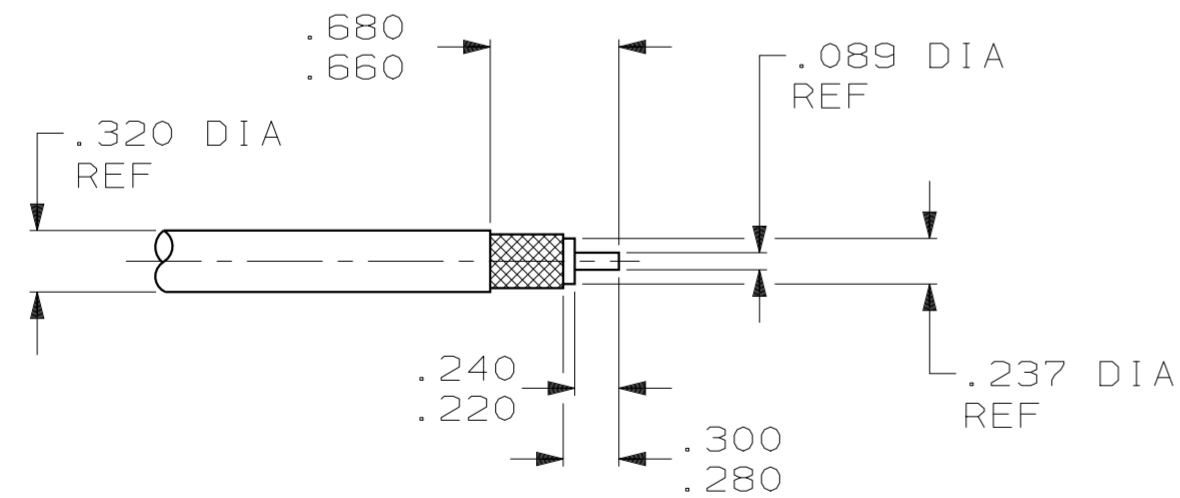
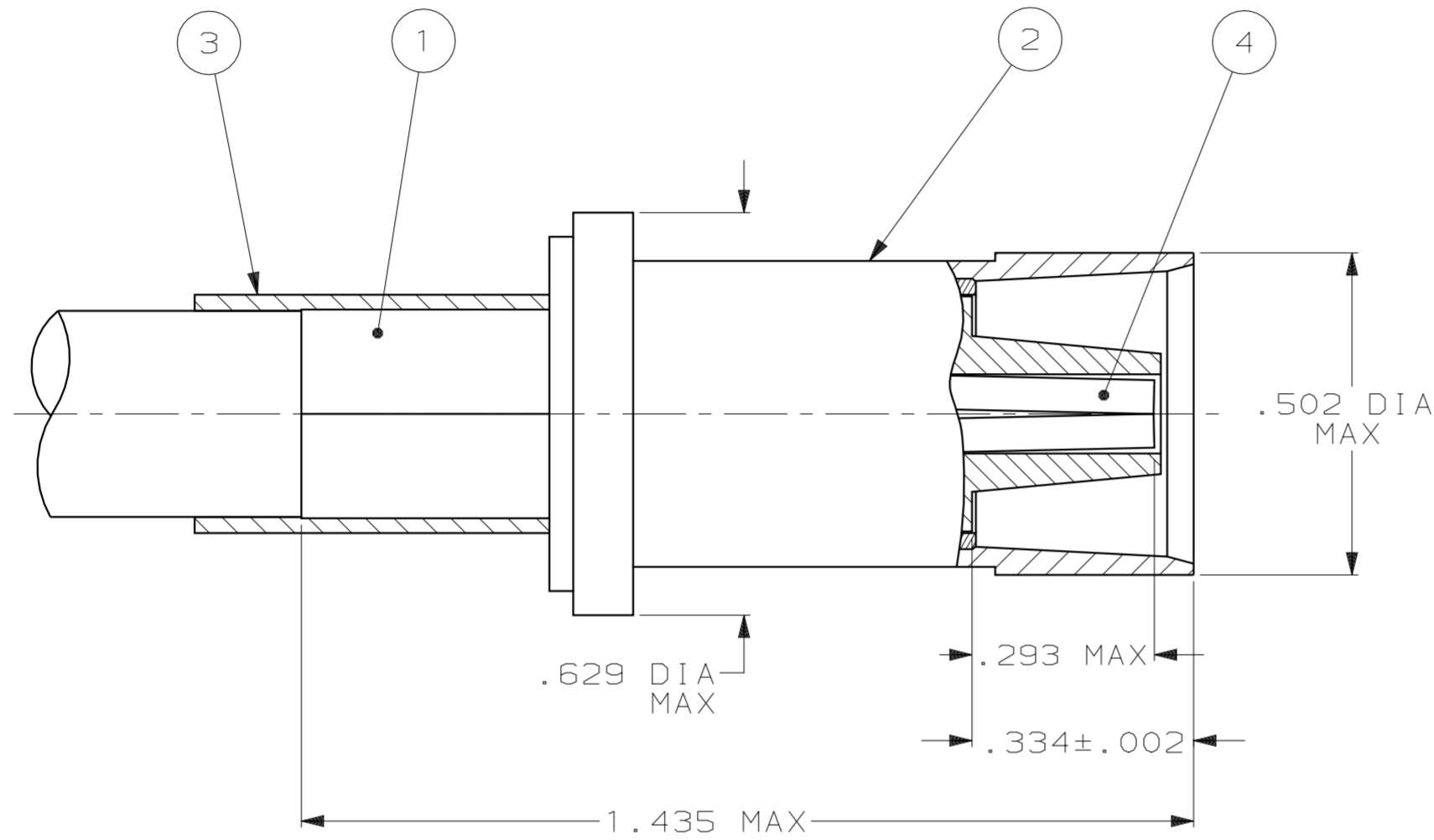

RECOMMENDED STRIP LENGTH
SCALE 1:1

QTY	PART NO	DESCRIPTION	ITEM NO
1	447091-3	CONTACT, FEMALE	4
1	228143-3	HEAT SHRINK TUBING	3
1	447088-1	SOCKET ASSEMBLY	2
1	1-446556-2	FERRULE	1

DO NOT SCALE PRINT. UNLESS SPECIFIED DIMENSIONS IN INCHES TOLERANCES ON:		DR 8/30/89		AMP INCORPORATED Harrisburg, Pa. 17105	
2 PLC DEC ± -		CHK 8/30/89			
3 PLC DEC ± .005		APPD 8/30/89		NAME COAXIAL CONTACT, SIZE 1, SOCKET	
ANGLES ± -		APPD *			
MATERIAL -		PRODUCT SPEC -		SIZE C 00779 FSCM NO 00779 DRAWING NO 447087-5	
FINISH -		APPLICATION SPEC -			
		WEIGHT -		SCALE 4:1 SHEET 1 OF 1	