

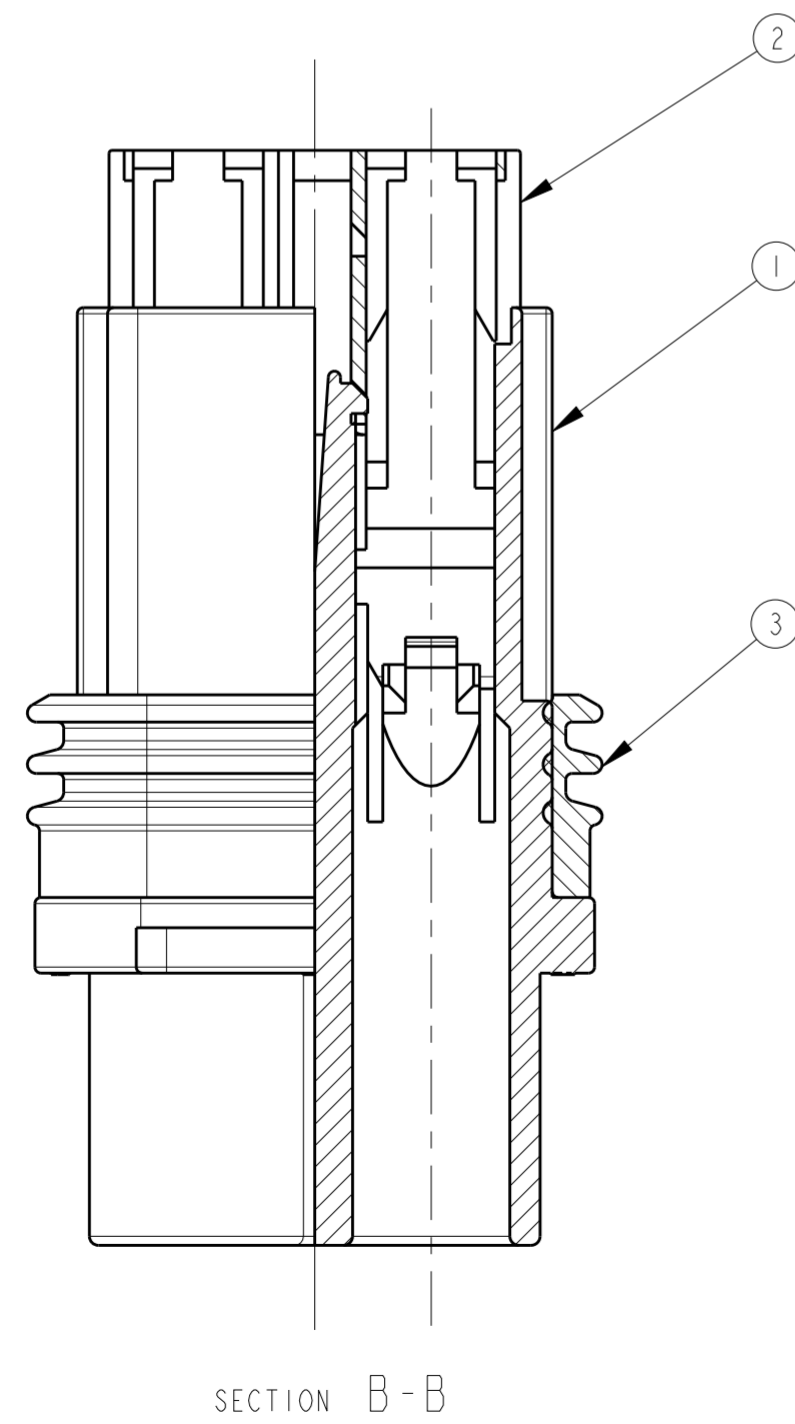

REVISIONS				
P	LTR	DESCRIPTION	DATE	APVD
D		REVISED DRAWING ECO-14-015163	08OCT2014	NCL GB

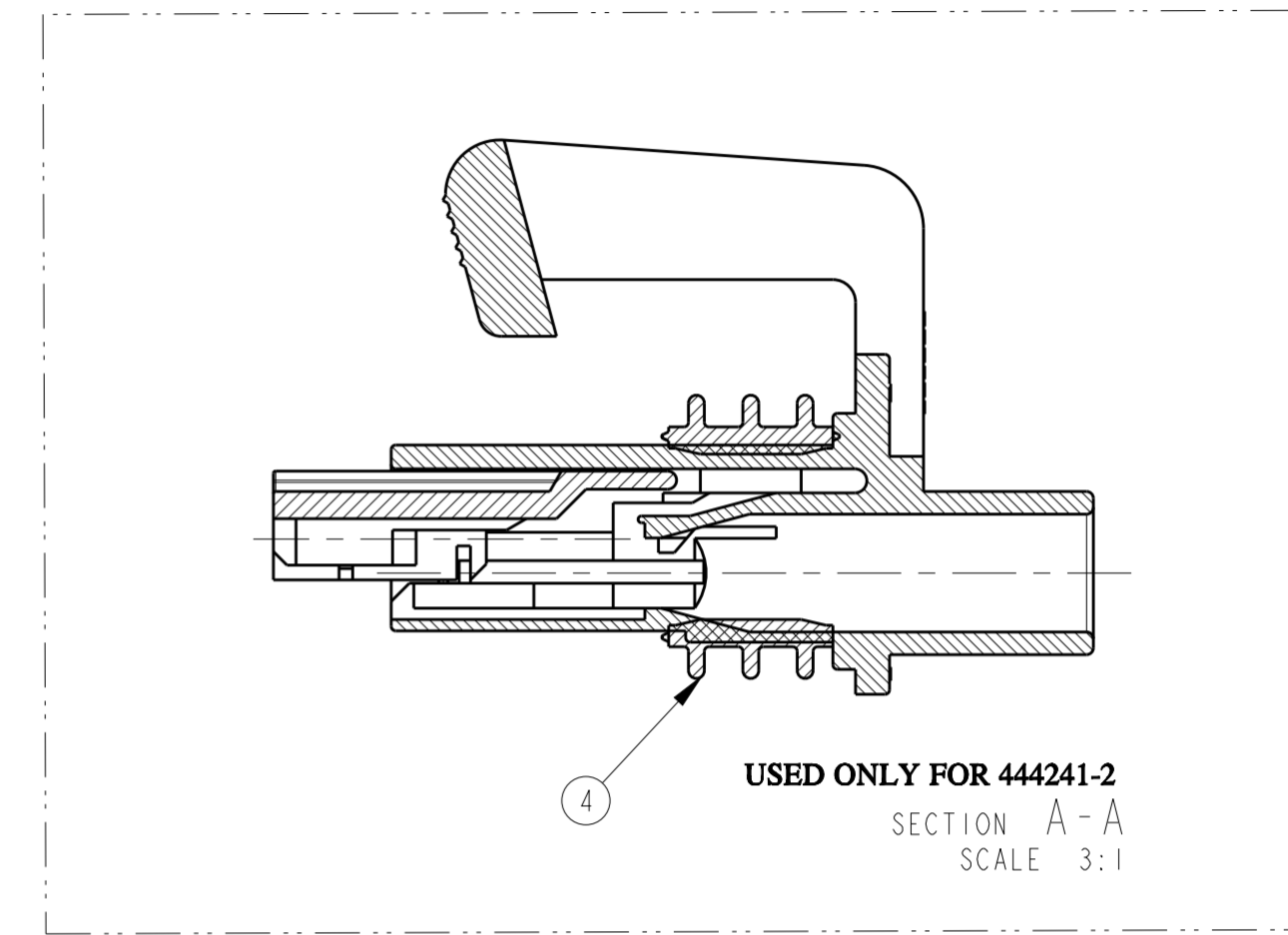
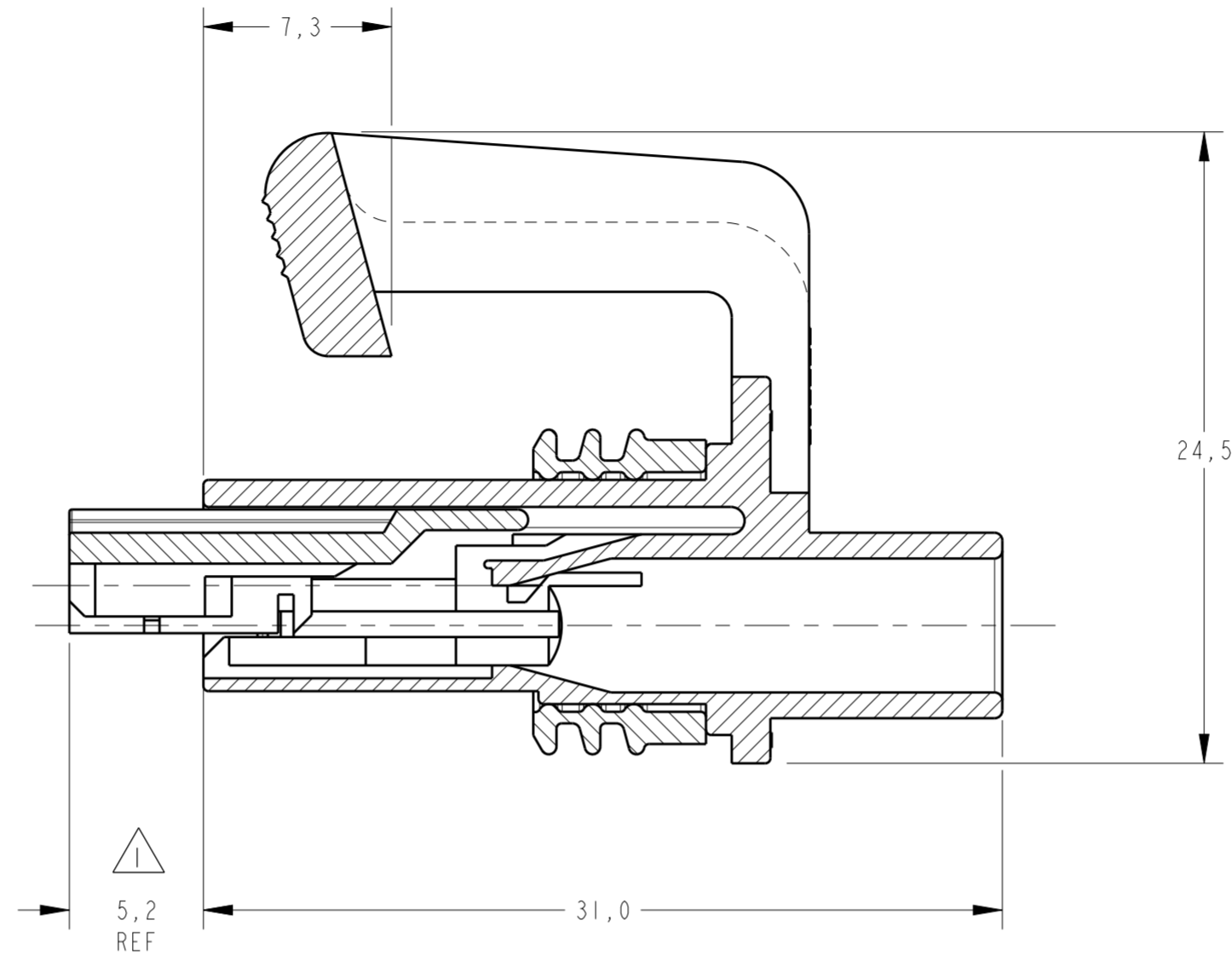
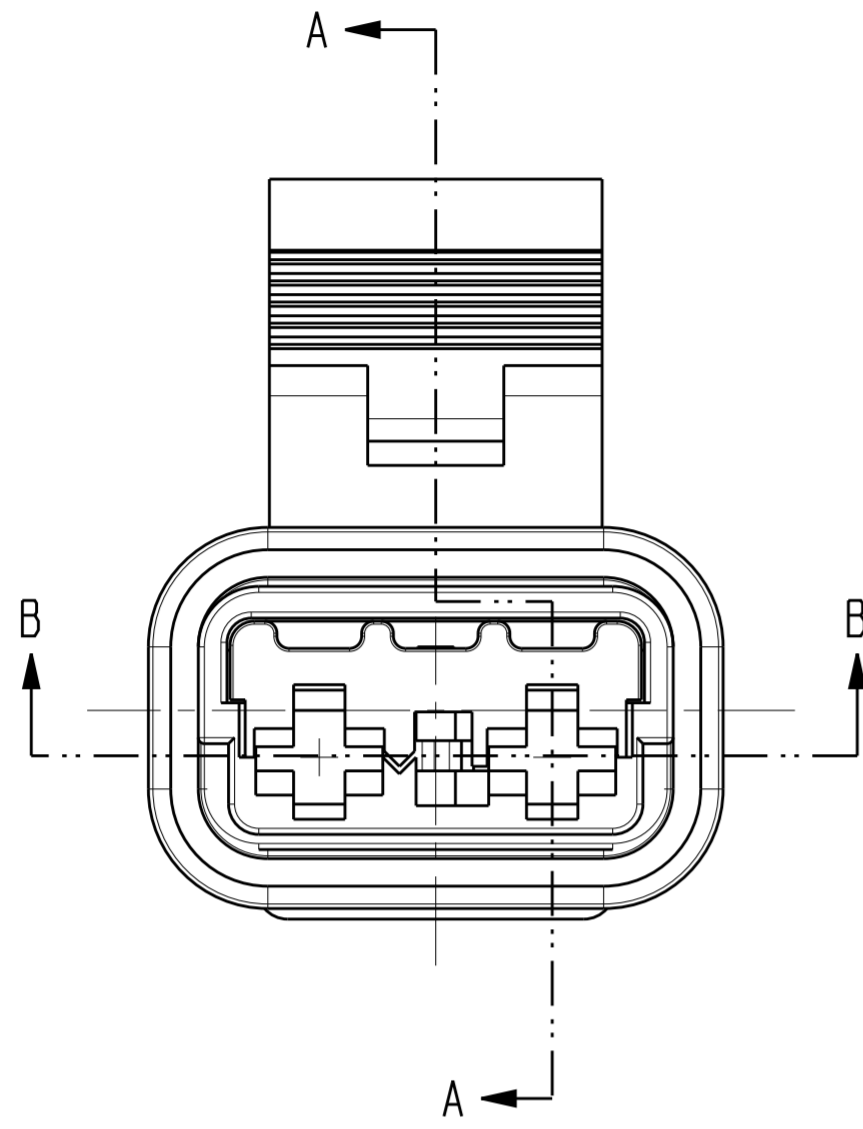

USED ONLY FOR 444241-1
SECTION A-A

GRAVAÇÕES MARKINGS
LOGOTIPO AMP AMP LOGO
CÓDIGO PAÍS PRODUTOR MANUFACTURER COUNTRY CODE
NÚMERO COMPONENTE COMPONENT NUMBER
NÚMERO CAVIDADE CAVITY NUMBER
IDENTIFICAÇÃO CIRCUITO CIRCUIT IDENTIFICATION
PAÍS PRODUTOR MANUFACTURER COUNTRY
REV+ LETRA REV.DA PEÇA REV.+ PART REV.LETTER

1 - DEVE SER FORNECIDO NA CONDIÇÃO DE PRÉ TRAVAMENTO, CONFORME MOSTRADO.

2 - PARA TERMINAIS E SELOS UTILIZADOS VEJA DESENHO DO GRUPO DE PRODUTOS: C1355046.

3 - CONTRA PEÇA: PN 444245.

1 - MUST BE SUPPLIED IN PRE LOCK POSITION, AS SHOWN.

2 - FOR CONTACTS AND SEALS SEE PRODUCT GROUP DRAWING: C1355046.

3 - COUNTER PART PN: 444245.

REQ. PER ASSY	ITEM	DESCRIPTION	MATERIAL	FINISH
1	4	SEAL, 2POSN., JPT	SILICONE	BRANCO / WHITE
- 1	3	SEAL, 2POSN., JPT	SILICONE	AZUL / BLUE
1 1	2	SPACER, 2POSN., JPT REC.	PA 6.6	AMARELO / YELLOW
1 1	1	HOUSING 2POSN., JPT REC.	PA 6.6	PRETO / BLACK

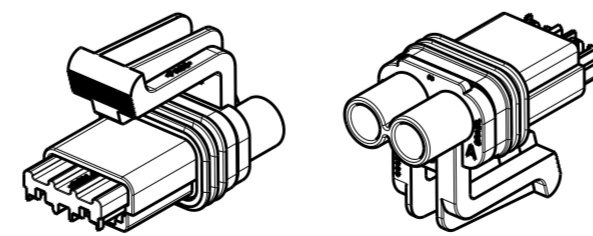

PERSPECTIVE VIEWS
SCALE 1:1

THIS DRAWING IS A CONTROLLED DOCUMENT.		DWN A. PERUSSI 20 JUN 05	TE Connectivity			
DIMENSIONS: mm		CHK P. L. FARIA 20 JUN 05				
TOLERANCES UNLESS OTHERWISE SPECIFIED:		APVD J. W. PRADO 20 JUN 05				
0 PLC ± 1 PLC ±0,3 2 PLC ± 3 PLC ± 4 PLC ± ANGLES ±° FINISH SEE TABLE		NAME HOUSING ASS'Y., 2POSN. JUNIOR POWER TIMER	SIZE A2	CAGE CODE -	DRAWING NO C-444241	RESTRICTED TO -
MATERIAL SEE TABLE		WEIGHT - / -	SCALE 4:1	SHEET 1	OF 1	REV D